











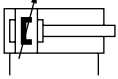

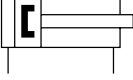
Piston rod cylinders ▶ Standard cylinders

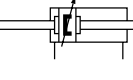
ISO 15552, series PRA

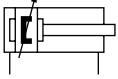
Brochure

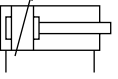

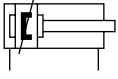
Piston rod cylinders ▶ Standard cylinders ISO 15552, series PRA



		Profile cylinder ISO 15552, Series PRA ▶ Ports: G 1/8 - G 1/2 ▶ double-acting ▶ with magnetic piston ▶ Cushioning: pneumatically, adjustable ▶ Piston rod: external thread ▶ ATEX optional	9
		Profile cylinder ISO 15552, Series PRA ▶ Ports: G 1/8 - G 1/2 ▶ double-acting ▶ with magnetic piston ▶ Cushioning: elastic ▶ Piston rod: external thread	13
		Profile cylinder ISO 15552, Series PRA ▶ Ports: G 1/8 - G 1/2 ▶ double-acting ▶ with magnetic piston ▶ Cushioning: pneumatically, adjustable ▶ Piston rod: external thread, through	16
		Profile cylinder ISO 15552, Series PRA ▶ Ports: G 1/8 - G 1/2 ▶ double-acting ▶ with magnetic piston ▶ Cushioning: pneumatically, adjustable ▶ Piston rod: external thread ▶ silicone-free ▶ heat resistant	20
		Profile cylinder ISO 15552, Series PRA ▶ Ports: G 1/8 - G 1/2 ▶ double-acting ▶ Cushioning: pneumatically, adjustable ▶ Piston rod: external thread ▶ silicone-free ▶ heat resistant	24
		Profile cylinder ISO 15552, Series PRA ▶ Low friction ▶ double-acting ▶ with magnetic piston ▶ Cushioning: pneumatically, adjustable ▶ Piston rod: external thread	28
		Profile cylinder ISO 15552, Series PRA-MS ▶ Modular sealing system	31

Accessories

Accessories overview

	Accessories overview	33
--	----------------------	----

Cylinder with distance measuring sensor











	Profile cylinder ISO 15552, Series PRA with SM6	on line
	Profile cylinder ISO 15552, Series PRA with SM6-AL	on line

Piston rod cylinders ▶ Standard cylinders
ISO 15552, series PRA

Cylinder mountings

	Bearing block, Series AB7 ▶ Cylinder mounting in accordance with ISO 15552	35
	Bearing block, Series CS7 ▶ Cylinder mounting in accordance with VDMA 24562 part 2	36
	Clevis mounting, Series AB6 ▶ Cylinder mounting in accordance with ISO 15552	37
	Clevis mounting, Series MP2 ▶ Cylinder mounting in accordance with ISO 15552	37
	Rear eye, Series MP4 ▶ Cylinder mounting in accordance with ISO 15552 ▶ for clevis mounting MP2 and AB3	38
	Rear eye, Series MP6 ▶ Cylinder mounting in accordance with ISO 15552 ▶ With ball joint and foot	39
	Rear eye, Series MP9 ▶ With rubber bushing	40
	Center trunnion mounting, Series MT4 ▶ for Series PRA	41
	Trunnion mounting, front or rear, Series MT5, MT6	42
	Bearing brackets MT4, MT5, MT6, Series AT4 ▶ Cylinder mounting in accordance with ISO 15552 ▶ for Series CCI, CCL-IC, ICL, KPZ, PRA/TRB	43

Piston rod cylinders ▶ Standard cylinders
ISO 15552, series PRA

	Eye brackets	44
	Flange mounting, Series MF1, MF2 ▶ Cylinder mounting in accordance with ISO 15552	45
	Intermediate flange, Series JP1 ▶ for multi-position cylinders	46
	Foot mounting, Series MS1	46
	Bolts, AA4	48
Piston rod mountings		
	Nut for piston rod, Series MR9	49
	Rod clevis, Series AP2 ▶ galvanized steel	49
	Rod clevis, Series PM6 ▶ galvanized steel	50
	Ball eye rod end with flange, Series AP6 ▶ galvanized steel	51
	Flexible spherical coupling, Series PM5	51
	Flexible plate coupling, Series PM7	52

Piston rod cylinders ▶ Standard cylinders
ISO 1552, series PRA

Modular sealing system



Series MSS
 ▶ Für Serie: PRA, TRB (Ø 32 - 125 mm)

53

Guide units



Guide unit, Series GU1

56



Guide unit, Series GH2

58



Guide unit, Series GH1

63



Flange mounting

67



Flexible coupling form B, Series GU3

68



Flexible coupling form C, Series GU3

68

Locking units



Holding unit, Series HU1
 ▶ Ø32 - 100 mm ▶ hold: spring force, release: compressed air











70













Locking unit, Series LU1
 ▶ Ø32 - 100 mm ▶ Hold: adjustable spring force, Release: compressed air

72

Piston rod cylinders ▶ Standard cylinders
ISO 1552, series PRA





	Locking unit, Series LU1 ▶ Ø32 - 100 mm ▶ hold: spring force, release: compressed air	74
	Locking unit, Series LU6 ▶ Ø32 - 125 mm ▶ Holding and braking: non-adjustable spring, Release: compressed air	76
	Foot mounting, Series LU4 ▶ for cylinders with locking units	80
	Flange mounting, Series LU5 ▶ for cylinders with locking units	82
	Mounting flange, Series LU3 ▶ for cylinders with locking units	83
Sensors and sensor mountings, accessories		
	Sensor, Series ST6 ▶ 6 mm T-slot ▶ with cable ▶ open cable ends, 2-pin, open cable ends, 3-pin	85
	Sensor, Series ST6 ▶ 6 mm T-slot ▶ with cable ▶ open cable ends, 3-pin ▶ ATEX certified	87
	Sensor, Series ST6 ▶ 6 mm T-slot ▶ with cable ▶ Plug, M8, 3-pin, with knurled screw	88
	Sensor, Series ST6 ▶ 6 mm T-slot ▶ with cable ▶ Plug, M8, 3-pin, with knurled screw ▶ ATEX certified	90
	Sensor, Series ST6 ▶ 6 mm T-slot ▶ with cable ▶ Plug, M8, 3-pin	91

Piston rod cylinders ▶ Standard cylinders
ISO 15552, series PRA

	Sensor, Series ST6 ▶ 6 mm T-slot ▶ with cable ▶ Plug, M12, 3-pin, with knurled screw	93
	Sensor, Series ST6 ▶ 6 mm T-slot ▶ with cable ▶ Plug, M12, 3-pin, with knurled screw ▶ ATEX certified	94
	Sensor, Series ST6-HT ▶ 6 mm T-slot ▶ with cable ▶ open cable ends, 2-pin ▶ heat resistant	96
	Sensors, Series SM6 ▶ 6 mm groove ▶ with cable ▶ without wire end ferrule, tin-plated, 4-pin ▶ with distance measuring sensor, measurement range 32 - 256 mm	97
	Sensors, Series SM6 ▶ 6 mm groove ▶ with cable ▶ Plug, M8x1, 4-pin, with knurled screw ▶ with distance measuring sensor, measurement range 32 - 256 mm	98
	Sensors, Series SM6-AL ▶ with cable ▶ Plug, M8x1, 4-pin ▶ with distance measuring sensor, measurement range 107 - 1007 mm ▶ IO-Link	100
	Sensor, Series SN3 ▶ Plug, M12, 3-pin ▶ welding-proof	102
	Sensor, Series IN1 ▶ for locking unit, series LU6	104
	Sensor mounting, Series CB1 ▶ for Series SN1, SN2 ▶ to mount on cylinder PRA	105
	Sensor mounting, Series CB1 ▶ for Series ST6, SM6 ▶ to mount on cylinder TRB, C12P, 167, CVI, TRR, 523	105
	Sensor mounting, Series CB1 ▶ for Series SN3 ▶ to mount on cylinder PRA, KPZ, GPC, CCI, KHZ	106
	Connecting cable, Series CN2 ▶ Socket, M8, 3-pin, straight ▶ open cable ends, 3-pin	106
	Connecting cable, Series CN2 ▶ Socket, M8x1, 3-pin, angled ▶ open cable ends, 3-pin	107

Piston rod cylinders ▶ Standard cylinders

ISO 15552, series PRA

	<p>Connecting cable, Series CN2</p> <ul style="list-style-type: none"> ▶ Socket, M12x1, 5-pin, A-coded, angled ▶ without wire end ferrule, tin-plated, 4-pin ▶ for CANopen, DeviceNet 	109
	<p>Socket, M8x1, Series CN2</p> <ul style="list-style-type: none"> ▶ Socket, M8x1, 3-pin 	110
	<p>Socket, M8x1, Series CN2</p> <ul style="list-style-type: none"> ▶ Socket, M8x1, 3-pin, angled 	111
Other accessories		
	<p>Silencers, Series SI1</p> <ul style="list-style-type: none"> ▶ Sintered bronze 	113
	<p>Silencers, Series SI1</p> <ul style="list-style-type: none"> ▶ Sintered bronze 	114

Piston rod cylinders ▶ Standard cylinders

Profile cylinder ISO 15552, Series PRA

▶ Ports: G 1/8 - G 1/2 ▶ double-acting ▶ with magnetic piston ▶ Cushioning: pneumatically, adjustable ▶ Piston rod: external thread ▶ ATEX optional

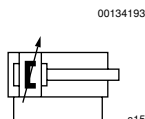

Standards	ISO 15552
Compressed air connection	Internal thread
Working pressure min./max.	2 bar / 10 bar
Ambient temperature min./max.	-20 °C / +80 °C
Medium temperature min./max.	-20 °C / +80 °C
Medium	Compressed air
Max. particle size	50 μm
Oil content of compressed air	0 mg/m ³ - 5 mg/m ³
Pressure for determining piston forces	6,3 bar

Materials:	
Cylinder tube	Aluminum, anodized
Piston rod	Stainless steel
Front cover	Die-cast aluminum
End cover	Die-cast aluminum
Seal	Polyurethane
Nut for piston rod	Steel, galvanized
Scraper	Polyurethane

Technical Remarks

- The pressure dew point must be at least 15 °C under ambient and medium temperature and may not exceed 3 °C.
- The oil content of compressed air must remain constant during the life cycle.
- Use only the approved oils from AVENTICS, see chapter „Technical information“.
- ATEX-certified cylinders can be generated in the Internet configurator.
- ATEX ID: II 2G c IIB T4 II 2D c IP65 T125 °C X
- The operating temperature range for ATEX-certified cylinders is -20 °C ... 50 °C.

Piston Ø	[mm]	32	40	50	63	80
Retracting piston force	[N]	435	660	1035	1765	2855
Extracting piston force	[N]	505	790	1235	1960	3165
Cushioning length	[mm]	16.5	19	17	16.5	19.5
Cushioning energy	[J]	4.8	9	15	27	54
Weight	0 mm stroke	0.5	0.65	1.06	1.42	2.37
	+10 mm stroke	0.022	0.032	0.047	0.054	0.085
Stroke max.	[mm]	1600	1900	2100	2500	2800
Working pressure min./max.	[bar]	1.5 - 10	1.5 - 10	1.5 - 10	1.5 - 10	1.5 - 10

Piston Ø	[mm]	100	125			
Retracting piston force	[N]	4635	7220			
Extracting piston force	[N]	4945	7725			
Cushioning length	[mm]	19.5	22			
Cushioning energy	[J]	88	140			
Weight	0 mm stroke	3.51	6.72			
	+10 mm stroke	0.1	0.15			
Stroke max.	[mm]	2800	2750			
Working pressure min./max.	[bar]	1.5 - 10	1.5 - 10			

Piston rod cylinders ▶ Standard cylinders
Profile cylinder ISO 15552, Series PRA

▶ Ports: G 1/8 - G 1/2 ▶ double-acting ▶ with magnetic piston ▶ Cushioning: pneumatically, adjustable ▶ Piston rod: external thread ▶ ATEX optional

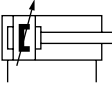
	Piston Ø Piston rod thread Ports Piston rod Ø	32	40	50	63	80	
		M10x1,25 G 1/8 12	M12x1,25 G 1/4 16	M16x1,5 G 1/4 20	M16x1,5 G 3/8 20	M20x1,5 G 3/8 25	
	Stroke 25	0822120001	0822121001	0822122001	0822123001	0822124001	
	50	0822120002	0822121002	0822122002	0822123002	0822124002	
	80	0822120003	0822121003	0822122003	0822123003	0822124003	
	100	0822120004	0822121004	0822122004	0822123004	0822124004	
	125	0822120005	0822121005	0822122005	0822123005	0822124005	
	160	0822120006	0822121006	0822122006	0822123006	0822124006	
	200	0822120007	0822121007	0822122007	0822123007	0822124007	
	250	0822120008	0822121008	0822122008	0822123008	0822124008	
	320	0822120009	0822121009	0822122009	0822123009	0822124009	
	400	0822120010	0822121010	0822122010	0822123010	0822124010	
	500	0822120011	0822121011	0822122011	0822123011	0822124011	
		Piston Ø Piston rod thread Ports Piston rod Ø	100 M20x1,5 G 1/2 25	125 M27x2 G 1/2 32			
	Stroke 25	0822125001	R480140491				
	50	0822125002	R480140455				
	80	0822125003	R480141371				
	100	0822125004	R480079499				
	125	0822125005	R480140083				
	160	0822125006	R480079809				
	200	0822125007	R480140833				
	250	0822125008	R480141106				
320	0822125009	R480140759					
400	0822125010	R480141373					
500	0822125011	R480141666					

Configurable product



This product is configurable. Please use our Internet configurator at <http://www.aventics.com> or contact the nearest AVENTICS sales office.

Piston rod cylinders ▶ Standard cylinders

Profile cylinder ISO 15552, Series PRA

▶ Ports: G 1/8 - G 1/2 ▶ double-acting ▶ with magnetic piston ▶ Cushioning: pneumatically, adjustable ▶ Piston rod: external thread ▶ ATEX optional

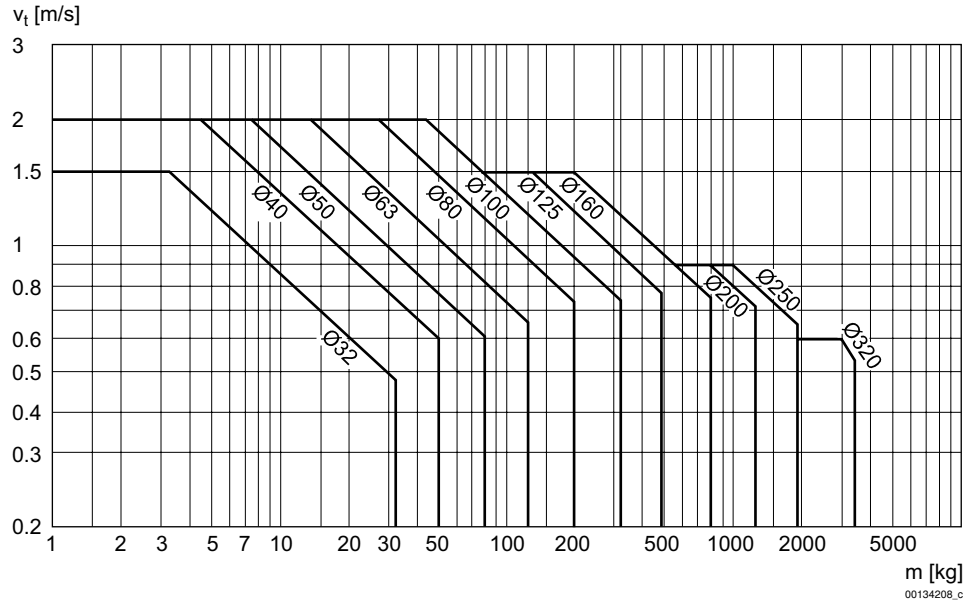
Cushioning diagram



v = Piston velocity [m/s]
m = Cushionable mass [kg]

Dimensions

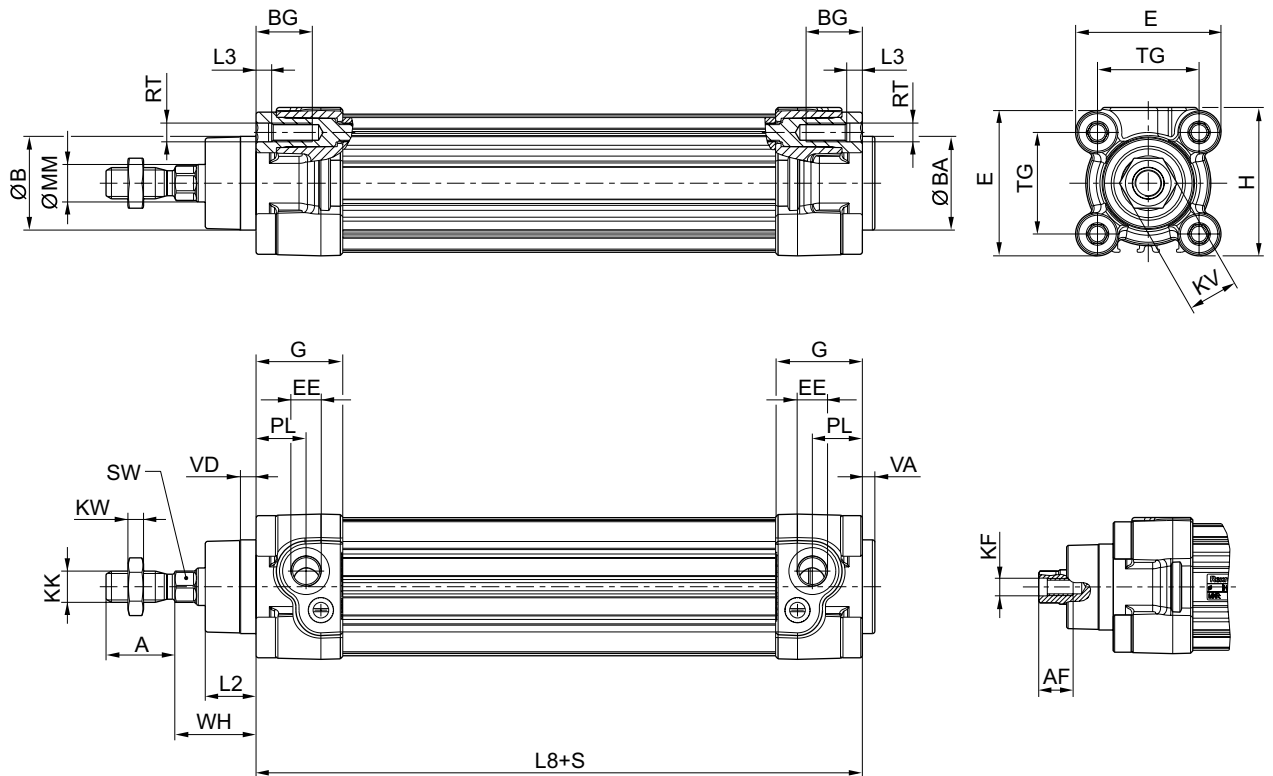

S = stroke

00134208_a

Piston rod cylinders ▶ Standard cylinders
Profile cylinder ISO 15552, Series PRA

▶ Ports: G 1/8 - G 1/2 ▶ double-acting ▶ with magnetic piston ▶ Cushioning: pneumatically, adjustable ▶ Piston rod: external thread ▶ ATEX optional

Piston Ø	A -2	AF+1	ØB d11	ØBA d11	BG min.	E	EE	G	H	KF	KK
32	22	12	30	30	16	46.5	G 1/8	27.75	47.5	M6	M10x1,25
40	24	13.5	35	35	16	53	G 1/4	33.25	53	M8	M12x1,25
50	32	17	40	40	16	65	G 1/4	31	65	M10	M16x1,5
63	32	17	45	45	16	75	G 3/8	38.25	75	M10	M16x1,5
80	40	21	45	45	17	95	G 3/8	38.25	95	M12	M20x1,5
100	40	21	55	55	17	115	G 1/2	42.25	115	M12	M20x1,5
125	54	28	60	60	20	140	G 1/2	53.85	140	M16	M27x2

Piston Ø	KV	KW	ØMM f8	PL	L2	L3 ±0,5	L8	RT	SW	TG	VA -1	VD
32	16	5	12	16	16.25	4.5	94±0,4	M6	10	32,5±0,5	4	5
40	18	6	16	20	18.25	4.5	105±0,7	M6	13	38±0,5	4	5
50	24	8	20	19	25	4.5	106±0,7	M8	17	46,5±0,6	4	5
63	24	8	20	24	25	4.5	121±0,8	M8	17	56,5±0,7	4	5
80	30	10	25	23.5	33	0	128±0,8	M10	22	72±0,7	4	5
100	30	10	25	25	36	0	138±1	M10	22	89±0,7	4	5
125	41	13.5	32	33	45	0	160±1	M12	27	110±1,1	6	7

Piston Ø	WH											
32	26±1,4											
40	30±1,4											
50	37±1,4											
63	37±1,8											
80	46±1,8											
100	51±1,8											
125	65±2,2											

Piston rod cylinders ▶ Standard cylinders

Profile cylinder ISO 15552, Series PRA

▶ Ports: G 1/8 - G 1/2 ▶ double-acting ▶ with magnetic piston ▶ Cushioning: elastic ▶ Piston rod: external thread

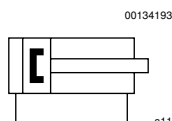

Standards	ISO 15552
Compressed air connection	Internal thread
Working pressure min./max.	2 bar / 10 bar
Ambient temperature min./max.	-20 °C / +80 °C
Medium temperature min./max.	-20 °C / +80 °C
Medium	Compressed air
Max. particle size	50 μm
Oil content of compressed air	0 mg/m ³ - 5 mg/m ³
Pressure for determining piston forces	6,3 bar

Materials:	
Cylinder tube	Aluminum, anodized
Piston rod	Stainless steel
Front cover	Die-cast aluminum
End cover	Die-cast aluminum
Seal	Polyurethane
Nut for piston rod	Steel, galvanized
Scraper	Polyurethane

Technical Remarks

- The pressure dew point must be at least 15 °C under ambient and medium temperature and may not exceed 3 °C.
- The oil content of compressed air must remain constant during the life cycle.
- Use only the approved oils from AVENTICS, see chapter „Technical information“.

Piston Ø	[mm]	32	40	50	63	80	
Retracting piston force	[N]	435	660	1035	1765	2855	
Extracting piston force	[N]	505	790	1235	1960	3165	
Impact energy	[J]	0.4	0.65	1	1.6	2.5	
Weight	0 mm stroke	[kg]	0.5	0.65	1.06	1.42	2.37
	+10 mm stroke	[kg]	0.022	0.032	0.047	0.054	0.085
Stroke max.	[mm]	1600	1900	2100	2500	2800	
Working pressure min./max.	[bar]	1.5 - 10	1.5 - 10	1.5 - 10	1.5 - 10	1.5 - 10	

Piston Ø	[mm]	100	125			
Retracting piston force	[N]	4635	7220			
Extracting piston force	[N]	4945	7725			
Impact energy	[J]	3.9	6			
Weight	0 mm stroke	[kg]	3.51	6.72		
	+10 mm stroke	[kg]	0.1	0.15		
Stroke max.	[mm]	2800	2750			
Working pressure min./max.	[bar]	1.5 - 10	1.5 - 10			

Piston rod cylinders ▶ Standard cylinders
Profile cylinder ISO 15552, Series PRA
▶ Ports: G 1/8 - G 1/2 ▶ double-acting ▶ with magnetic piston ▶ Cushioning: elastic ▶ Piston rod: external thread

	Piston Ø Piston rod thread Ports Piston rod Ø	32 M10x1,25 G 1/8 12	40 M12x1,25 G 1/4 16	50 M16x1,5 G 1/4 20	63 M16x1,5 G 3/8 20	80 M20x1,5 G 3/8 25	
	Stroke 25	R480041555	R480041559	R480041563	R480041567	R480041573	
	50	R480041556	R480041560	R480041564	R480041568	R480041574	
	80	R480041557	R480041561	R480041565	R480041569	R480041575	
	100	R480041558	R480041562	R480041566	R480041570	R480041576	
	125	R480151537	R480051376	R480045537	R480054955	R480152097	
	160	R480143129	R480044478	R480156862	R480152784	R480044479	
	200	R480041250	R480151194	R480045822	R480148986	R480068280	
	250	R480162928	R480068778	R480152659	R480069183	R480163037	
	320	R480162929	R480160211	R480042163	R480148534	R480148937	
	400	R480069508	R480162989	R480153304	R480148988	R480157647	
	500	R480048725	R480044634	R480070399	R480154536	R480158439	
		Piston Ø Piston rod thread Ports Piston rod Ø	100 M20x1,5 G 1/2 25	125 M27x2 G 1/2 32			
	Stroke 25	R480041577	R480148022				
	50	R480041578	R480141034				
	80	R480041579	R480143254				
	100	R480041580	R480170767				
	125	R480150480	R480170768				
	160	R480051377	R480144243				
	200	R480163053	R480167296				
	250	R480163054	R480170769				
320	R480155887	R480170770					
400	R480163055	R480170771					
500	R480152777	R480170772					

Configurable product



This product is configurable. Please use our Internet configurator at <http://www.aventics.com> or contact the nearest AVENTICS sales office.

Piston rod cylinders ▶ Standard cylinders

Profile cylinder ISO 15552, Series PRA

▶ Ports: G 1/8 - G 1/2 ▶ double-acting ▶ with magnetic piston ▶ Cushioning: elastic ▶ Piston rod: external thread

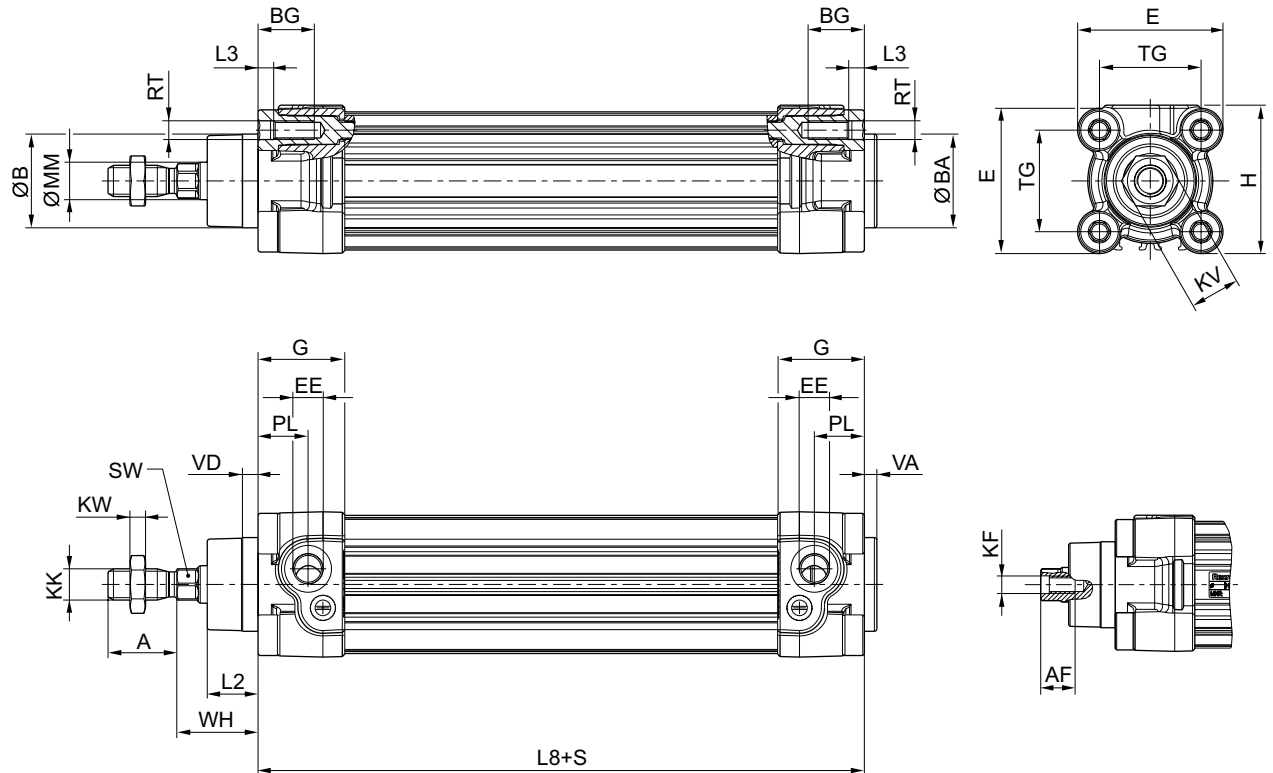
Dimensions



00134208_a

S = stroke

Piston Ø	A -2	AF+1	ØB d11	ØBA d11	BG min.	E	EE	G	H	KF	KK
32	22	12	30	30	16	46.5	G 1/8	27.75	47.5	M6	M10x1,25
40	24	13.5	35	35	16	53	G 1/4	33.25	53	M8	M12x1,25
50	32	17	40	40	16	65	G 1/4	31	65	M10	M16x1,5
63	32	17	45	45	16	75	G 3/8	38.25	75	M10	M16x1,5
80	40	21	45	45	17	95	G 3/8	38.25	95	M12	M20x1,5
100	40	21	55	55	17	115	G 1/2	42.25	115	M12	M20x1,5
125	54	28	60	60	20	140	G 1/2	53.85	140	M16	M27x2

Piston Ø	KV	KW	ØMM f8	PL	L2	L3 ±0,5	L8	RT	SW	TG	VA -1	VD
32	16	5	12	16	16.25	4.5	94±0,4	M6	10	32,5±0,5	4	5
40	18	6	16	20	18.25	4.5	105±0,7	M6	13	38±0,5	4	5
50	24	8	20	19	25	4.5	106±0,7	M8	17	46,5±0,6	4	5
63	24	8	20	24	25	4.5	121±0,8	M8	17	56,5±0,7	4	5
80	30	10	25	23.5	33	0	128±0,8	M10	22	72±0,7	4	5
100	30	10	25	25	36	0	138±1	M10	22	89±0,7	4	5
125	41	13.5	32	33	45	0	160±1	M12	27	110±1,1	6	7

Piston Ø	WH											
32	26±1,4											
40	30±1,4											
50	37±1,4											
63	37±1,8											
80	46±1,8											
100	51±1,8											
125	65±2,2											

Part numbers marked in bold are available from the central warehouse in Germany, see the shopping basket for more detailed information

Pneumatics catalog, online PDF, as of 2017-05-02, ©AVENTICS S.à r.l., subject to change

Piston rod cylinders ▶ Standard cylinders

Profile cylinder ISO 15552, Series PRA

▶ Ports: G 1/8 - G 1/2 ▶ double-acting ▶ with magnetic piston ▶ Cushioning: pneumatically, adjustable ▶ Piston rod: external thread, through

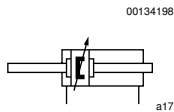

Standards	ISO 15552
Compressed air connection	Internal thread
Working pressure min./max.	2 bar / 10 bar
Ambient temperature min./max.	-20 °C / +80 °C
Medium temperature min./max.	-20 °C / +80 °C
Medium	Compressed air
Max. particle size	50 µm
Oil content of compressed air	0 mg/m ³ - 5 mg/m ³
Pressure for determining piston forces	6,3 bar

Materials:	
Cylinder tube	Aluminum, anodized
Piston rod	Stainless steel
Front cover	Die-cast aluminum
End cover	Die-cast aluminum
Seal	Polyurethane
Nut for piston rod	Steel, galvanized
Scraper	Polyurethane

Technical Remarks

- The pressure dew point must be at least 15 °C under ambient and medium temperature and may not exceed 3 °C.
- The oil content of compressed air must remain constant during the life cycle.
- Use only the approved oils from AVENTICS, see chapter „Technical information“.

Piston Ø	[mm]	32	40	50	63	80	
Retracting piston force	[N]	435	660	1035	1765	2855	
Extracting piston force	[N]	435	660	1035	1765	2855	
Cushioning length	[mm]	16.5	19	17	16.5	19.5	
Cushioning energy	[J]	4.8	9	15	27	54	
Weight	0 mm stroke	[kg]	0.58	0.8	1.34	1.72	2.92
	+10 mm stroke	[kg]	0.031	0.048	0.072	0.079	0.124
Stroke max.	[mm]	1500	1500	1500	1500	1500	
Working pressure min./max.	[bar]	1.5 - 10	1.5 - 10	1.5 - 10	1.5 - 10	1.5 - 10	

Piston Ø	[mm]	100	125			
Retracting piston force	[N]	4635	7220			
Extracting piston force	[N]	4635	7220			
Cushioning length	[mm]	19.5	22			
Cushioning energy	[J]	88	140			
Weight	0 mm stroke	[kg]	4.08	8.92		
	+10 mm stroke	[kg]	0.139	0.22		
Stroke max.	[mm]	1500	1500			
Working pressure min./max.	[bar]	1.5 - 10	1.5 - 10			

Piston rod cylinders ▶ Standard cylinders

Profile cylinder ISO 15552, Series PRA

▶ Ports: G 1/8 - G 1/2 ▶ double-acting ▶ with magnetic piston ▶ Cushioning: pneumatically, adjustable ▶ Piston rod: external thread, through

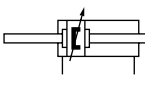
	Piston Ø Piston rod thread Ports Piston rod Ø	32	40	50	63	80	
		M10x1,25 G 1/8 12	M12x1,25 G 1/4 16	M16x1,5 G 1/4 20	M16x1,5 G 3/8 20	M20x1,5 G 3/8 25	
	Stroke 25	R480041413	R480041432	R480041443	R480041453	R480041484	
	50	R480041419	R480041433	R480041444	R480041454	R480041485	
	80	R480041420	R480041434	R480041445	R480041455	R480041487	
	100	R480041421	R480041435	R480041446	R480041456	R480041488	
	125	R480041422	R480041436	R480041074	R480041457	R480041490	
	160	R480041423	R480041437	R480041447	R480041458	R480041491	
	200	R480041425	R480041438	R480041448	R480041459	R480041492	
	250	R480041426	R480041439	R480041449	R480041460	R480041493	
	320	R480041427	R480041440	R480041450	R480041461	R480041494	
	400	R480041428	R480041441	R480041451	R480041481	-	
	500	R480041429	R480041442	R480041452	R480041482	R480041497	
		Piston Ø Piston rod thread Ports Piston rod Ø	100	125			
			M20x1,5 G 1/2 25	M27x2 G 1/2 32			
	Stroke 25		R480148059	R480148066			
	50		R480069994	R480148067			
	80		R480148061	R480148068			
	100		R480059815	R480142910			
	125		R480146278	R480148069			
	160		R480148062	R480148070			
200		R480148063	R480148071				
250		R480077546	R480148072				
320		R480148064	R480148073				
400		R480148065	R480148074				
500		R480148060	R480148075				

Configurable product



This product is configurable. Please use our Internet configurator at <http://www.aventics.com> or contact the nearest AVENTICS sales office.

Profile cylinder ISO 15552, Series PRA

▶ Ports: G 1/8 - G 1/2 ▶ double-acting ▶ with magnetic piston ▶ Cushioning: pneumatically, adjustable ▶ Piston rod: external thread, through

Cushioning diagram

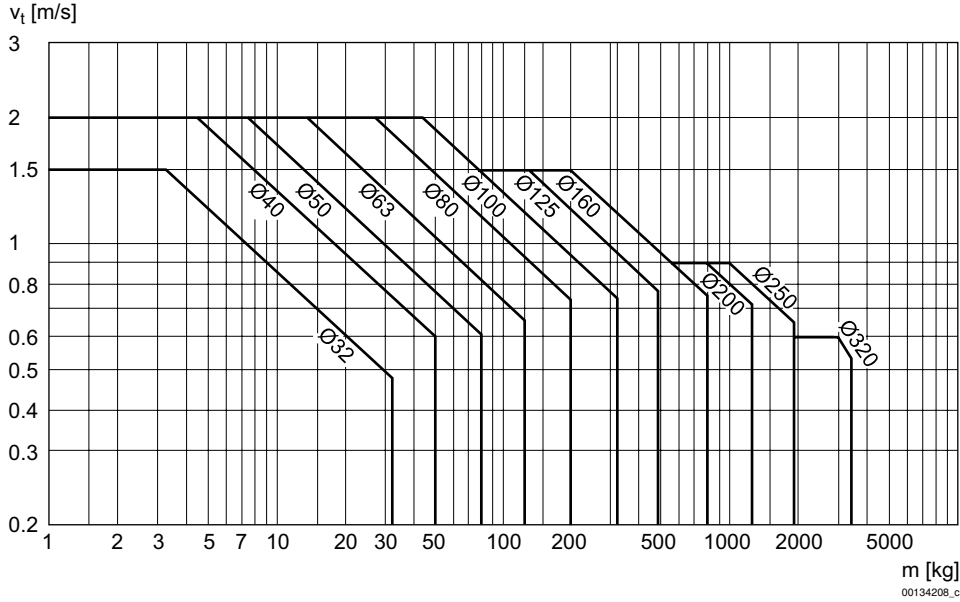

v = Piston velocity [m/s]
m = Cushionable mass [kg]

Dimensions

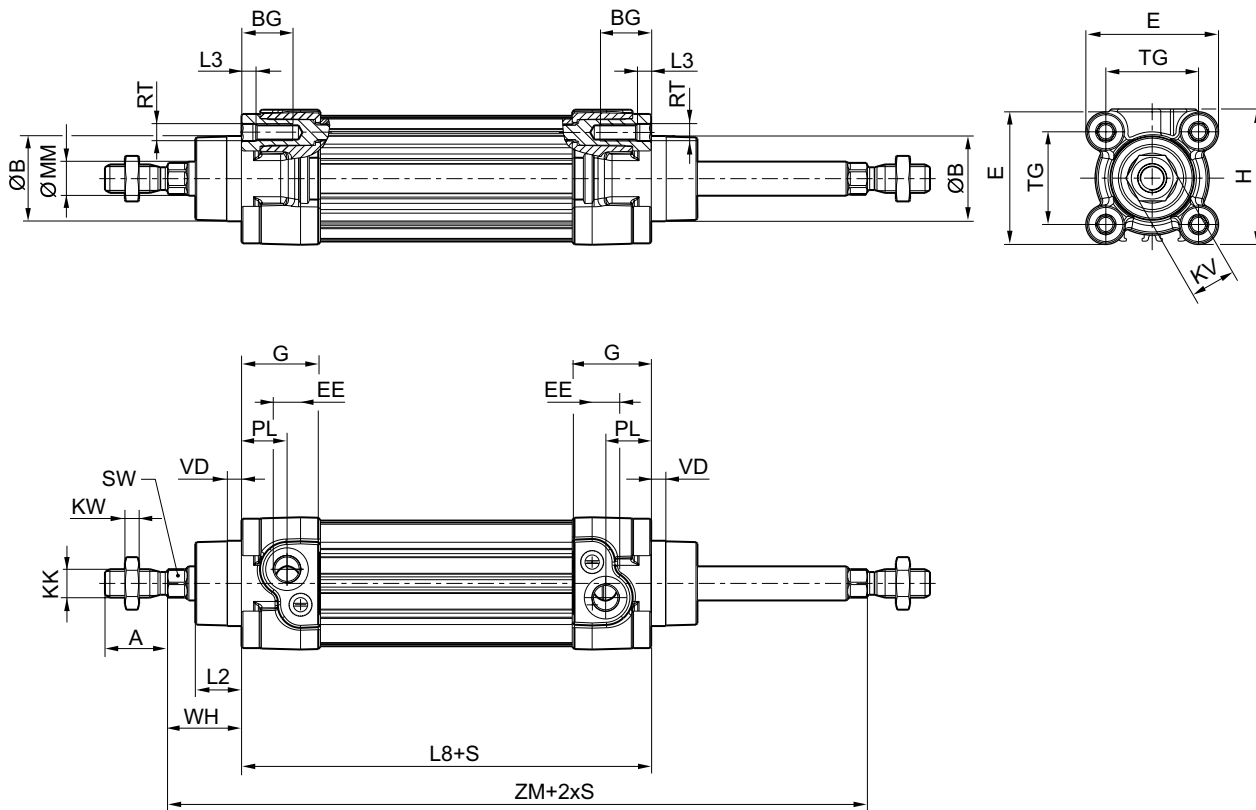

S = stroke

00134209

Piston rod cylinders ▶ Standard cylinders
Profile cylinder ISO 15552, Series PRA

▶ Ports: G 1/8 - G 1/2 ▶ double-acting ▶ with magnetic piston ▶ Cushioning: pneumatically, adjustable ▶ Piston rod: external thread, through

Piston Ø	A -2	ØB d11	BG min.	E	EE	G	H	KK	KV	KW	ØMM f8
32	22	30	16	46.5	G 1/8	27.75	47.5	M10x1,25	16	5	12
40	24	35	16	53	G 1/4	33.25	53	M12x1,25	18	6	16
50	32	40	16	65	G 1/4	31	65	M16x1,5	24	8	20
63	32	45	16	75	G 3/8	38.25	75	M16x1,5	24	8	20
80	40	45	17	95	G 3/8	38.25	95	M20x1,5	30	10	25
100	40	55	17	115	G 1/2	42.25	115	M20x1,5	30	10	25
125	54	60	20	140	G 1/2	53.85	140	M27x2	41	13.5	32

Piston Ø	PL	L2	L3 ±0,5	L8	RT	SW	TG	VD	WH	ZM
32	16	16.25	4.5	94±0,4	M6	10	32,5±0,5	5	26±1,4	146+3/-1,5
40	20	18.25	4.5	105±0,7	M6	13	38±0,5	5	30±1,4	165+3/-1,5
50	19	25	4.5	106±0,7	M8	17	46,5±0,6	5	37±1,4	180+3/-1,5
63	24	25	4.5	121±0,8	M8	17	56,5±0,7	5	37±1,8	195+3/-1,5
80	23.5	33	0	128±0,8	M10	22	72±0,7	5	46±1,8	220+3/-1,5
100	25	36	0	138±1	M10	22	89±0,7	5	51±1,8	240+3,5/-2
125	33	45	0	160±1	M12	27	110±1,1	7	65±2,2	290+3,5/-2

Profile cylinder ISO 15552, Series PRA

▶ Ports: G 1/8 - G 1/2 ▶ double-acting ▶ with magnetic piston ▶ Cushioning: pneumatically, adjustable ▶ Piston rod: external thread ▶ silicone-free ▶ heat resistant



00134193

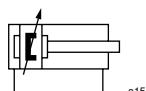

a15

Standards	ISO 15552
Compressed air connection	Internal thread
Working pressure min./max.	2 bar / 10 bar
Ambient temperature min./max.	-10°C / +120°C
Medium temperature min./max.	-10°C / +120°C
Medium	Compressed air
Max. particle size	50 µm
Oil content of compressed air	0 mg/m ³ - 5 mg/m ³
Pressure for determining piston forces	6,3 bar

Materials:	
Cylinder tube	Aluminum, anodized
Piston rod	Stainless steel
Front cover	Die-cast aluminum
End cover	Die-cast aluminum
Seal	Fluorocautchouc
Nut for piston rod	Steel, galvanized
Scraper	Fluorocautchouc

Technical Remarks

- The pressure dew point must be at least 15 °C under ambient and medium temperature and may not exceed 3 °C.
- The oil content of compressed air must remain constant during the life cycle.
- Use only the approved oils from AVENTICS, see chapter „Technical information“.

Piston Ø	[mm]	32	40	50	63	80	
Retracting piston force	[N]	435	660	1035	1765	2855	
Extracting piston force	[N]	505	790	1235	1960	3165	
Cushioning length	[mm]	11.5	15	17	16.5	19.5	
Cushioning energy	[J]	4.8	9	15	27	54	
Weight	0 mm stroke	[kg]	0.5	0.65	1.06	1.42	2.37
	+10 mm stroke	[kg]	0.022	0.032	0.047	0.054	0.085
Stroke max.	[mm]	1600	1900	2100	2500	2800	
Working pressure min./max.	[bar]	1.5 - 10	1.5 - 10	1.5 - 10	1.5 - 10	1.5 - 10	

Piston Ø	[mm]	100	125			
Retracting piston force	[N]	4635	7220			
Extracting piston force	[N]	4945	7725			
Cushioning length	[mm]	19.5	22			
Cushioning energy	[J]	88	140			
Weight	0 mm stroke	[kg]	3.51	6.72		
	+10 mm stroke	[kg]	0.1	0.15		
Stroke max.	[mm]	2800	2750			
Working pressure min./max.	[bar]	1.5 - 10	1.5 - 10			

Piston rod cylinders ▶ Standard cylinders

Profile cylinder ISO 15552, Series PRA

▶ Ports: G 1/8 - G 1/2 ▶ double-acting ▶ with magnetic piston ▶ Cushioning: pneumatically, adjustable ▶ Piston rod: external thread ▶ silicone-free ▶ heat resistant

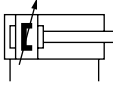
	Piston Ø Piston rod thread Ports Piston rod Ø	32	40	50	63	80	
		M10x1,25 G 1/8 12	M12x1,25 G 1/4 16	M16x1,5 G 1/4 20	M16x1,5 G 3/8 20	M20x1,5 G 3/8 25	
	Stroke 25	R412014229	R412014243	R412014257	R412014278	R412014304	
	50	R412014230	R412014168	R412014258	R412014225	R412014305	
	80	R412014231	R412014170	R412014162	R412014279	R412014306	
	100	R412014232	R412014244	R412014259	R412014280	R412014307	
	125	R412014182	R412014216	R412014260	R412014281	R412014308	
	160	R412014233	R412014245	R412014261	R412014282	R412014309	
	200	R412014234	R412014246	R412014262	R412014283	R412014210	
	250	R412014235	R412014247	R412014263	R412014214	R412014219	
	320	R412014236	R412014248	R412014183	R412014284	R412014310	
	400	R412014237	R412013926	R412014264	R412014285	R412014206	
	500	R412014238	R412014249	R412014265	R412014286	R412014311	
		Piston Ø Piston rod thread Ports Piston rod Ø	100	125			
			M20x1,5 G 1/2 25	M27x2 G 1/2 32			
	Stroke 25		R412014327	R480605337			
	50		R412014328	R480605338			
	80		R412014329	R480605339			
	100		R412014330	R480605340			
	125		R412014331	R480605341			
	160		R412014332	R480605342			
	200		R412014333	R480605343			
250		R412013911	R480605146				
320		R412014334	R480605344				
400		R412014335	R480605345				
500		R412014336	R480605346				

Configurable product



This product is configurable. Please use our Internet configurator at <http://www.aventics.com> or contact the nearest AVENTICS sales office.

Profile cylinder ISO 15552, Series PRA

▶ Ports: G 1/8 - G 1/2 ▶ double-acting ▶ with magnetic piston ▶ Cushioning: pneumatically, adjustable ▶ Piston rod: external thread ▶ silicone-free ▶ heat resistant

Cushioning diagram

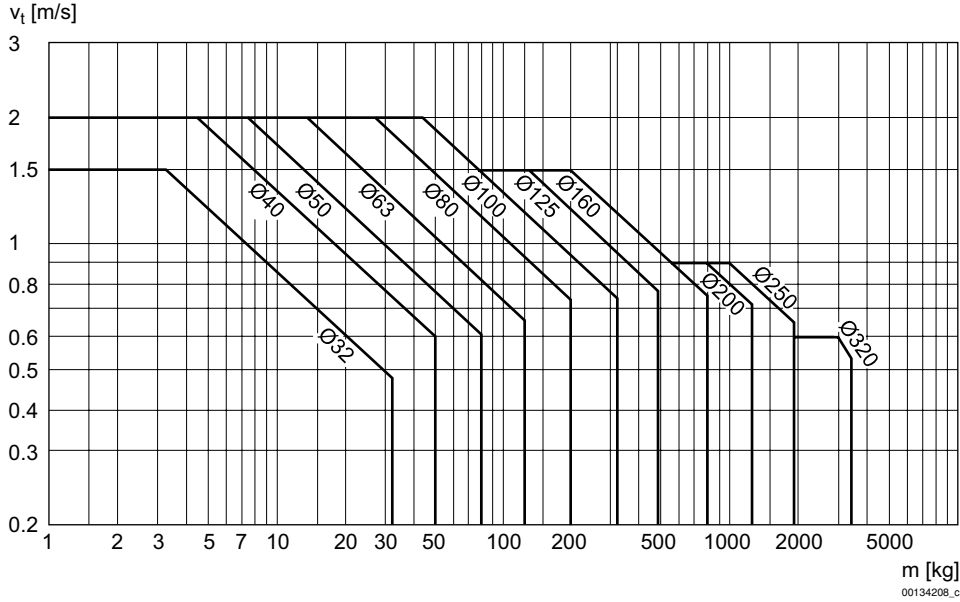

v = Piston velocity [m/s]
m = Cushionable mass [kg]

Dimensions

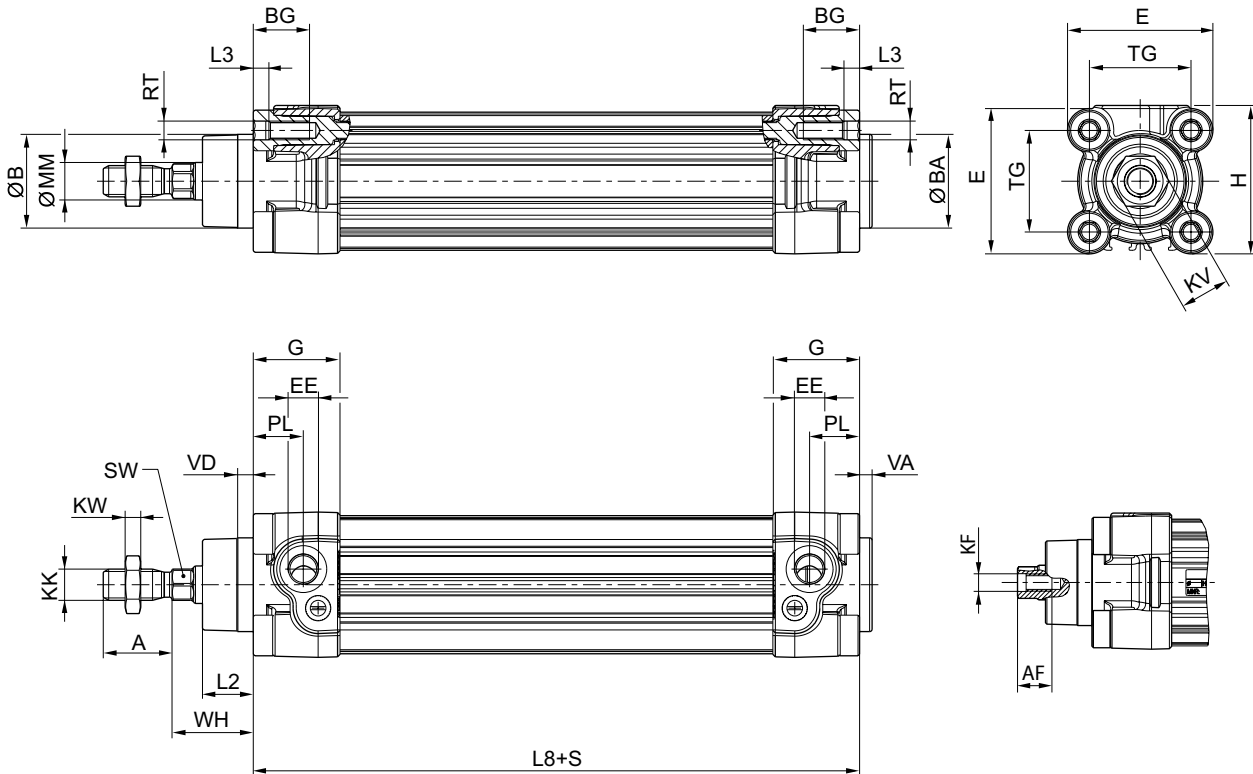

S = stroke

00134208

Piston rod cylinders ▶ Standard cylinders
Profile cylinder ISO 15552, Series PRA

▶ Ports: G 1/8 - G 1/2 ▶ double-acting ▶ with magnetic piston ▶ Cushioning: pneumatically, adjustable ▶ Piston rod: external thread ▶ silicone-free ▶ heat resistant

Piston Ø	A -2	AF+1	ØB d11	ØBA d11	BG min.	E	EE	G	H	KF	KK
32	22	12	30	30	16	46.5	G 1/8	27.75	47.5	M6	M10x1,25
40	24	13.5	35	35	16	53	G 1/4	33.25	53	M8	M12x1,25
50	32	17	40	40	16	65	G 1/4	31	65	M10	M16x1,5
63	32	17	45	45	16	75	G 3/8	38.25	75	M10	M16x1,5
80	40	21	45	45	17	95	G 3/8	38.25	95	M12	M20x1,5
100	40	21	55	55	17	115	G 1/2	42.25	115	M12	M20x1,5
125	54	28	60	60	20	140	G 1/2	53.85	140	M16	M27x2

Piston Ø	KV	KW	ØMM f8	PL	L2	L3 ±0,5	L8	RT	SW	TG	VA -1	VD
32	16	5	12	16	16.25	4.5	94±0,4	M6	10	32,5±0,5	4	5
40	18	6	16	20	18.25	4.5	105±0,7	M6	13	38±0,5	4	5
50	24	8	20	19	25	4.5	106±0,7	M8	17	46,5±0,6	4	5
63	24	8	20	24	25	4.5	121±0,8	M8	17	56,5±0,7	4	5
80	30	10	25	23.5	33	0	128±0,8	M10	22	72±0,7	4	5
100	30	10	25	25	36	0	138±1	M10	22	89±0,7	4	5
125	41	13.5	32	33	45	0	160±1	M12	27	110±1,1	6	7

Piston Ø	WH											
32	26±1,4											
40	30±1,4											
50	37±1,4											
63	37±1,8											
80	46±1,8											
100	51±1,8											
125	65±2,2											

Profile cylinder ISO 15552, Series PRA

▶ Ports: G 1/8 - G 1/2 ▶ double-acting ▶ Cushioning: pneumatically, adjustable ▶ Piston rod: external thread
▶ silicone-free ▶ heat resistant



00134193

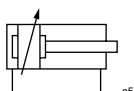

Standards	ISO 15552
Compressed air connection	Internal thread
Working pressure min./max.	2 bar / 10 bar
Ambient temperature min./max.	-10°C / +150°C
Medium temperature min./max.	-10°C / +150°C
Medium	Compressed air
Max. particle size	50 µm
Oil content of compressed air	0 mg/m ³ - 5 mg/m ³
Pressure for determining piston forces	6,3 bar

Materials:	
Cylinder tube	Aluminum, anodized
Piston rod	Stainless steel
Front cover	Die-cast aluminum
End cover	Die-cast aluminum
Seal	Fluorocautchouc
Nut for piston rod	Steel, galvanized
Scraper	Fluorocautchouc

Technical Remarks

- The pressure dew point must be at least 15 °C under ambient and medium temperature and may not exceed 3 °C.
- The oil content of compressed air must remain constant during the life cycle.
- Use only the approved oils from AVENTICS, see chapter „Technical information“.

Piston Ø	[mm]	32	40	50	63	80	
Retracting piston force	[N]	435	660	1035	1765	2855	
Extracting piston force	[N]	505	790	1235	1960	3165	
Cushioning length	[mm]	11.5	15	17	16.5	19.5	
Cushioning energy	[J]	4.8	9	15	27	54	
Weight	0 mm stroke	[kg]	0.5	0.65	1.06	1.42	2.37
	+10 mm stroke	[kg]	0.022	0.032	0.047	0.054	0.085
Stroke max.	[mm]	1600	1900	2100	2500	2800	
Working pressure min./max.	[bar]	1.5 - 10	1.5 - 10	1.5 - 10	1.5 - 10	1.5 - 10	

Piston Ø	[mm]	100	125			
Retracting piston force	[N]	4635	7220			
Extracting piston force	[N]	4945	7725			
Cushioning length	[mm]	19.5	22			
Cushioning energy	[J]	88	140			
Weight	0 mm stroke	[kg]	3.51	6.72		
	+10 mm stroke	[kg]	0.1	0.15		
Stroke max.	[mm]	2800	2750			
Working pressure min./max.	[bar]	1.5 - 10	1.5 - 10			

Piston rod cylinders ▶ Standard cylinders

Profile cylinder ISO 15552, Series PRA

- ▶ Ports: G 1/8 - G 1/2 ▶ double-acting ▶ Cushioning: pneumatically, adjustable ▶ Piston rod: external thread
- ▶ silicone-free ▶ heat resistant

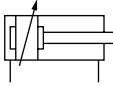
	Piston Ø Piston rod thread Ports Piston rod Ø	32	40	50	63	80	
		M10x1,25 G 1/8 12	M12x1,25 G 1/4 16	M16x1,5 G 1/4 20	M16x1,5 G 3/8 20	M20x1,5 G 3/8 25	
	Stroke 25	R480144202	R480041108	R480147979	R480147990	R480144198	
	50	R480147959	R480147968	R480147980	R480147991	R480148001	
	80	R480040989	R480147969	R480147981	R480147992	R480148002	
	100	R480147960	R480147970	R480147982	R480147993	R480147611	
	125	R480147961	R480147971	R480147983	R480147994	R480148003	
	160	R480147962	R480147972	R480147984	R480147995	R480148004	
	200	R480147963	R480147973	R480147985	R480144714	R480147052	
	250	R480147964	R480147974	R480147986	R480147996	R480148005	
	320	R480147965	R480147975	R480147987	R480147997	R480146313	
	400	R480147966	R480147976	R480147988	R480147998	R480042946	
	500	R480147967	R480147977	R480147989	R480147999	R480148009	
		Piston Ø Piston rod thread Ports Piston rod Ø	100 M20x1,5 G 1/2 25	125 M27x2 G 1/2 32			
	Stroke 25	R480148011	R480170695				
	50	R480148012	R480157264				
	80	R480148013	R480163258				
	100	R480148014	R480153677				
	125	R480148015	R480155595				
	160	R480148016	R480170774				
	200	R480148017	R480165969				
	250	R480148018	R480158304				
320	R480148019	R480170775					
400	R480148020	R480170776					
500	R480147194	R480149365					

Configurable product



This product is configurable. Please use our Internet configurator at <http://www.aventics.com> or contact the nearest AVENTICS sales office.

Profile cylinder ISO 15552, Series PRA

- ▶ Ports: G 1/8 - G 1/2 ▶ double-acting ▶ Cushioning: pneumatically, adjustable ▶ Piston rod: external thread
- ▶ silicone-free ▶ heat resistant

Cushioning diagram

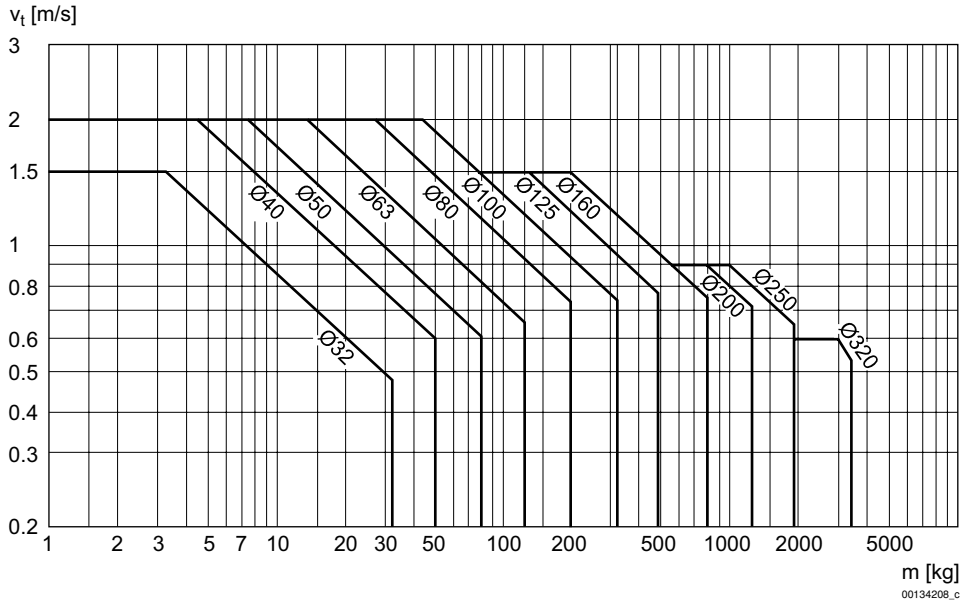

v = Piston velocity [m/s]
 m = Cushionable mass [kg]

Dimensions

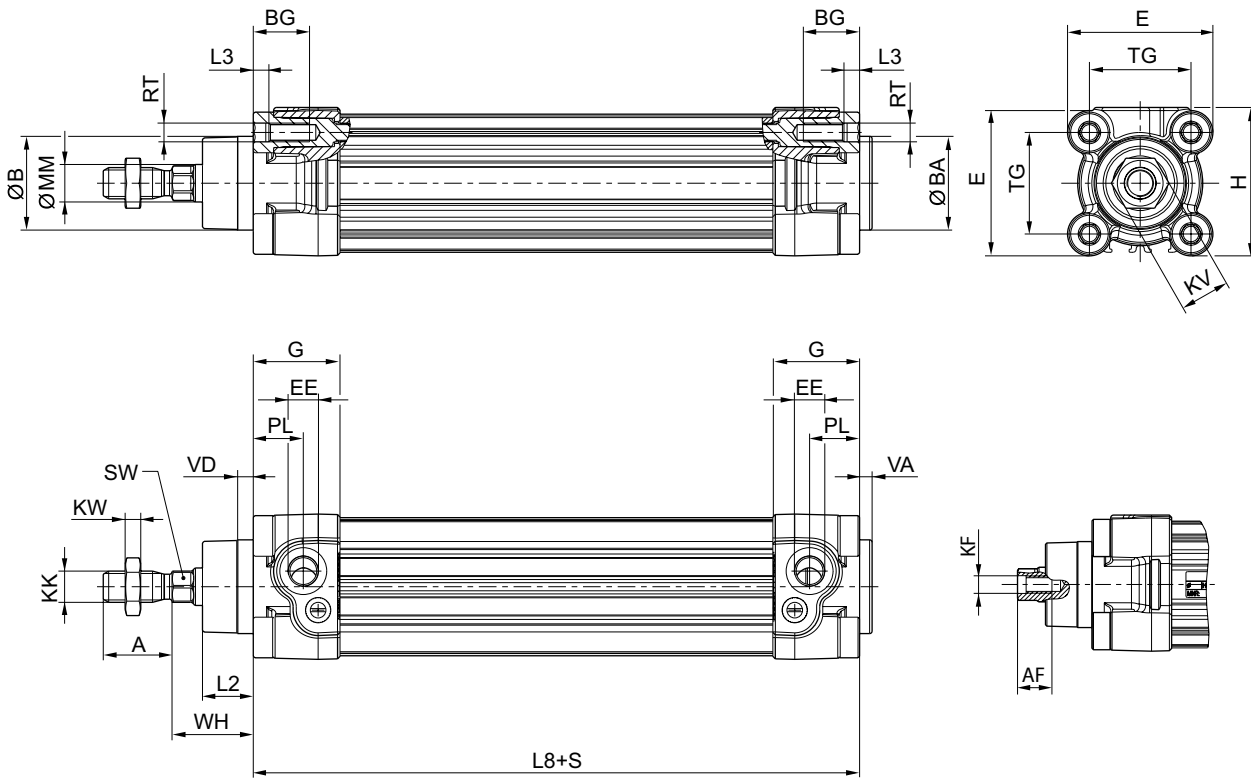

S = stroke

00134208

Piston rod cylinders ▶ Standard cylinders

Profile cylinder ISO 15552, Series PRA

- ▶ Ports: G 1/8 - G 1/2 ▶ double-acting ▶ Cushioning: pneumatically, adjustable ▶ Piston rod: external thread
 ▶ silicone-free ▶ heat resistant

Piston Ø	A -2	AF+1	ØB d11	ØBA d11	BG min.	E	EE	G	H	KF	KK
32	22	12	30	30	16	46.5	G 1/8	27.75	47.5	M6	M10x1,25
40	24	13.5	35	35	16	53	G 1/4	33.25	53	M8	M12x1,25
50	32	17	40	40	16	65	G 1/4	31	65	M10	M16x1,5
63	32	17	45	45	16	75	G 3/8	38.25	75	M10	M16x1,5
80	40	21	45	45	17	95	G 3/8	38.25	95	M12	M20x1,5
100	40	21	55	55	17	115	G 1/2	42.25	115	M12	M20x1,5
125	54	28	60	60	20	140	G 1/2	53.85	140	M16	M27x2

Piston Ø	KV	KW	ØMM f8	PL	L2	L3 ±0,5	L8	RT	SW	TG	VA -1	VD
32	16	5	12	16	16.25	4.5	94±0,4	M6	10	32,5±0,5	4	5
40	18	6	16	20	18.25	4.5	105±0,7	M6	13	38±0,5	4	5
50	24	8	20	19	25	4.5	106±0,7	M8	17	46,5±0,6	4	5
63	24	8	20	24	25	4.5	121±0,8	M8	17	56,5±0,7	4	5
80	30	10	25	23.5	33	0	128±0,8	M10	22	72±0,7	4	5
100	30	10	25	25	36	0	138±1	M10	22	89±0,7	4	5
125	41	13.5	32	33	45	0	160±1	M12	27	110±1,1	6	7

Piston Ø	WH											
32	26±1,4											
40	30±1,4											
50	37±1,4											
63	37±1,8											
80	46±1,8											
100	51±1,8											
125	65±2,2											

Profile cylinder ISO 15552, Series PRA

▶ Low friction ▶ double-acting ▶ with magnetic piston ▶ Cushioning: pneumatically, adjustable ▶ Piston rod: external thread



00134193

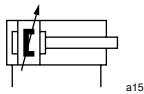

Standards	ISO 15552
Compressed air connection	Internal thread
Working pressure min./max.	1 bar / 10 bar
Ambient temperature min./max.	-20 °C / +80 °C
Medium temperature min./max.	-20 °C / +80 °C
Medium	Compressed air
Max. particle size	50 μm
Oil content of compressed air	0 mg/m ³ - 5 mg/m ³
Pressure for determining piston forces	6,3 bar

Materials:	
Cylinder tube	Aluminum, anodized
Piston rod	Stainless steel
Front cover	Die-cast aluminum
End cover	Die-cast aluminum
Seal	Nitrile butadiene rubber
Nut for piston rod	Steel, galvanized
Scraper	Nitrile butadiene rubber

Technical Remarks

- The pressure dew point must be at least 15 °C under ambient and medium temperature and may not exceed 3 °C.
- The oil content of compressed air must remain constant during the life cycle.
- Use only the approved oils from AVENTICS, see chapter „Technical information“.
- The extracting breakaway pressure is determined with the piston in center position.

Piston Ø	[mm]	32	40	50	63	80
Retracting piston force	[N]	435	660	1035	1765	2855
Extracting piston force	[N]	505	790	1235	1960	3165
Extracting breakaway pressure	[bar]	0.09	0.07	0.05	0.05	0.04
Cushioning length	[mm]	11.5	15	17	16.5	19.5
Cushioning energy	[J]	4.8	9	15	27	54
Weight	0 mm stroke	0.5	0.65	1.06	1.42	2.37
	+10 mm stroke	0.022	0.032	0.047	0.054	0.085
Stroke max.	[mm]	1600	1900	2100	2500	2800

Piston Ø	[mm]	100	125			
Retracting piston force	[N]	4635	7220			
Extracting piston force	[N]	4945	7725			
Extracting breakaway pressure	[bar]	0.04	0.06			
Cushioning length	[mm]	19.5	22			
Cushioning energy	[J]	88	140			
Weight	0 mm stroke	3.51	6.72			
	+10 mm stroke	0.1	0.15			
Stroke max.	[mm]	2800	2750			

Configurable product



This product is configurable. Please use our Internet configurator at <http://www.aventics.com> or contact the nearest AVENTICS sales office.

Piston rod cylinders ▶ Standard cylinders

Profile cylinder ISO 15552, Series PRA

▶ Low friction ▶ double-acting ▶ with magnetic piston ▶ Cushioning: pneumatically, adjustable ▶ Piston rod: external thread

Cushioning diagram

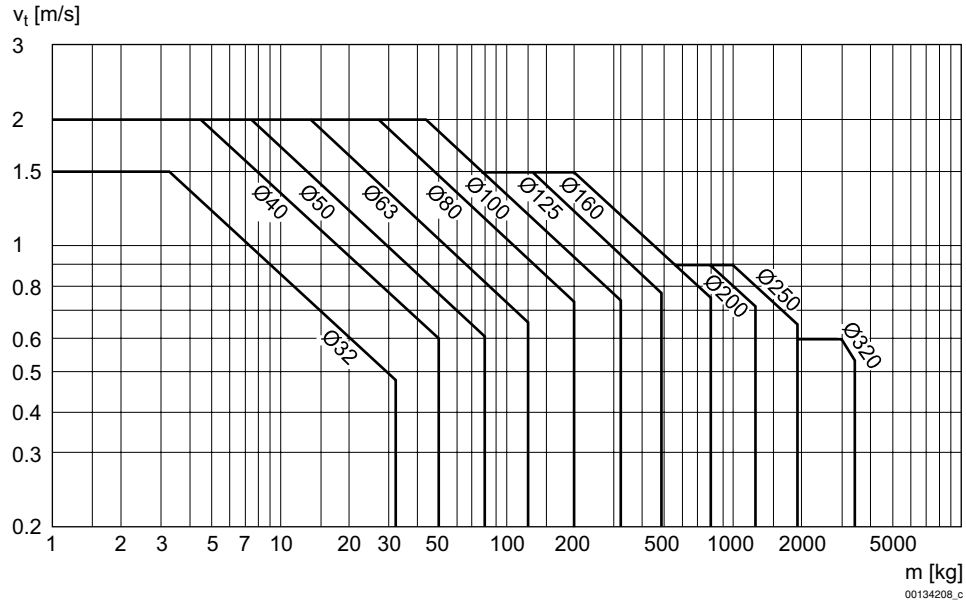

v = Piston velocity [m/s]
m = Cushionable mass [kg]

Stick-slip effect in unpressurized state

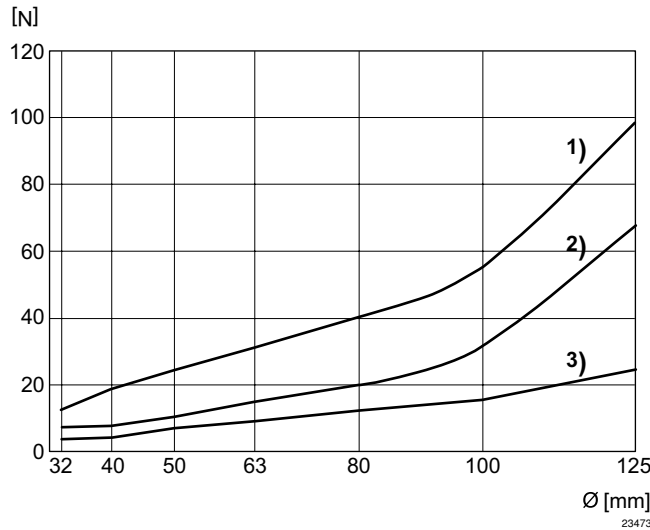

- 1) Standard PRA
- 2) Low-friction PRA (with magnet)
- 3) Low-friction TRB (without magnet)

Stick-slip effect, internal cylinder pressure on both sides 6,3 bar

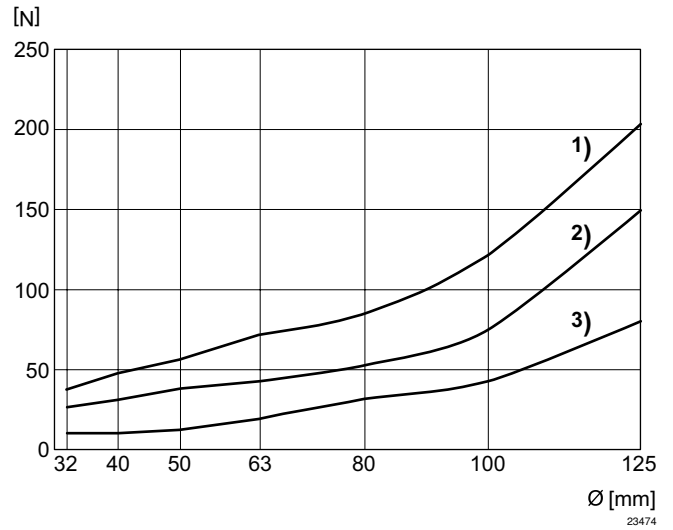

Profile cylinder ISO 15552, Series PRA

▶ Low friction ▶ double-acting ▶ with magnetic piston ▶ Cushioning: pneumatically, adjustable ▶ Piston rod: external thread

Dimensions

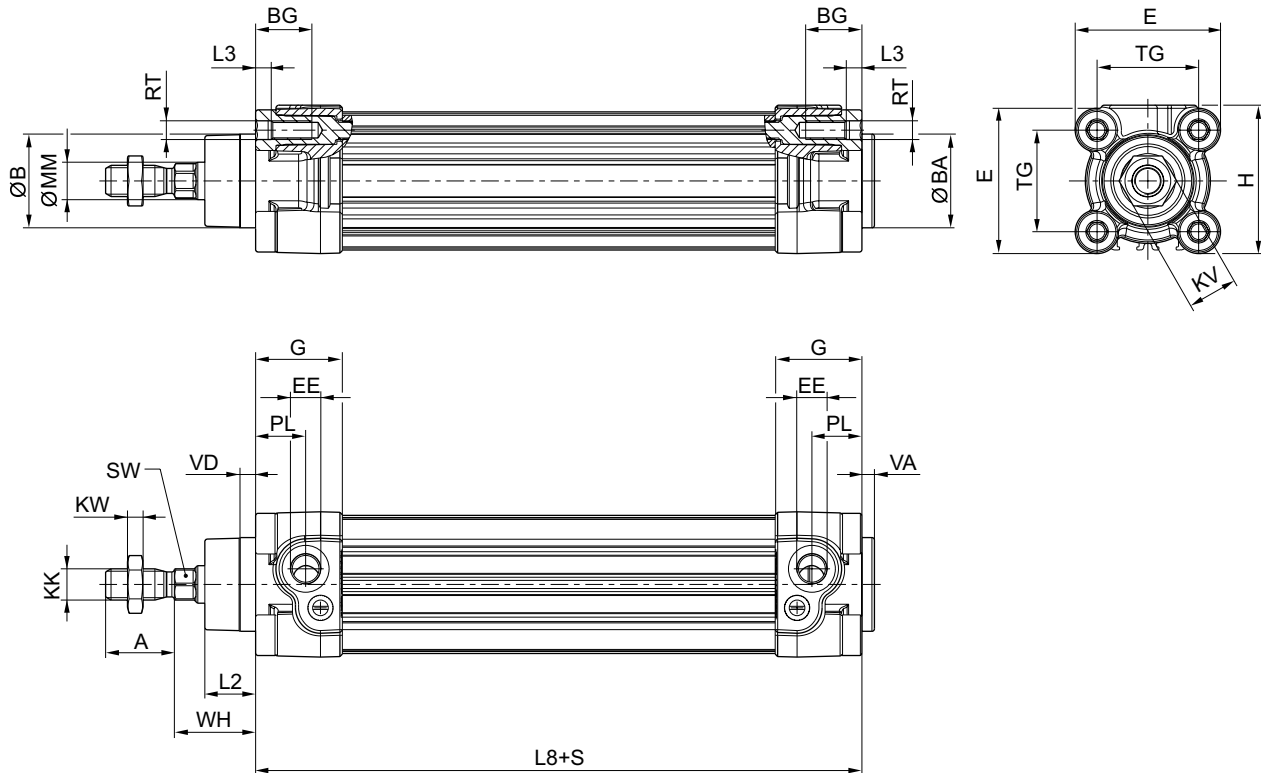

00134208_b

S = stroke

Ø	A -2	ØB d11	ØBA d11	BG min.	E	EE	G	H	KK	KV
32	22	30	30	16	46.5	G 1/8	27.75	47.5	M10x1,25	16
40	24	35	35	16	53	G 1/4	33.25	53	M12x1,25	18
50	32	40	40	16	65	G 1/4	31	65	M16x1,5	24
63	32	45	45	16	75	G 3/8	38.25	75	M16x1,5	24
80	40	45	45	17	95	G 3/8	38.25	95	M20x1,5	30
100	40	55	55	17	115	G 1/2	42.25	115	M20x1,5	30
125	54	60	60	20	140	G 1/2	53.85	140	M27x2	41

Ø	KW	ØMM f8	PL	L2	L3 ±0,5	L8	RT	SW	TG	VA -1
32	5	12	16	16.25	4.5	94±0,4	M6	10	32,5±0,5	4
40	6	16	20	18.25	4.5	105±0,7	M6	13	38±0,5	4
50	8	20	19	25	4.5	106±0,7	M8	17	46,5±0,6	4
63	8	20	24	25	4.5	121±0,8	M8	17	56,5±0,7	4
80	10	25	23.5	33	0	128±0,8	M10	22	72±0,7	4
100	10	25	25	36	0	138±1	M10	22	89±0,7	4
125	13.5	32	33	45	0	160±1	M12	27	110±1,1	6

Ø	VD	WH								
32	5	26±1,4								
40	5	30±1,4								
50	5	37±1,4								
63	5	37±1,8								
80	5	46±1,8								
100	5	51±1,8								
125	7	65±2,2								

Part numbers marked in bold are available from the central warehouse in Germany, see the shopping basket for more detailed information

Pneumatics catalog, online PDF, as of 2017-05-02, ©AVENTICS S.à r.l., subject to change

Piston rod cylinders ▶ Standard cylinders

Profile cylinder ISO 15552, Series PRA-MS
▶ Modular sealing system

Standards

ISO 15552

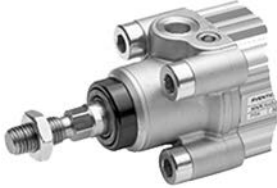

For additional technical data please see the relevant data sheets for the standard version.

PRA_MS

Configurable product



This product is configurable. Please use our Internet configurator at <http://www.aventics.com> or contact the nearest AVENTICS sales office.

Piston Ø	Seal	Scraper	Ambient temperature min./max.
32	Acrylonitrile butadiene rubber	Polyester elastomer	-20 °C / + 80 °C
	Acrylonitrile butadiene rubber	Polytetrafluorethylene	-20 °C / + 80 °C
	Fluorocaoutchouc	Polytetrafluorethylene	-10 °C / + 120 °C
40-125	Acrylonitrile butadiene rubber	Polyester elastomer	-20 °C / + 80 °C
	Acrylonitrile butadiene rubber	Polytetrafluorethylene	-20 °C / + 80 °C
	Fluorocaoutchouc	Polytetrafluorethylene	-10 °C / + 120 °C
	Acrylonitrile butadiene rubber	Brass	-20 °C / + 80 °C
	Fluorocaoutchouc	Brass	-10 °C / + 120 °C

Profile cylinder ISO 15552, Series PRA-MS

▶ Modular sealing system

For cylinder diameters: 32-40 mm, Dimensions in mm

For cylinder diameters: 50-125 mm, Dimensions in mm

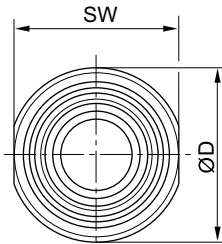
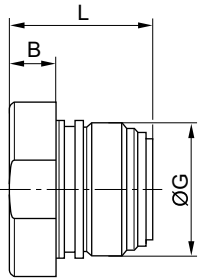
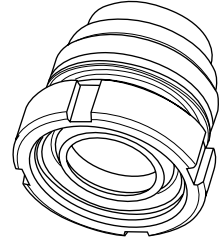
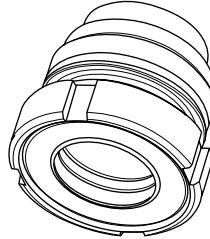
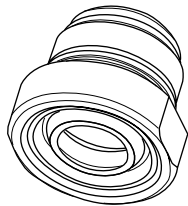
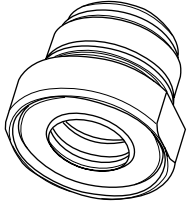

00126410_e

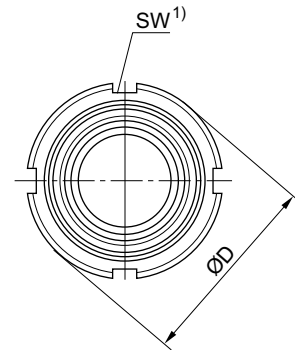
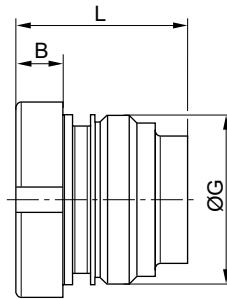

00126410_c

1) Can be mounted with hook wrench in accordance with DIN 1810 A

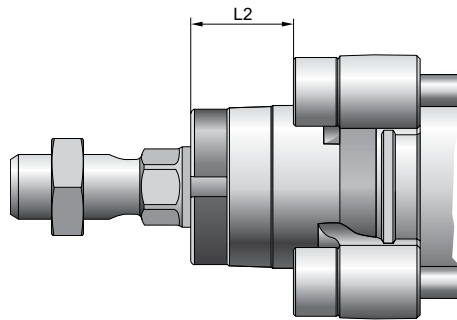

00126410_f

Ø	B	ØD	G	L	L2	SW							
32	6.7	24.5	M22x1	23	16.25	23							
40	9.2	34	M26x1,5	28.1	18.25	32							
50, 63	9	38.5	M33x2	33.5	25	40-42							
80, 100	10	44	M40x2	44	33	45-50							
125	12	57	M50x2	56	45	58-62							

Piston rod cylinders ▶ Standard cylinders

ISO 1552, Series PRA
Accessories

Accessories overview

Overview drawing

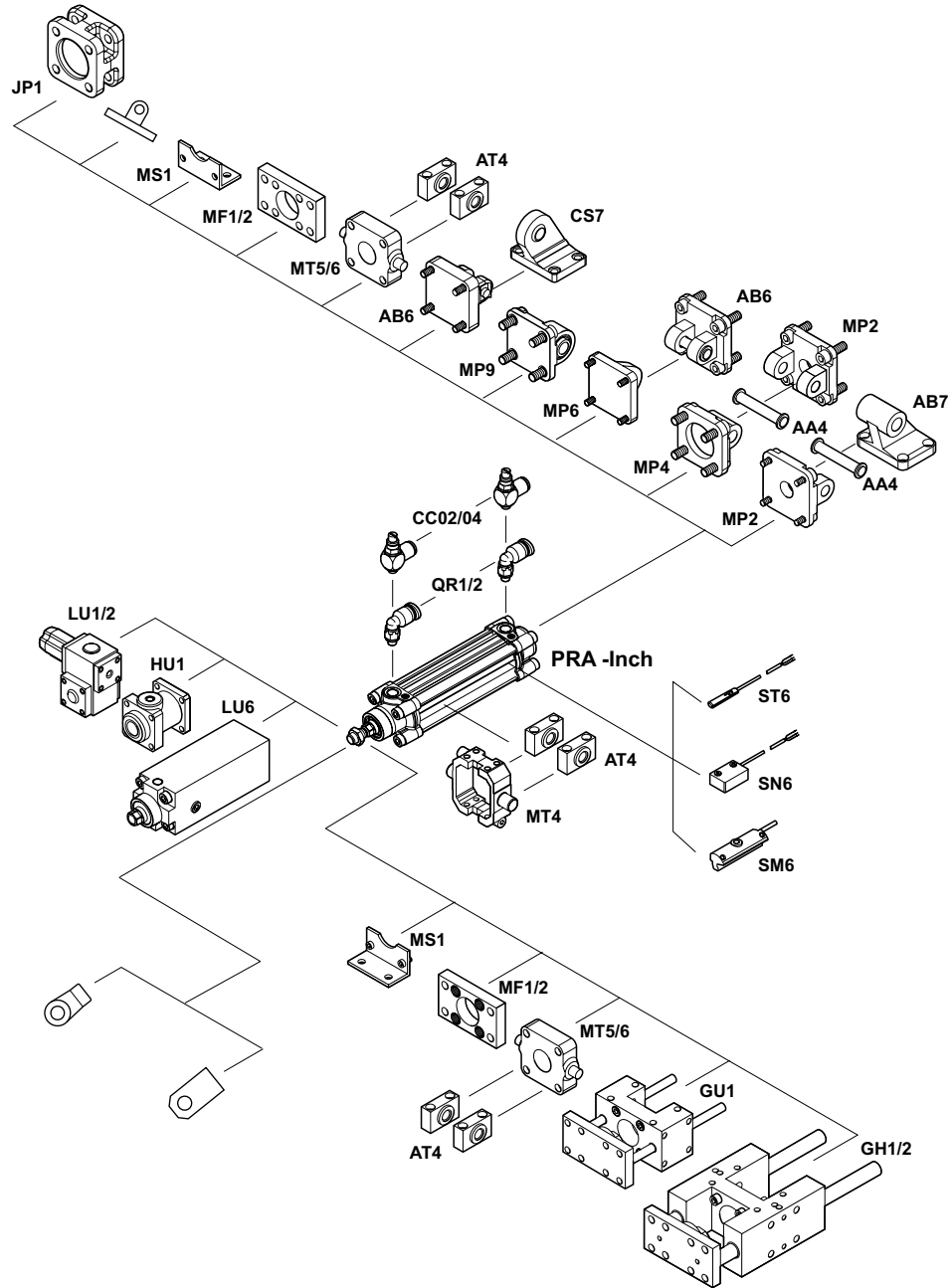

IM0043424

NOTE:

This overview drawing is only for orientation to see where the various accessory parts can be fastened to the cylinder. The illustration has been simplified for this purpose. It is thus not possible to derive the dimensions from this overview.

ISO 1552, Series PRA
Accessories

Piston rod cylinders ▶ Standard cylinders

ISO 15552, Series PRA
Accessories

Bearing block, Series AB7

▶ Cylinder mounting in accordance with ISO 15552



00105160

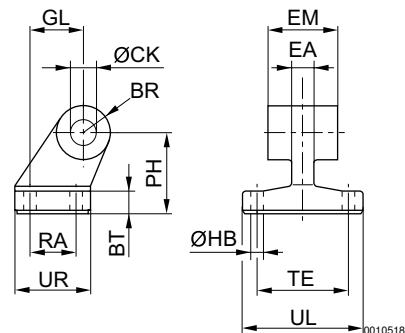

00105184

Part No.	Piston Ø	BR	BT	Ø CK H9	Ø HB H13	EM	GL JS14	EA 1)	PH JS15	RA JS14	TE JS14
1825805275	32	10	8	10	6.6	26 -0,2/-0,6	21	10	32	18	38
1825805276	40	11	10	12	6.6	28 -0,2/-0,6	24	12	36	22	41
1825805277	50	13	12	12	9	32 -0,2/-0,6	33	16	45	30	50
1825805278	63	15	12	16	9	40 -0,2/-0,6	37	16	50	35	52
1825805279	80	15	14	16	11	50 -0,2/-0,6	47	20	63	40	66
1825805280	100	19	15	20	11	60 -0,2/-0,6	55	20	71	50	76
1825805281	125	22,5	20	25	14	70 -0,5/-1,5	70	30	90	60	94

Part No.	UL 1)	UR 1)									
1825805275	51	31									
1825805276	54	35									
1825805277	65	45									
1825805278	67	50									
1825805279	86	60									
1825805280	96	70									
1825805281	124	90									

1) Max.
Material: Nodular graphite iron
Surface: galvanized

ISO 15552, Series PRA

Accessories

Bearing block, Series CS7

▶ Cylinder mounting in accordance with VDMA 24562 part 2



00105817

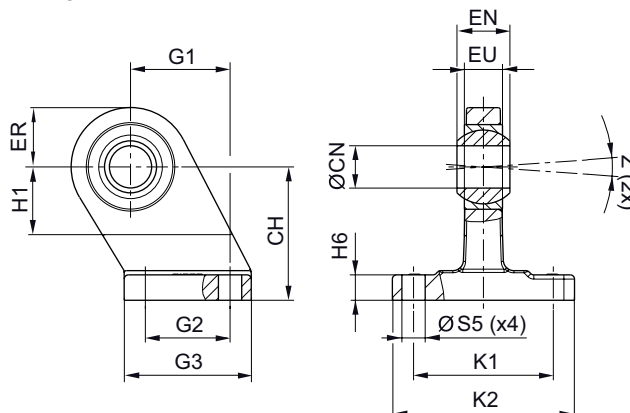

00105820

Part No.	Piston Ø	CH JS15	ØCN H7	EU 1)	EN -1,0	ER 1)	G1 JS14	G2 JS14	G3 1)	H1 2)	H6	K1 JS14
1827001784	32	32	10	10.5	14	16	21	18	31	16	9 ±1	38
1827001785	40	36	12	12	16	18	24	22	35	20	9 ±1	41
1827001786	50	45	16	15	21	21	33	30	45	22	11 ±1	50
1827001787	63	50	16	15	21	23	37	35	50	27	11 ±1	52
1827001788	80	63	20	18	25	28	47	40	60	31	12 ±1,5	66
1827001789	100	71	20	18	25	30	55	50	70	38	13 ±1,5	76
1827001790	125	90	30	25	37	40	70	60	90	40	17 ±1,5	94

Part No.	K2 1)	ØS5 H13	Z 2)									
1827001784	51	6.6	4°									
1827001785	54	6.6	4°									
1827001786	65	9	4°									
1827001787	67	9	4°									
1827001788	86	11	4°									
1827001789	96	11	4°									
1827001790	124	14	4°									

1) Max.

2) Min.

Material: Nodular graphite iron

Surface: galvanized

Piston rod cylinders ▶ Standard cylinders

ISO 1552, Series PRA
Accessories

Clevis mounting, Series AB6

▶ Cylinder mounting in accordance with ISO 1552

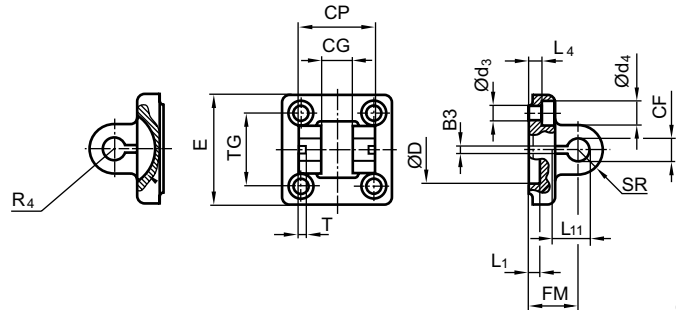

00105819

24547

Scope of delivery: clevis mounting incl. pivot pins and mounting screws

Part No.	Piston Ø	B3 ±0,2	Ø CF F7	CG D10	CP d12	Ø d3	Ø d4	Ø D	E	FM ±0,2	L1 1)	L4 ±0,5
1827001593	32	3.3	10	14	34	6.6	11	30	49	22	4.5	5.5
1827001594	40	4.3	12	16	40	6.6	11	35	55	25	4.5	5.5
1827001595	50	4.3	16	21	45	9	15	40	67	27	4.5	6.5
1827002024	63	4.3	16	21	51	9	15	45	77	32	4.5	6.5
1827001597	80	4.3	20	25	65	11	18	45	97	36	4.5	10
1827001598	100	4.3	20	25	75	11	18	55	117	41	4.5	10
1827001599	125	6.3	30	37	97	14	20	60	140	50	7	10

Part No.	L11 -0,5	R4	SR	T ±0,2	TG							
1827001593	16.5	17	11	3	32,5 ±0,2							
1827001594	18	20	12	4	38 ±0,2							
1827001595	23	22	15	4	46,5 ±0,2							
1827002024	23	25	15	4	56,5 ±0,2							
1827001597	27	30	20	4	72 ±0,2							
1827001598	27	32	20	4	89 ±0,2							
1827001599	40	42	26	6	110 ±0,3							

1) Min.
Material: Aluminum (forged)

Clevis mounting, Series MP2

▶ Cylinder mounting in accordance with ISO 1552

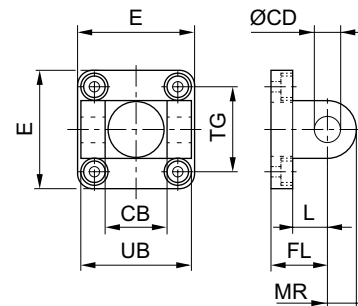

00130359

P523_025

Scope of delivery: clevis mounting incl. mounting screws

ISO 15552, Series PRA Accessories

Part No.	Piston Ø	CB H14	Ø CD H9	E	FL ±0,2	L 1)	MR 2)	UB h13	TG		
1827001289	32	26	10	49 ±1	22	12	10	45	32,5 ±0,2		
1827001290	40	28	12	53 ±1	25	15	13	52	38 ±0,2		
1827001291	50	32	12	63 ±1	27	15	13	60	46,5 ±0,2		
1827001500	63	40	16	73 ±1	32	18	17	70	56,5 ±0,2		
1827001293	80	50	16	98 ±1	36	20	17	90	72,0 ±0,2		
1827001294	100	60	20	115 ±1	41	25	18	110	89,0 ±0,2		
1827004862	125	70	25	140	50	30	26	130	110 ±0,3		

1) Min.

2) Max.

Material: Aluminum (forged)

Rear eye, Series MP4

▶ Cylinder mounting in accordance with ISO 15552 ▶ for clevis mounting MP2 and AB3



P523_024

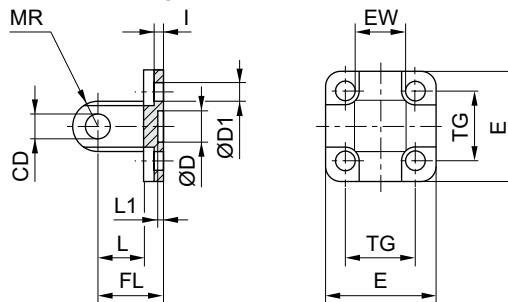

00126403_a

Scope of delivery: clevis incl. mounting screws

Part No.	Piston Ø	CD H9	Ø D	Ø D1	E	EW	FL ±0,2	I ±0,5	L 1)	L1 1)	MR 2)
1827001283	32	10	30 H11	6.6	48	26 -0,2/-0,6	22	5.5	12	4.5	10
1827001284	40	12	35 H11	6.6	53	28 -0,2/-0,6	25	5.5	15	4.5	12
1827001285	50	12	40 H11	9	63	32 -0,2/-0,6	27	6.5	15	4.5	12
1827020086	63	16	45 H11	9	73	40 -0,2/-0,6	32	6.5	20	4.5	16
1827001287	80	16	45 H11	11	98	50 -0,2/-0,6	36	10	20	4.5	16
1827001288	100	20	55 H11	11	115	60 -0,2/-0,6	41	10	25	4.5	20
1827004866	125	25	60 H11	14	140	70 -0,5/-1,2	50	10	30	7	26

Part No.	TG										
1827001283	32,5 ±0,2										
1827001284	38 ±0,2										
1827001285	46,5 ±0,2										
1827020086	56,5 ±0,2										
1827001287	72 ±0,2										
1827001288	89 ±0,2										
1827004866	110 ±0,3										

1) Min.

2) Max.

Material: Aluminum (forged)

Piston rod cylinders ▶ Standard cylinders

ISO 15552, Series PRA
Accessories

Rear eye, Series MP6

▶ Cylinder mounting in accordance with ISO 15552 ▶ With ball joint and foot



24548

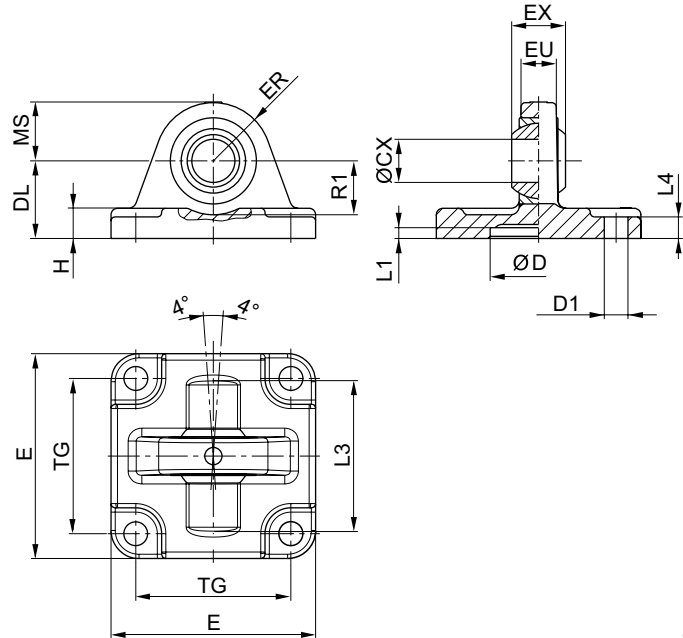

00126391

Scope of delivery: clevis incl. mounting screws

Part No.	Piston Ø	ØCX H7	ØD H11	ØD1 H13	DL ±0,2	E	EX -0,1	ER	EU	H	L1 1)	L3
1827001619	32	10	30	6.6	22	47	14	15	10.5	9	4.5	36
1827001620	40	12	35	6.6	25	53	16	18	12	9	4.5	42
1827001621	50	16	40	9	27	65	21	20	15	10.5	4.5	48
1827020087	63	16	45	9	32	75	21	23	15	10.5	4.5	55
1827001623	80	20	45	11	36	95	25	27	18	14	4.5	70
1827001624	100	20	55	11	41	115	25	30	18	15	4.5	80
1827001625	125	30	60	14	50	140	37	40	25	16	7	100

Part No.	L4	MS -0,5	R1 1)	TG	Weight [kg]							
1827001619	5.5	15	12	32,5 ±0,2	0.1							
1827001620	5.5	18	15	38 ±0,2	0.1							
1827001621	6.5	21	19	46,5 ±0,2	0.2							
1827020087	6.5	23	21	56,5 ±0,2	0.3							
1827001623	10	27	24	72 ±0,2	0.6							
1827001624	10	30	25	89 ±0,2	0.8							
1827001625	10	40	33	110 ±0,3	1.4							

1) Min.
Material: Aluminum (forged)

ISO 15552, Series PRA

Accessories

Rear eye, Series MP9

▶ With rubber bushing



IM0043848

Fig. 1

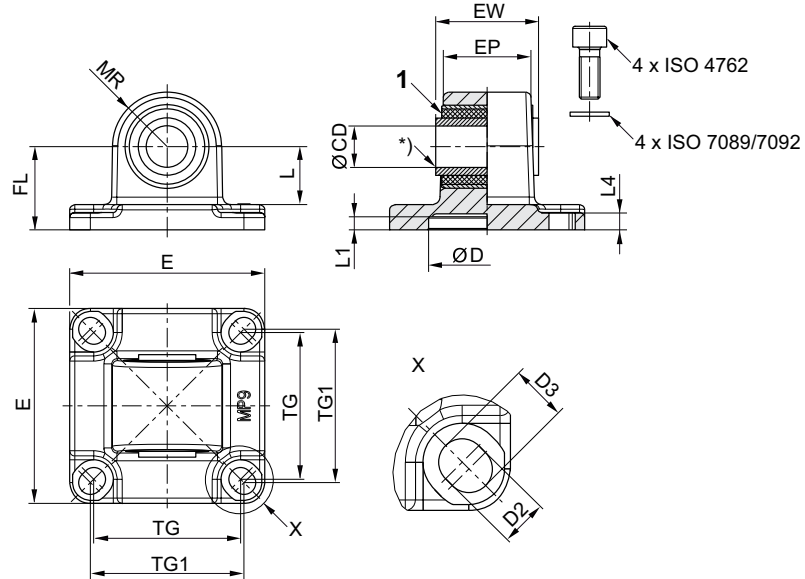
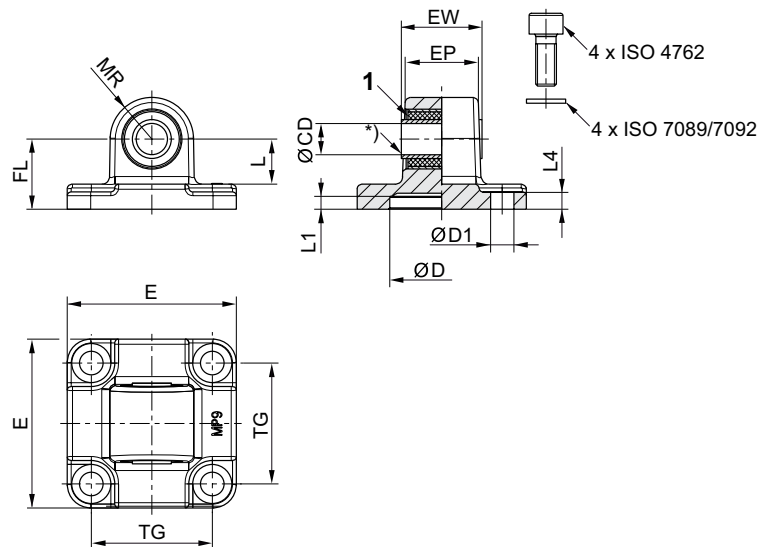

Fig. 2



IM0043825

1) Rubber bushing

* Plain bearing material: bronze (Ø125: steel, galvanized)

Scope of delivery: clevis incl. mounting screws

Part No.	Piston Ø	CD H11	CD H9	E	EW	EP	TG	TG1 ±0,2	FL ±0,2	MR	L 1)	L1
3683202000	25	10	–	40	17.5	14.5	26	27	20	12.5	14.8	3
3683203000	32	10	–	46	25.5	18.9	32.5	–	22	12.5	13.8	5
3683204000	40	–	12	53	27	23.5	38	40	25	15	16.3	5
3683205000	50	–	12	65	31	28	46.5	–	27	16	17.3	5
3683206000	63	–	16	75	39.5	33.5	56.5	59	32	21	22.3	5
3683208000	80	–	16	94.5	49.5	43	72	–	36	22	21.8	5

Part numbers marked in bold are available from the central warehouse in Germany, see the shopping basket for more detailed information

Pneumatics catalog, online PDF, as of 2017-05-02, ©AVENTICS S.à r.l., subject to change

Piston rod cylinders ▶ Standard cylinders

ISO 15552, Series PRA
Accessories

Part No.	Piston Ø	CD H11	CD H9	E	EW	EP	TG	TG1 ±0,2	FL ±0,2	MR	L 1)	L1
3683210000	100	–	20	114	59.5	54	89	90	41	25	25.8	5
R412015973	125	–	25	138	69.5	60	110	–	50	34	33.8	7.5

Part No.	L4	D H11	D1 H13	D2 -0,2	D3 -0,2	Standardization	Weight [kg]	Fig.	Note			
3683202000	3	18	–	5.5	6.2	ISO 21287	0.063	Fig. 1	2) 4)			
3683203000	5.5	30	6.6	–	–	ISO 15552	0.092	Fig. 2	3) 5)			
3683204000	5.5	35	–	6.6	8	ISO 15552	0.143	Fig. 1	3) 5)			
3683205000	6.5	40	9	–	–	ISO 15552	0.217	Fig. 2	5)			
3683206000	6.5	45	–	9	10.8	ISO 15552	0.411	Fig. 1	3) 5)			
3683208000	10	45	11	–	–	ISO 15552	0.64	Fig. 2	5)			
3683210000	10	55	–	11	11.7	ISO 15552	0.956	Fig. 1	3) 5)			
R412015973	10	60	13.5	–	–	ISO 15552	1.37	Fig. 2	5)			

- 1) Min.
- 2) CAD files *_iso.* (suitable for cylinders according to ISO 21287) and *_167.* (suitable for 167 series cylinders)
- 3) suitable for 167 series cylinders
- 4) Material: Die-cast aluminum
- 5) Material: Aluminum (forged)

Center trunnion mounting, Series MT4
▶ for Series PRA



00122726

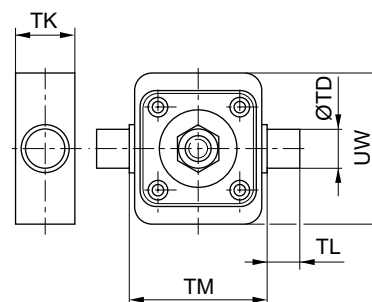

00126406

Part No.	Piston Ø	For series	TD e9	TK 1)	TL h14	TM h14	UW				
1827003991	32	PRA	12	22	12	50	70				
1827003992	40	PRA	16	28	16	63	78				
1827003993	50	PRA	16	28	16	75	96				
1827003994	63	PRA	20	35	20	90	108				
1827003995	80	PRA	20	35	20	110	130				
1827003996	100	PRA	25	46	25	132	150				
1827003997	125	PRA	25	46	25	160	171				

- 1) Max.
- Material: Aluminum

ISO 15552, Series PRA
 Accessories

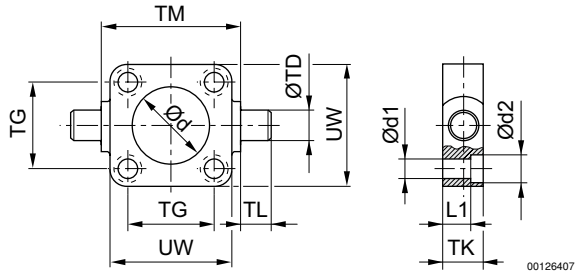
Trunnion mounting, front or rear, Series MT5, MT6

The delivered product may vary from that in the illustration.
 Scope of delivery: trunnion mounting incl. mounting screws

00128925

00126407

Part No.	Piston Ø	For series	Ø d H11	Ø d1	Ø d2	L1	TD e9	TG ±0,2	TK	TL h14	TM h14
1827001609	32	CCI CVI CCL-IC/-IS ICL PRA/TRB	30	6.6	11	7.5	12	32.5	16	12	50
1827001610	40	CCI CVI CCL-IC/-IS ICL PRA/TRB	35	6.6	11	7.5	16	38	20	16	63
1827001611	50	CCI CVI CCL-IC/-IS ICL PRA/TRB	40	9	15	10	16	46.5	24	16	75
1827002046	63	CCI CVI CCL-IC/-IS ICL PRA/TRB	45	9	15	10	20	56.5	24	20	90
1827001613	80	CCI CVI CCL-IC/-IS ICL PRA/TRB	45	11	18	16	20	72	28	20	110
1827001614	100	CCI CVI CCL-IC/-IS ICL PRA/TRB	55	11	18	25.5	25	89	38	25	132
1827001615	125	CVI ICL CCL-IS PRA TRB	60	14	20	34	25	110	46	25	160

Part No.	Piston Ø	UW									
1827001609	32	48									
1827001610	40	56									
1827001611	50	65									
1827002046	63	75									
1827001613	80	100									

Material: Nodular graphite iron
 Surface: galvanized

Piston rod cylinders ▶ Standard cylinders

ISO 15552, Series PRA Accessories

Part No.	Piston Ø	UW										
1827001614	100	120										
1827001615	125	145										

Material: Nodular graphite iron
Surface: galvanized

Bearing brackets MT4, MT5, MT6, Series AT4

▶ Cylinder mounting in accordance with ISO 15552 ▶ for Series CCI, CCL-IC, ICL, KPZ, PRA/TRB

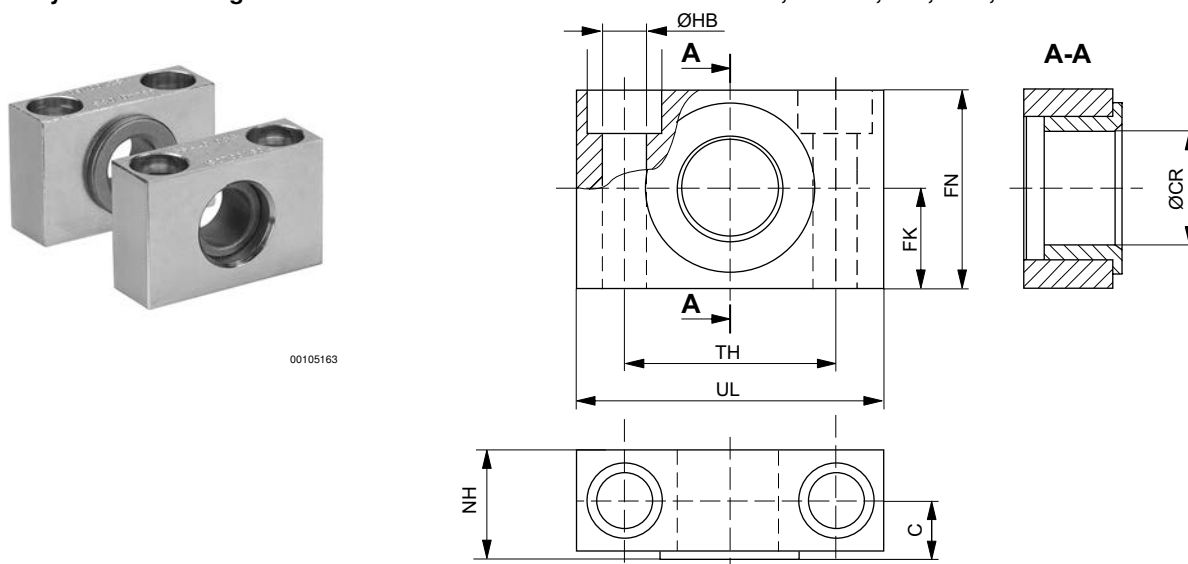

Part No.	Piston Ø	For series	UL	NH	TH	C	CR H9	HB H13	FN	FK
1827001603	20, 25, 32	CCI CCL-IC ICL KPZ PRA/TRB	46	18	32 ±0,2	10.5	12	6.6	30	15 ±0,1
1827001604	40, 50	CCI CCL-IC ICL KPZ PRA/TRB	55	21	36 ±0,2	12	16	9	36	18 ±0,1
1827001605	63, 80	CCI CCL-IC ICL KPZ PRA/TRB	65	23	42 ±0,2	13	20	11	40	20 ±0,1
1827001606	100, 125	CCI CCL-IC ICL KPZ PRA/TRB	75	28.5	50 ±0,2	16	25	14	50	25 ±0,1

Part numbers marked in bold are available from the central warehouse in Germany, see the shopping basket for more detailed information

Pneumatics catalog, online PDF, as of 2017-05-02, ©AVENTICS S.à r.l., subject to change

ISO 1552, Series PRA Accessories

Part No.	Piston Ø	Plain bearing	Delivery quantity [Piece]								
1827001603	20, 25, 32	Sintered bronze	2								
1827001604	40, 50	Sintered bronze	2								
1827001605	63, 80	Sintered bronze	2								
1827001606	100, 125	Sintered bronze	2								

Material: Steel
Surface: galvanized

Eye brackets



P300_012

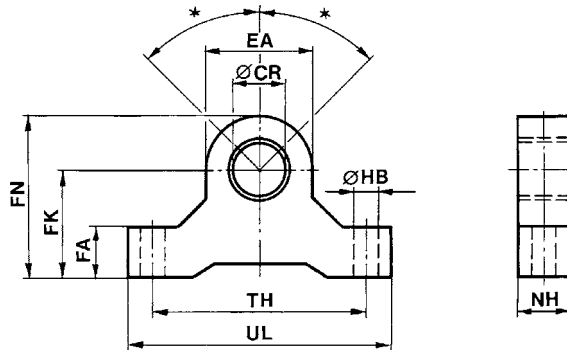

D300_011

* Max. pendulum movement for cylinders with rear eye MP6 with ball joint: $\pm 45^\circ$

Part No.	Ø CR H8	EA	FA	FK $\pm 0,1$	FN	HB	NH	TH	UL			
3671202000	10	16	10	21	29	5.5	10	27	37			
3671203000	12	19	11	22	32	6.6	11	44	55			
3671204000	16	28	16	35	49	9	16	65	82			
3671206000	20	38	19	40	59	9	19	80	99			
3671212000	30	56	28	57	88	13	28	114	142			

Material: Aluminum

Piston rod cylinders ▶ Standard cylinders

ISO 15552, Series PRA
Accessories

Flange mounting, Series MF1, MF2

▶ Cylinder mounting in accordance with ISO 15552

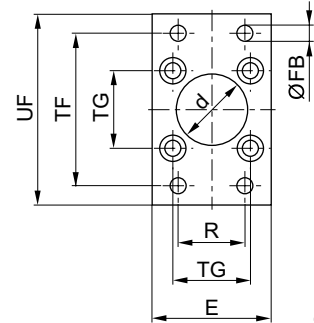
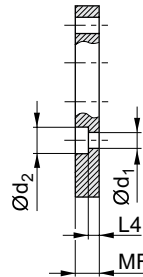

00126399

00105812

Scope of delivery: flange mounting incl. mounting screws

Part No.	Piston Ø	Ød H11	Ød1	Ød2	E 1)	ØFB	L4	MF	R	TF	TG
1827001277	32	30	6.6	11	50	7	4.5	10	32	64	32,5 ±0,2
1827001278	40	35	6.6	11	55	9	4.5	10	36	72	38 ±0,2
1827001279	50	40	9	15	65	9	6	12	45	90	46,5 ±0,2
1827001499	63	45	9	15	75	9	6	12	50	100	56,5 ±0,2
1827001281	80	45	11	18	100	12	9	16	63	126	72 ±0,2
1827001282	100	55	11	18	120	14	9	16	75	150	89 ±0,2
1827004861	125	60	14	20	140	16	10.5	20	90	180	110 ±0,3

Part No.	UF										
1827001277	80										
1827001278	90										
1827001279	110										
1827001499	125										
1827001281	154										
1827001282	186										
1827004861	220										

1) Max.
Material: Steel
Surface: galvanized

ISO 15552, Series PRA Accessories

Intermediate flange, Series JP1 ▶ for multi-position cylinders



00135554

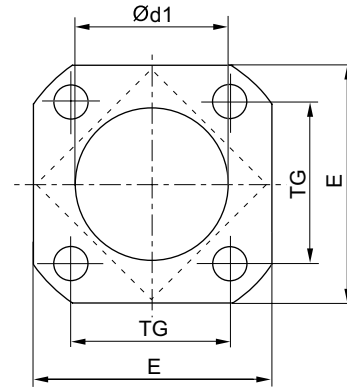
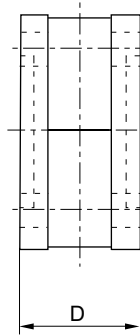

00135553

Scope of delivery: Incl. mounting screws

Part No.	Piston Ø	D	Ø d1 N7	E	TG							
1827020247	32	27	30	47	32.5							
1827020248	40	27	35	53	38							
1827020249	50	32	40	65	46.5							
1827020250	63	28	45	75	56.5							
1827020251	80	38	45	95	72							
1827020252	100	38	55	115	89							
1827020253	125	44	60	140	110							

Material: Aluminum

Foot mounting, Series MS1



00105808

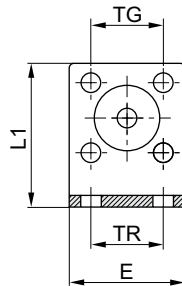

Ø16

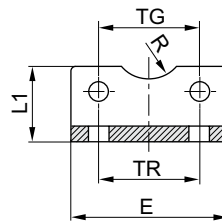

Ø20 - 320

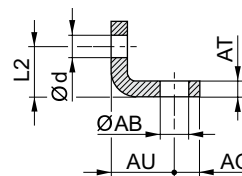

00126387

Scope of delivery: 2 foot mountings incl. mounting screws

Part No.	Piston Ø	For series	ØAB	AO	AT	AU ±0,2	Ød	E	L1	L2
1827001271	32	ICL CCI CCL-IC/-IS PRA/TRB CVI	7	8	4 ±0,3	24	6.6	48	25	15.5

Part numbers marked in bold are available from the central warehouse in Germany, see the shopping basket for more detailed information

Pneumatics catalog, online PDF, as of 2017-05-02, ©AVENTICS S.à r.l., subject to change

Piston rod cylinders ▶ Standard cylinders

ISO 15552, Series PRA
 Accessories

Part No.	Piston Ø	For series	ØAB	AO	AT	AU ±0,2	Ød	E	L1	L2
1827001272	40	ICL CCI CCL-IC/-IS PRA/TRB CVI	10	10	4 ±0,3	28	6.6	56	26	17
1827001273	50	ICL CCI CCL-IC/-IS PRA/TRB CVI	10	11	5 ±0,3	32	9	68	32	21.5
1827001498	63	ICL CCI CCL-IC/-IS PRA/TRB CVI	10	13	5 ±0,3	32	9	78	34	21.5
1827001275	80	ICL CCI CCL-IC/-IS PRA/TRB CVI	12	16	6 ±0,5	41	11	98	47	27
1827001276	100	ICL CCI CCL-IC/-IS PRA/TRB CVI	14.5	19	6 ±0,5	41	11	117	52	26.5
1827001310	125	ICL PRA TRB CCL-IS CVI	16.5	20	8 ±1,0	45	13.5	144	69	35

Part No.	Piston Ø	R	TG	TR	Standardiza- tion					
1827001271	32	15	32,5 ±0,2	32	ISO 15552					
1827001272	40	17.5	38 ±0,2	36	ISO 15552					
1827001273	50	20	46,5 ±0,2	45	ISO 15552					
1827001498	63	22.5	56,5 ±0,2	50	ISO 15552					
1827001275	80	22.5	72 ±0,2	63	ISO 15552					
1827001276	100	27.5	89 ±0,2	75	ISO 15552					
1827001310	125	30	110 ±0,3	90	ISO 15552					

Material: Steel
 Surface: galvanized

Bolts, AA4



00105158

Fig. 1

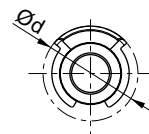
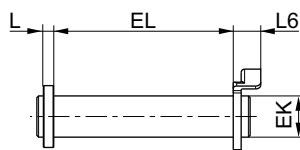
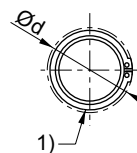

Fig. 2



21294

Scope of delivery: pivot pins incl. circlips
1) circlip DIN 471

Part No.	Piston Ø	Ø d 2)	EK e8	EL	L 2)	L6 2)	Standardiza- tion	Weight [kg]	Fig.
1823120020	32	20	10	45,2 +0,3	3.5	9	-	0.03	Fig. 1
1823120021	40	22	12	52,2 +0,3	4	9	-	0.05	Fig. 1
1823120022	50	22	12	60,2 +0,3	4	9	-	0.06	Fig. 1
1823120023	63	28	16	70,2 +0,3	4.5	11	-	0.12	Fig. 1
1823120024	80	28	16	90,2 +0,3	4.5	11	-	0.15	Fig. 1
1823120025	100	38	20	110,2 +0,3	5	11	-	0.29	Fig. 1
5236000092	125	34.2	25	132 +0,5	-	3,75	ISO 15552	0.53	Fig. 2

2) Max.
Material: Steel
Surface: galvanized

Piston rod cylinders ▶ Standard cylinders

ISO 1552, Series PRA
Accessories

Nut for piston rod, Series MR9



00105168

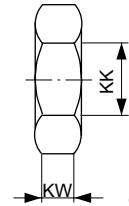
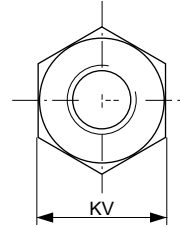

00105192

Part No.	KK	KV	KW	Material	Surface	Weight [kg]				
1823300020	M10x1,25	17	6	Steel	galvanized	0.01				
8103190344	M12x1,25	19	6	Steel	galvanized	0.012				
1823300030	M16x1,5	24	8	Steel	galvanized	0.017				
1823300031	M20x1,5	30	10	Steel	galvanized	0.03				
1823A00029	M27x2	41	13.5	Steel	galvanized	0.108				
8103190414	M36x2	55	18	Steel	galvanized	0.175				
8103190424	M42x2	65	21	Steel	galvanized	0.37				

Rod clevis, Series AP2
▶ galvanized steel



00105171

Fig. 1

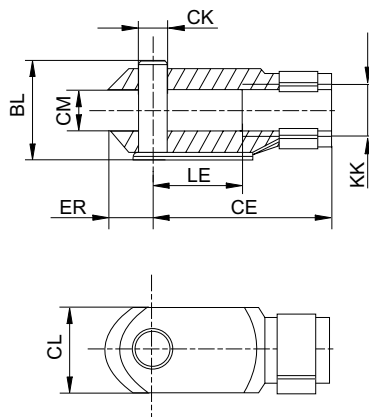
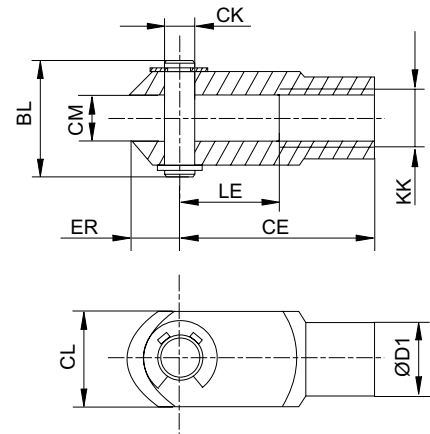

Fig. 2



00126410

Part No.	KK	BL	CE	ØCK e11	CL	CM	ØD1	ER	LE	Material
1822122024	M10x1,25	26	40	10	20	10	18	12	20	Steel
1822122025	M12x1,25	31	48	12	24	12	20	14	24	Steel
1822122005	M16x1,5	39	64	16	32	16	26	19	32	Steel
1822122004	M20x1,5	50	80	20	40	20	34	20	40	Steel
1827001493	M27x2	68	110	30	55	30	48	38	54	Steel

ISO 1552, Series PRA

Accessories

Part No.	Surface	Weight [kg]	Fig.								
1822122024	galvanized	0.1	Fig. 1								
1822122025	galvanized	0.16	Fig. 1								
1822122005	galvanized	0.4	Fig. 1								
1822122004	galvanized	0.7	Fig. 1								
1827001493	galvanized	2	Fig. 2								

Rod clevis, Series PM6

▶ galvanized steel



00105173

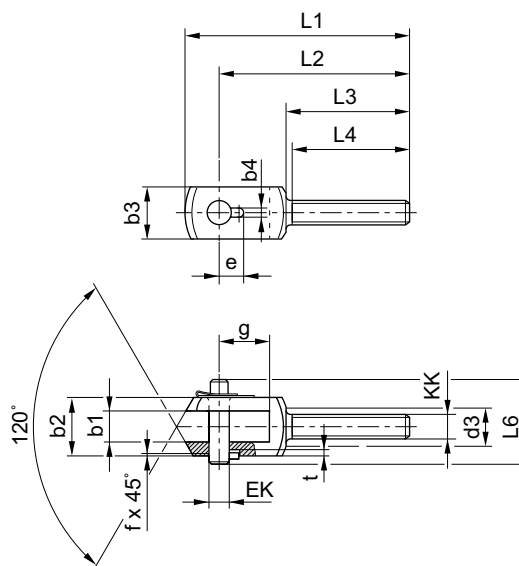

00105197

Scope of delivery incl. bolt

Part No.	KK	b1 B12	b2 d12	b3	b4 +0,2	d3	e +0,3	EK	f	g	L1	L2
1822122032	M10x1,25	14	28	20	3.3	17	11.5	10	0.7	20	90	78
1822122033	M12x1,25	16	30	25	4.3	19	12	12	1	26	108	92
1822122034	M16x1,5	21	40	35	4.3	24	14	16	1	31	129	108
1822122035	M20x1,5	25	50	40	4.3	30	16	20	1	43	156	131
1822122036	M27x2	37	67	60	6.3	38	24	30	1.5	54	200	168

Part No.	L3	L4 +1	L6	t +0,2	Material	Surface						
1822122032	53	50	35	3	Steel	galvanized						
1822122033	58	55	39	3	Steel	galvanized						
1822122034	65	62	50	3	Steel	galvanized						
1822122035	73	69	60	3	Steel	galvanized						
1822122036	98	92	77	5	Steel	galvanized						

Piston rod cylinders ▶ Standard cylinders

ISO 1552, Series PRA
 Accessories

Ball eye rod end with flange, Series AP6
 ▶ galvanized steel

00105172

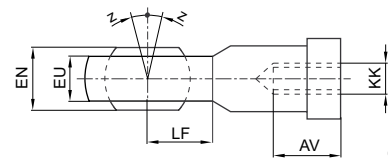
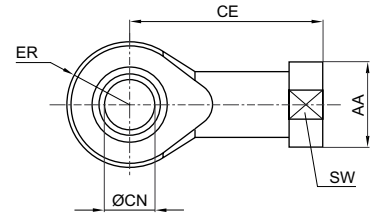

00126602

Part No.	KK	AA	AV min.	CE	Ø CN H7	EN -0,1	ER	EU max.	LF	SW	Z [°] max.
1822124003	M10x1,25	19	15	43	10	14	14	11.5	14	17	4
1822124004	M12x1,25	22	18	50	12	16	16	12.5	16	19	4
1822124005	M16x1,5	27	24	64	16	21	21	15.5	21	22	4
1822124006	M20x1,5	34	30	77	20	25	25	18.5	25	30	4
1822124013	M27x2	50	45	110	30	37	35	27	35	41	4

Part No.	Material	Surface	Weight [kg]
1822124003	Steel	galvanized	0.07
1822124004	Steel	galvanized	0.12
1822124005	Steel	galvanized	0.21
1822124006	Steel	galvanized	0.38
1822124013	Steel	galvanized	1.17

Flexible spherical coupling, Series PM5

00105169

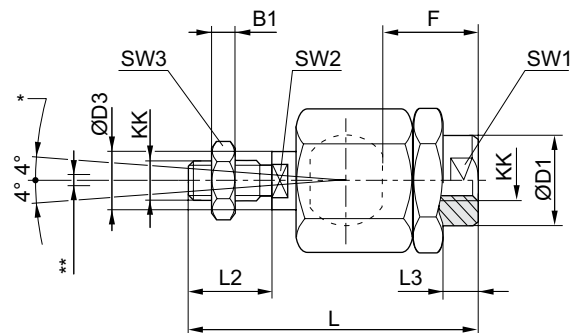
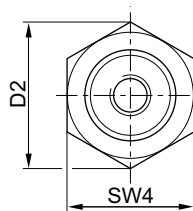

D900_029

* Angle joint
 ** Radial joint from 0,5 - 2 mm
 Axial play set to 0.05 to 0.2 mm

ISO 1552, Series PRA
 Accessories

Part No.	KK	B1	Ø D1	D2	Ø D3	F	L ±2	L2	L3 ±1	SW1	SW2	SW3
1826409002	M10x1,25	6	21.5	34	14	23	73	20	7.5	19	12	17
1826409003	M12x1,25	7	21.5	34	14	28	77	24	13	19	12	19
1826409004	M16x1,5	8	33.5	47	22	32	108	32	9	30	19	24
1826409005	M20x1,5	10	33.5	47	22	42	122	40	19	30	19	30
1826409006	M27x2	13.5	62	62	28	48	147	54	14	32	24	41

Part No.	SW4	Material	Surface	Weight
				[kg]
1826409002	30	Steel	galvanized	0.21
1826409003	30	Steel	galvanized	0.21
1826409004	41	Steel	galvanized	0.65
1826409005	41	Steel	galvanized	0.68
1826409006	55	Steel	galvanized	1.7

Flexible plate coupling, Series PM7

00105170

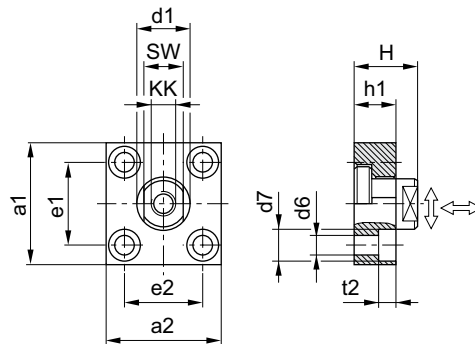

00105194

Part No.	KK	a1	a2	d1 h11	d6 H13	d7 H13	e1 H13	e2	h1	t2	H
1827001629	M10x1,25	60	37	20	6.6	11	36 ±0,15	23 ±0,15	15	7	24
1827001630	M12x1,25	60	56	25	9	15	42 ±0,2	38 ±0,2	20	9	30
1827001631	M16x1,5	80	80	30	11	18	58 ±0,2	58 ±0,2	20	11	32
1827001632	M20x1,5	90	90	40	14	20	65 ±0,3	65 ±0,3	20	13	35
1827001633	M27x2	90	90	40	14	20	65 ±0,3	65 ±0,3	20	13	35
1827001634	M36x2	125	125	60	18	26	90 ±0,3	90 ±0,3	30	17	55

Part No.	SW	Tightening torque for the coupling pin Ma ± 5%	Axial play	Radial play	Material	Surface	Weight
		[Nm]	[min./max.]	[min./max.]			[kg]
1827001629	17	17	0.4 - 0.8	1.9 - 2.3	Steel	galvanized	0.3
1827001630	19	29	0.4 - 0.8	1.9 - 2.3	Steel	galvanized	0.4
1827001631	24	71	0.4 - 0.8	1.9 - 2.3	Steel	galvanized	0.9
1827001632	36	138	0.4 - 0.8	1.9 - 2.3	Steel	galvanized	1.15
1827001633	36	350	0.4 - 0.8	1.9 - 2.3	Steel	galvanized	1.1
1827001634	50	1080	0.4 - 0.95	2.8 - 3.4	Steel	galvanized	3.4

Piston rod cylinders ▶ Standard cylinders

ISO 15552, Series PRA Accessories

Series MSS

▶ Für Serie: PRA, TRB (Ø 32 - 125 mm)



Operating pressure 2 bar / 10 bar
 Medium Compressed air
 Oil content of compressed air 0 mg/m³ / 5 mg/m³

Materials:
 Housing Aluminum, anodized

20908

Piston Ø	Seal	Scraper	Ambient temperature min./max.	Application area	Part No.
32	Acrylonitrile butadiene rubber	Polyester elastomer	-20°C / +80°C	1)	0496400704
	Acrylonitrile butadiene rubber	Polytetrafluorethylene	-20°C / +80°C	2)	0496401107
	Fluorocautchouc	Polytetrafluorethylene	-10°C / +120°C	3)	0496401700
40	Acrylonitrile butadiene rubber	Brass	-20°C / +80°C	2)	0496400402
	Fluorocautchouc	Brass	-10°C / +120°C	2)	0496401409
	Acrylonitrile butadiene rubber	Polyester elastomer	-20°C / +80°C	1)	0496400801
	Acrylonitrile butadiene rubber	Polytetrafluorethylene	-20°C / +80°C	3)	0496401204
	Fluorocautchouc	Polytetrafluorethylene	-10°C / +120°C	3)	0496401808
50, 63	Acrylonitrile butadiene rubber	Brass	-20°C / +80°C	2)	0496400518
	Fluorocautchouc	Brass	-10°C / +120°C	2)	0496401506
	Acrylonitrile butadiene rubber	Polyester elastomer	-20°C / +80°C	1)	0496400909
	Acrylonitrile butadiene rubber	Polytetrafluorethylene	-20°C / +80°C	3)	0496402103
	Fluorocautchouc	Polytetrafluorethylene	-10°C / +120°C	3)	0496401905
80, 100	Acrylonitrile butadiene rubber	Brass	-20°C / +80°C	2)	0496400607
	Fluorocautchouc	Brass	-10°C / +120°C	2)	0496401603
	Acrylonitrile butadiene rubber	Polyester elastomer	-20°C / +80°C	1)	0496401018
	Acrylonitrile butadiene rubber	Polytetrafluorethylene	-20°C / +80°C	3)	0496402200
	Fluorocautchouc	Polytetrafluorethylene	-10°C / +120°C	3)	0496402006
125	Acrylonitrile butadiene rubber	Brass	-20°C / +80°C	2)	0496301404
	Fluorocautchouc	Brass	-10°C / +120°C	2)	0496303105
	Acrylonitrile butadiene rubber	Polyester elastomer	-20°C / +80°C	1)	0496301307
	Acrylonitrile butadiene rubber	Polytetrafluorethylene	-20°C / +80°C	3)	0496301706
	Fluorocautchouc	Polytetrafluorethylene	-10°C / +120°C	3)	0496303202

1) Paper/printing industry / Textile industry

2) Chemical industry / Sugar production / Steel production / Automotive industry / Woodworking industry

3) Textile industry / Food industry / Chemical industry / Sugar production

ISO 15552, Series PRA
 Accessories

For cylinder diameters: 32-40 mm

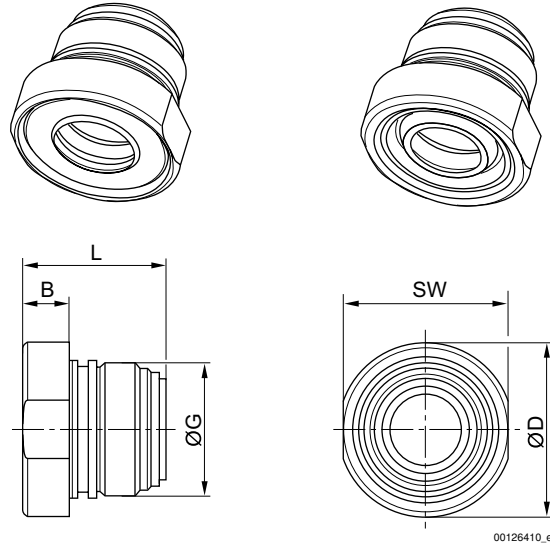

For cylinder diameters: 50-125 mm

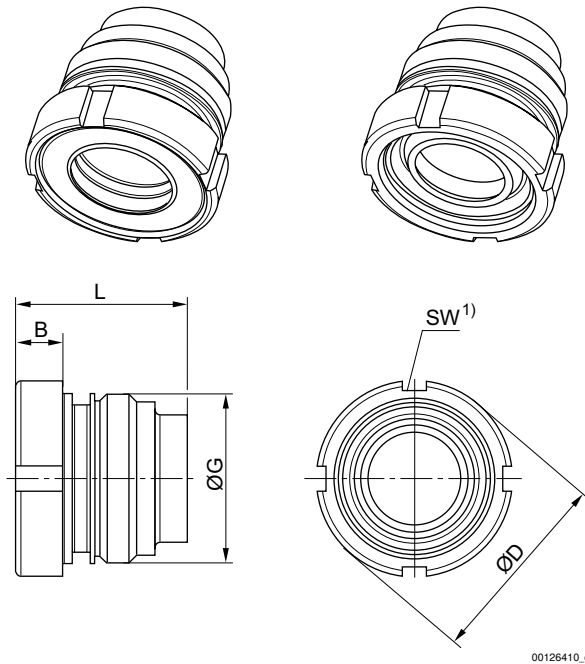

1) Can be mounted with hook wrench in accordance with DIN 1810 A

Piston rod cylinders ▶ Standard cylinders

ISO 1552, Series PRA
Accessories

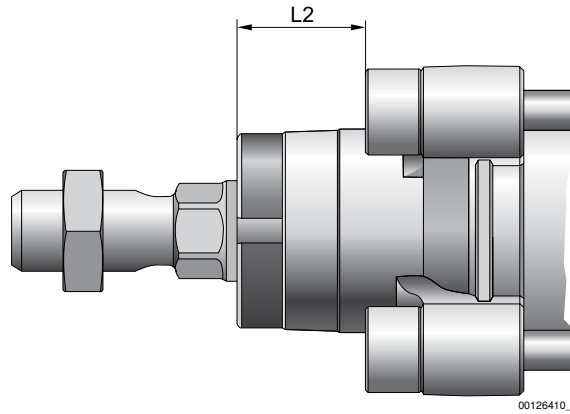

Part No.	Ø	B	ØD	G	L	L2	SW					
0496400704	32	6.7	24.5	M22x1	23	16.25	23					
0496401107	32	6.7	24.5	M22x1	23	16.25	23					
0496401700	32	6.7	24.5	M22x1	23	16.25	23					
0496400402	40	9.2	34	M26x1,5	28.1	18.25	32					
0496401409	40	9.2	34	M26x1,5	28.1	18.25	32					
0496400801	40	9.2	34	M26x1,5	28.1	18.25	32					
0496401204	40	9.2	34	M26x1,5	28.1	18.25	32					
0496401808	40	9.2	34	M26x1,5	28.1	18.25	32					
0496400518	50, 63	9	38.5	M33x2	33.5	25	40-42					
0496401506	50, 63	9	38.5	M33x2	33.5	25	40-42					
0496400909	50, 63	9	38.5	M33x2	33.5	25	40-42					
0496402103	50, 63	9	38.5	M33x2	33.5	25	40-42					
0496401905	50, 63	9	38.5	M33x2	33.5	25	40-42					
0496400607	80, 100	10	44	M40x2	44	33	45-50					
0496401603	80, 100	10	44	M40x2	44	33	45-50					
0496401018	80, 100	10	44	M40x2	44	33	45-50					
0496402200	80, 100	10	44	M40x2	44	33	45-50					
0496402006	80, 100	10	44	M40x2	44	33	45-50					
0496301404	125	12	57	M50x2	56	45	58-62					
0496303105	125	12	57	M50x2	56	45	58-62					
0496301307	125	12	57	M50x2	56	45	58-62					
0496301706	125	12	57	M50x2	56	45	58-62					
0496303202	125	12	57	M50x2	56	45	58-62					

ISO 15552, Series PRA Accessories

Guide unit, Series GU1

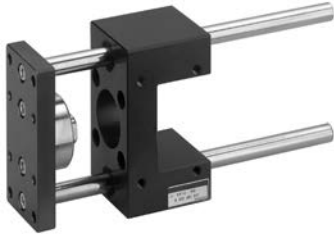

00105859

Bearing type Plain bearing
 Ambient temperature min./max. -20 °C / 80 °C
 For standard cylinders ISO 15552

Materials:
 Bearing housings Aluminum, colorless anodized
 Bearing type Sintered bronze
 Carrying plate Aluminum, colorless anodized
 Flexible coupling in carrying plate Stainless steel
 Guide rods Stainless steel, smooth rolled

Suitable piston Ø		[mm]	32	40	50	63	80
Weight	0 mm stroke	[kg]	0.63	0.946	1.356	1.655	3.45
	10 mm stroke	[kg]	0.0122	0.0176	0.0176	0.0176	0.0222

Suitable piston Ø		[mm]	100				
Weight	0 mm stroke	[kg]	4.69				
	10 mm stroke	[kg]	0.0222				

	Suitable piston Ø [mm]	32	40	50	63	80	
	Stroke 50	0821401010	0821401020	0821401030	0821401480	0821401050	
	100	0821401011	0821401021	0821401031	0821401481	0821401051	
	160	0821401012	0821401022	0821401032	0821401482	0821401052	
	200	0821401013	0821401023	0821401033	0821401483	0821401053	
	250	0821401014	0821401024	0821401034	0821401484	0821401054	
	320	0821401015	0821401025	0821401035	0821401485	0821401055	
	400	0821401016	0821401026	0821401036	0821401486	0821401056	
	500	0821401017	0821401027	0821401037	0821401487	0821401057	
	600	0821401018	0821401028	0821401038	0821401488	0821401058	
	800	0821401019	0821401029	0821401039	0821401489	0821401059	
	1000	0821401500	0821401502	0821401504	0821401490	0821401508	
	1200	0821401501	0821401503	0821401505	0821401491	0821401509	
		Suitable piston Ø [mm]	100				
		Stroke 50	0821401060				
100		0821401061					
160		0821401062					
200		0821401063					
250		0821401064					
320		0821401065					
400		0821401066					
500		0821401067					
600		0821401068					
800		0821401069					
1000	0821401510						
1200	0821401511						

Inch dimensions rounded to the nearest whole number.
 For use with hybrid inch cylinders with metric piston rod thread

Piston rod cylinders ▶ Standard cylinders

ISO 1552, Series PRA Accessories

Ø 32 - 100 mm

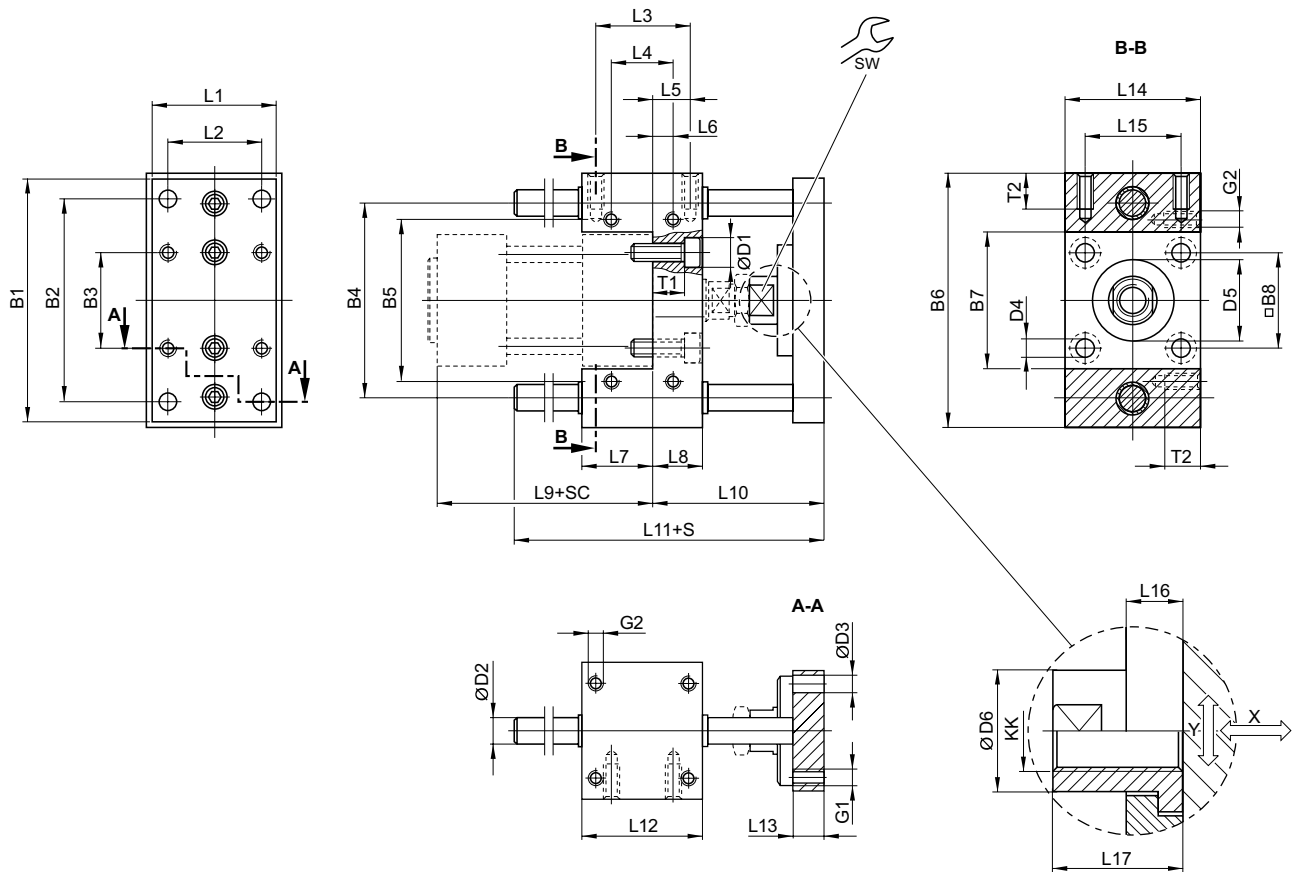

00127778

S = stroke
 SC = cylinder stroke
 X = max. play (axial)
 Y = min. play (radial)

[Piston Ø]	B1	B2	B3	B4	B5	B6	B7	B8	D1	D2	D3	D4	D5
32	90	78	32.5	74	58	100	48	32.5	11	10	6.6	6.6	30 M8
40	100	84	38	80	64	106	54	38	11	12	6.6	6.6	35 M8
50	120	100	46.5	96	80	125	66	46.5	15	12	9	9	40 M8
63	125	105	56.5	104	95	132	76	56.5	15	12	9	9	45 M8
80	155	130	72	130	130	165	98	72	18	16	11	11	45 M8
100	175	150	89	150	150	185	118	89	18	16	11	11	55 M8

[Piston Ø]	D6	G1	G2	KK	L1	L2	L3	L4	L5	L6	L7	L8	L9
32	18	M6	M6	M10x1,25	45	32.5	32.5	32.5	9.25	9.25	31	17	94
40	18	M6	M6	M12x1,25	50	38	38	38	11	11	37	21	105
50	24	M8	M8	M16x1,5	60	46.5	46.5	46.5	18.75	18.75	34	25	106
63	24	M8	M8	M16x1,5	70	56.5	56.5	56.5	15.25	15.25	51	25	121
80	30	M10	M10	M20x1,5	90	72	72	50	25	14	56	34	128
100	30	M10	M10	M20x1,5	110	89	89	70	28.5	19	71	39	138

[Piston Ø]	L10	L11	L12	L13	L14	L15	L16	L17	SW	T1	T2		
32	69	106	48	12	48	32.5	14	22	15	10	14		

Part numbers marked in bold are available from the central warehouse in Germany, see the shopping basket for more detailed information

Pneumatics catalog, online PDF, as of 2017-05-02, ©AVENTICS S.à r.l., subject to change

ISO 15552, Series PRA Accessories

[Piston Ø]	L10	L11	L12	L13	L14	L15	L16	L17	SW	T1	T2		
40	74	117	58	12	56	38	14	22	15	14	14		
50	89	129	59	15	66	46.5	14	26	22	16	16		
63	89	146	76	15	76	56.5	14	26	22	16	16		
80	106	170	90	16	98	72	14	32	27	24	20		
100	111	190	110	16	118	89	14	32	27	29	20		

Useful load

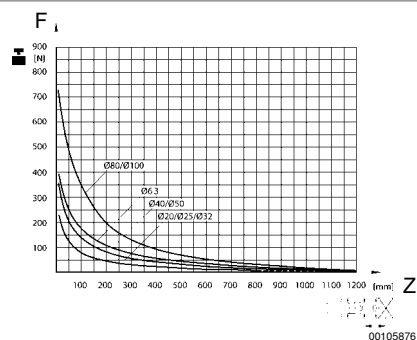
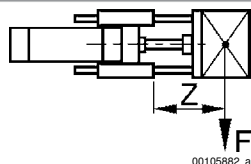

F = Useful load, Z = Projection

Guide unit, Series GH2



Bearing type
Ambient temperature min./max.
For standard cylinders

Materials:
Bearing type
Carrying plate
Flexible coupling in carrying plate
Guide rods

Linear ball bearing
-20 °C / 80 °C
ISO 15552

Steel
Aluminum, colorless anodized
Stainless steel
Steel, hardened

Suitable piston Ø		[mm]	32	40	50	63	80
Weight	0 mm stroke	[kg]	1.3	2.3	3.7	4.7	8.8
	10 mm stroke	[kg]	0.009	0.016	0.025	0.025	0.039

Suitable piston Ø		[mm]	100				
Weight	0 mm stroke	[kg]	11.1				
	10 mm stroke	[kg]	0.039				

Part numbers marked in bold are available from the central warehouse in Germany, see the shopping basket for more detailed information

Pneumatics catalog, online PDF, as of 2017-05-02, ©AVENTICS S.à r.l., subject to change

Piston rod cylinders ▶ Standard cylinders

ISO 1552, Series PRA
 Accessories

	Suitable piston Ø [mm]	32	40	50	63	80
	Stroke 50	0821401320	0821401330	0821401340	0821401380	-
	100	0821401321	0821401331	0821401341	0821401381	0821401360
	200	0821401322	0821401332	0821401342	0821401382	0821401361
	320	0821401323	0821401333	0821401343	0821401383	0821401362
	500	0821401324	0821401334	0821401344	0821401384	0821401363
	600	0821401325	0821401335	0821401345	0821401385	0821401364
	800	0821401326	0821401336	0821401346	0821401386	0821401365
	1000	0821401327	0821401337	0821401347	0821401387	0821401366
	1200	0821401328	0821401338	0821401348	0821401388	0821401367
	Suitable piston Ø [mm]	100				
	Stroke 50	-				
	100	0821401370				
	200	0821401371				
	320	0821401372				
	500	0821401373				
	600	0821401374				
	800	0821401375				
	1000	0821401376				
	1200	0821401377				

Inch dimensions rounded to the nearest whole number.
 For use with hybrid inch cylinders with metric piston rod thread

ISO 15552, Series PRA

Accessories

Ø 32 - 100 mm

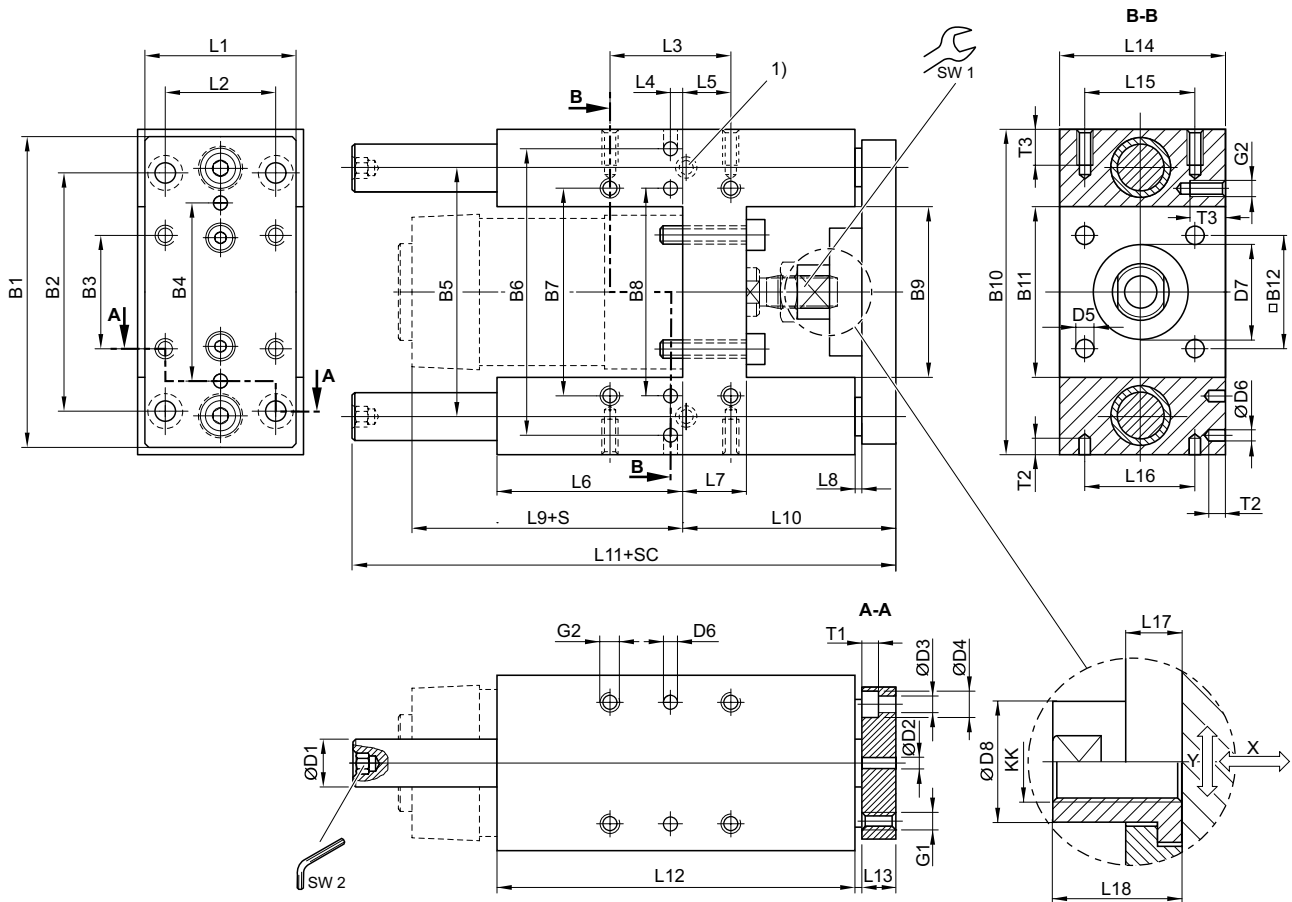

00127779

- 1) Lube nipple
 S = stroke
 SC = cylinder stroke
 X = max. play (axial)
 Y = min. play (radial)
 Hexagon in guide rod

[Piston Ø]	B1	B2	B3	B4	B5	B6	B7	B8	B9	B10	B11	B12	D1
32	90	78	32.5	50	74	81	61	61	50.2	97	50.2	32.5	12
40	110	84	38	54	87	99	69	69	58.2	115	58.2	38	16
50	130	100	46.5	72	104	119	85	85	70.2	137	70.2	46.5	20
63	145	105	56.5	82	119	132	100	100	85.2	152	85.2	56.5	20
80	180	130	72	106	148	166	130	130	105.4	189	105.4	72	25
100	200	150	89	131	172	190	150	150	130.4	213	130.4	89	25

[Piston Ø]	D2 H7	D3	D4	D5	D6 H7	D7 M8	D8	G1	G2	KK	L1	L2	L3
32	6	6.6	11	6.6	6	30	14.5	M6	M6	M10x1,25	45	32.5	32.5
40	6	6.6	11	6.6	6	35	18	M6	M6	M12x1,25	54	38	38
50	6	9	15	9	6	40	24	M8	M8	M16x1,5	63	46.5	46.5
63	6	9	15	9	6	45	24	M8	M8	M16x1,5	80	56.5	56.5
80	6	11	18	11	6	45	30	M10	M10	M20x1,5	100	72	72
100	6	11	18	11	6	55	30	M10	M10	M20x1,5	120	89	89

Part numbers marked in bold are available from the central warehouse in Germany, see the shopping basket for more detailed information

Pneumatics catalog, online PDF, as of 2017-05-02, ©AVENTICS S.à r.l., subject to change

Piston rod cylinders ▶ Standard cylinders

ISO 15552, Series PRA Accessories

[Piston Ø]	L4	L5	L6	L7	L8	L9	L10	L11	L12	L13	L14	L15	L16
32	12	4.25	76	17	3	94	64	177.5	125	12	50	32.5	32.5
40	8	11	81	21	3	105	74	192.5	140	12	58	38	38
50	4.5	18.75	79	26	3	106	89	237	150	15	70	46.5	46.5
63	13	15.25	111	26	3	121	89	237	182	15	85	56.5	56.5
80	15	21	128	34	3	128	110	280	215	20	105	72	72
100	20	24.5	128	39	3	138	115	280	220	20	130	89	89

[Piston Ø]	L17	L18	T1	T2	T3	SW1	SW2						
32	6	17	6.5	10	15	13	5						
40	14	22	6.5	10	15	15	6						
50	14	26	9	10	16	22	6						
63	14	26	9	10	16	22	6						
80	14	32	11	10	20	27	8						
100	14	32	11	10	20	27	8						

Useful load

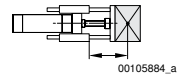
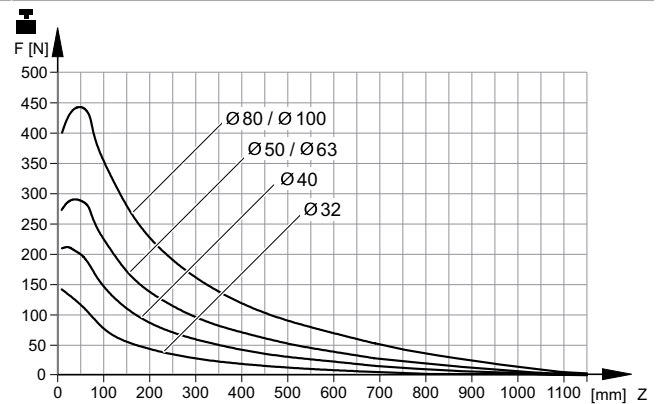
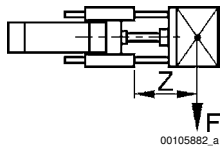

Service life 2×10^6 m
F = Useful load, Z = Projection

ISO 15552, Series PRA
Accessories

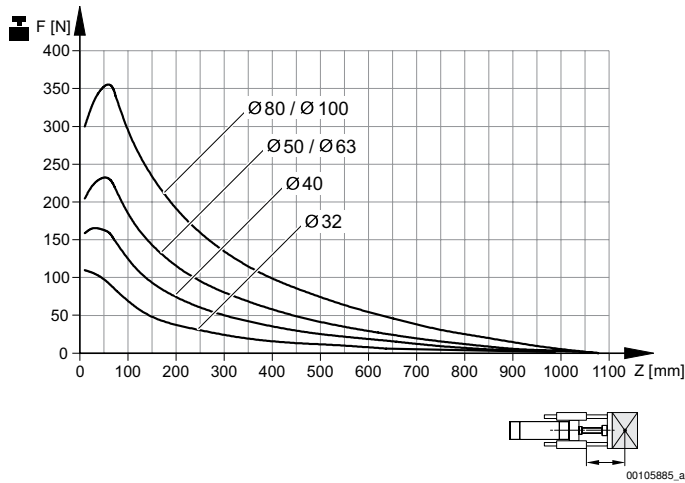

Service life 5×10^6 m
F = Useful load, Z = Projection

Reduction of useful load for short-stroke

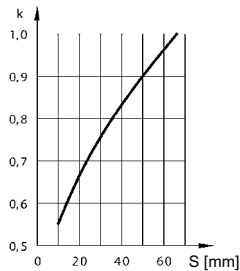

S = stroke
k=correction factor: normal=1; shock loaded=2
With a short stroke, the useful load figures determined from the diagram must be multiplied by the correction factor k. These short-stroke adjustments are already included in the load diagram for a displacement of up to 60 mm.

Bending due to own load

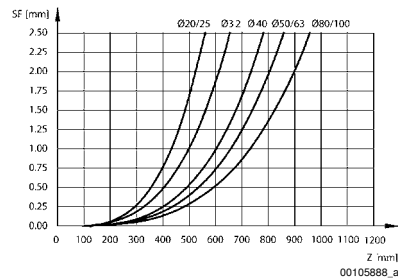
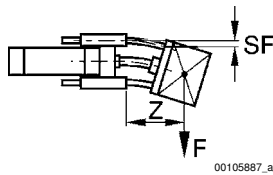

F = useful load (at the load center), SF = bending, Z = projection

Piston rod cylinders ▶ Standard cylinders

ISO 1552, Series PRA
Accessories

Bending due to 10 N load

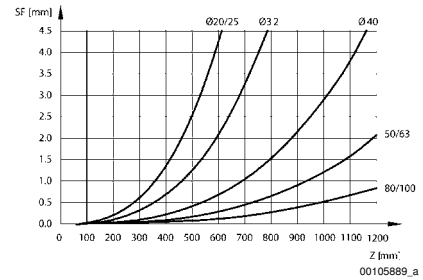
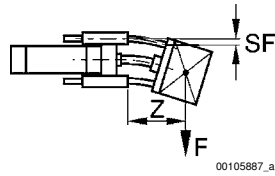

F = useful load (at the load center), SF = bending, Z = projection

Guide unit, Series GH1



00105863

Bearing type
Ambient temperature min./max.
For standard cylinders

Plain bearing
-20 °C / 80 °C
ISO 15552

Materials:
Bearing housings
Bearing type
Carrying plate
Flexible coupling in carrying plate
Guide rods

Aluminum, colorless anodized
Sintered bronze
Aluminum, colorless anodized
Stainless steel
Stainless steel, smooth rolled

Suitable piston Ø		[mm]	32	40	50	63	80
Weight	0 mm stroke	[kg]	1.3	2.3	3.7	4.7	8.8
	10 mm stroke	[kg]	0.009	0.016	0.025	0.025	0.039

Suitable piston Ø		[mm]	100				
Weight	0 mm stroke	[kg]	11.1				
	10 mm stroke	[kg]	0.039				

ISO 15552, Series PRA
 Accessories

	Suitable piston Ø [mm]	32	40	50	63	80
	Stroke 50	0821401220	0821401230	0821401240	0821401280	-
	100	0821401221	0821401231	0821401241	0821401281	0821401260
	160	0821401222	0821401232	0821401242	0821401285	-
	200	0821401223	0821401233	0821401243	0821401282	0821401261
	250	0821401224	0821401234	0821401244	0821401286	-
	320	0821401225	0821401235	0821401245	0821401283	0821401262
	400	0821401226	0821401236	0821401246	0821401287	-
	500	0821401227	0821401237	0821401247	0821401284	0821401263
	600	0821401228	0821401238	0821401249	0821401288	0821401264
	800	0821401229	0821401239	0821401474	0821401289	0821401265
	1000	0821401470	0821401472	0821401475	0821401290	0821401266
	1200	0821401471	0821401473	0821401476	0821401291	0821401267
	Suitable piston Ø [mm]	100				
	Stroke 50	-				
	100	0821401270				
	160	-				
	200	0821401271				
	250	-				
	320	0821401272				
	400	-				
	500	0821401273				
	600	0821401274				
	800	0821401275				
	1000	0821401276				
	1200	0821401277				

Inch dimensions rounded to the nearest whole number.
 For use with hybrid inch cylinders with metric piston rod thread

Piston rod cylinders ▶ Standard cylinders

ISO 15552, Series PRA
Accessories

Ø 32 - 100 mm

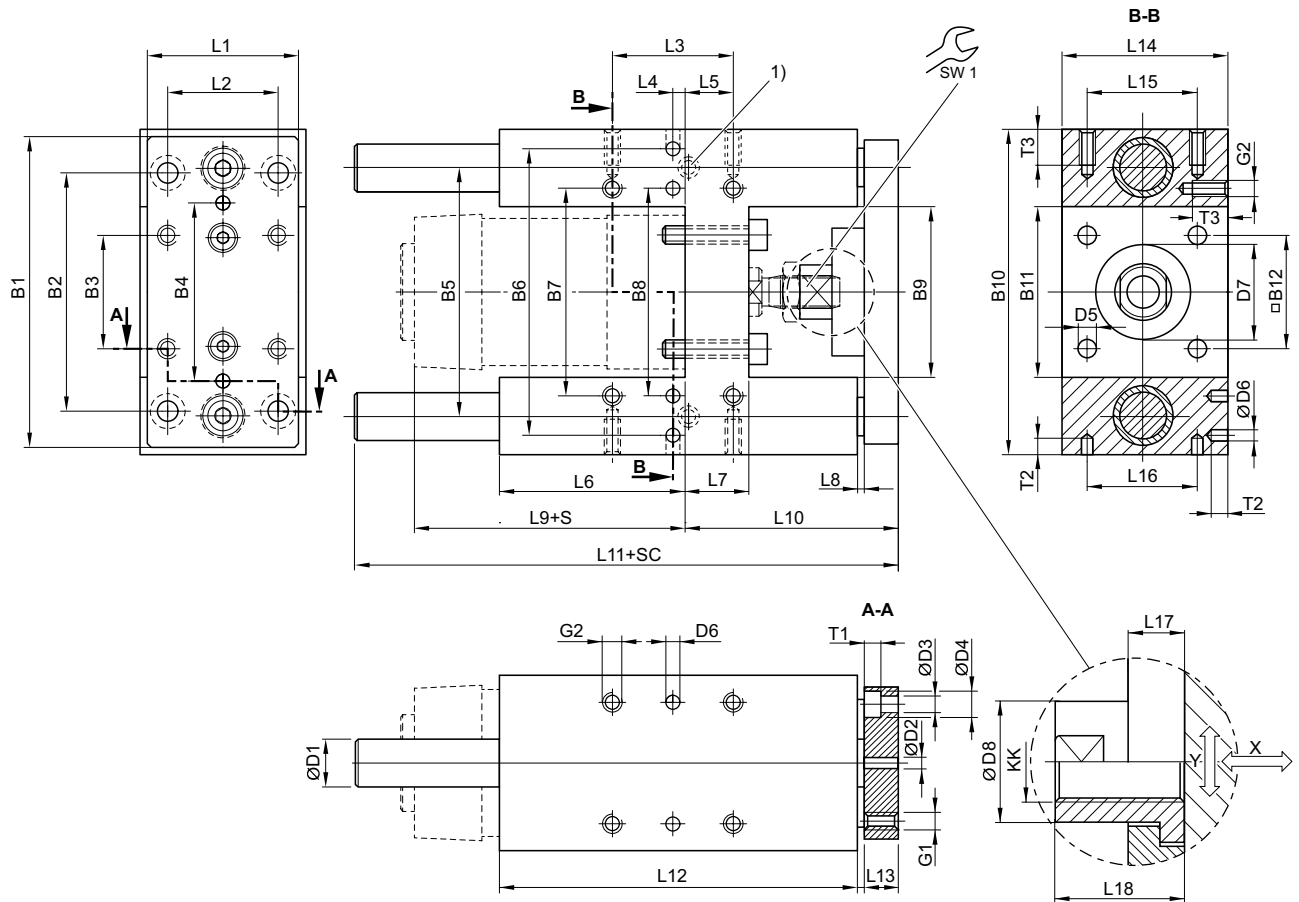

- 1) Lube nipple
- S = stroke
- SC = cylinder stroke
- X = max. play (axial)
- Y = min. play (radial)

00127787

[Piston Ø]	B1	B2	B3	B4	B5	B6	B7	B8	B9	B10	B11	B12	D1
32	90	78	32.5	50	74	81	61	61	50.2	97	50.2	32.5	12
40	110	84	38	54	87	99	69	69	58.2	115	58.2	38	16
50	130	100	46.5	72	104	119	85	85	70.2	137	70.2	46.5	20
63	145	105	56.5	82	119	132	100	100	85.2	152	85.2	56.5	20
80	180	130	72	106	148	166	130	130	105.4	189	105.4	72	25
100	200	150	89	131	172	190	150	150	130.4	213	130.4	89	25

[Piston Ø]	D2 H7	D3	D4	D5	D6 H7	D7 M8	D8	G1	G2	KK	L1	L2	L3
32	6	6.6	11	6.6	6	30	14.5	M6	M6	M10x1,25	45	32.5	32.5
40	6	6.6	11	6.6	6	35	18	M6	M6	M12x1,25	54	38	38
50	6	9	15	9	6	40	24	M8	M8	M16x1,5	63	46.5	46.5
63	6	9	15	9	6	45	24	M8	M8	M16x1,5	80	56.5	56.5
80	6	11	18	11	6	45	30	M10	M10	M20x1,5	100	72	72
100	6	11	18	11	6	55	30	M10	M10	M20x1,5	120	89	89

Part numbers marked in bold are available from the central warehouse in Germany, see the shopping basket for more detailed information

Pneumatics catalog, online PDF, as of 2017-05-02, ©AVENTICS S.à r.l., subject to change

ISO 15552, Series PRA
Accessories

[Piston Ø]	L4	L5	L6	L7	L8	L9	L10	L11	L12	L13	L14	L15	L16
32	12	4.25	76	17	3	94	64	177.5	125	12	50	32.5	32.5
40	8	11	81	21	3	105	74	192.5	140	12	58	38	38
50	4.5	18.75	79	26	3	106	89	205	150	15	70	46.5	46.5
63	13	15.25	111	26	3	121	89	237	182	15	85	56.5	56.5
80	15	21	128	34	3	128	110	280	215	20	105	72	72
100	20	24.5	128	39	3	138	115	280	220	20	130	89	89

[Piston Ø]	L17	L18	T1	T2	T3	SW1							
32	6	17	6.5	10	15	13							
40	14	22	6.5	10	15	15							
50	14	26	9	10	16	22							
63	14	26	9	10	16	22							
80	14	32	11	10	20	27							
100	14	32	11	10	20	27							

Useful load

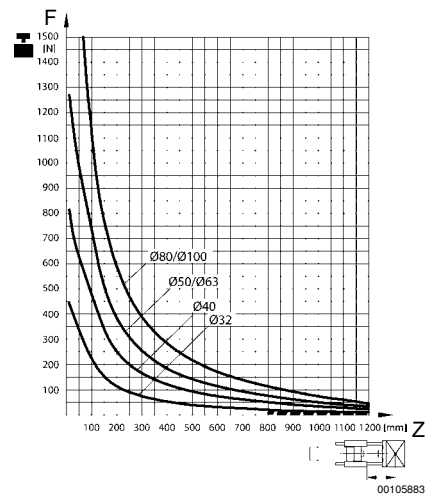
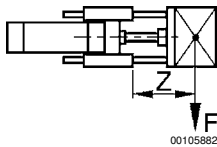

Bending due to own load

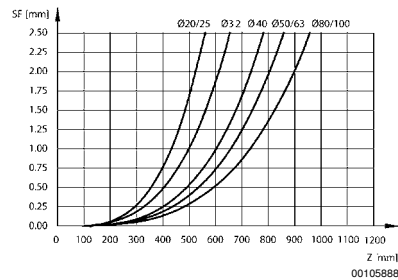
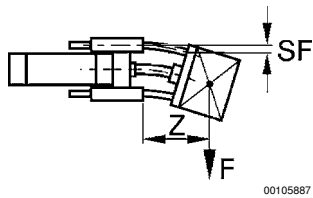

F = useful load (at the load center), SF = bending, Z = projection

Piston rod cylinders ▶ Standard cylinders

ISO 1552, Series PRA Accessories

Bending due to 10 N load

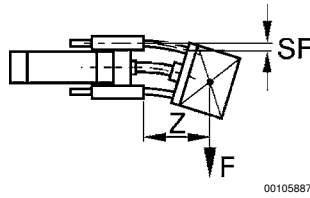

00105887

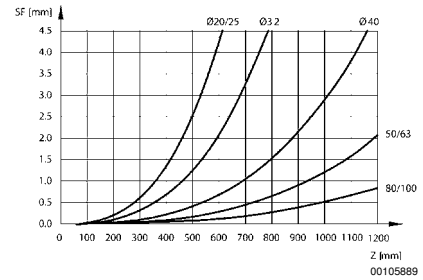

F = useful load (at the load center), SF = bending, Z = projection

Flange mounting



00106403

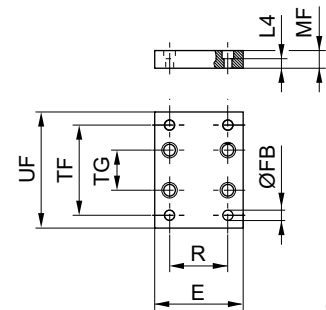

00106476

Part No.	Piston Ø	For series	E	Ø FB	L4	MF	R	TF	TG	UF
1821038079	32	for guide units H' version	50	6.6	4.5	10	32.5	116	61	130
1821038080	40	for guide units H' version	55	9	4.5	10	38	140	69	160
1821038081	50	for guide units H' version	70	9	6	12	46.5	160	85	180
1821038082	63	for guide units H' version	80	9	6	12	56.5	175	100	195
1821038083	80	for guide units H' version	100	12	9	16	72	218	130	242
1821038084	100	for guide units H' version	120	14	9	16	89	245	150	272

Material: Steel
Surface: galvanized

ISO 15552, Series PRA Accessories

Flexible coupling form B, Series GU3



00106407

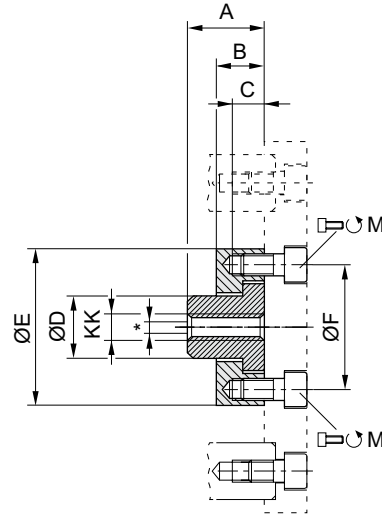

00105878_a

* Radial joint from 1,5 - 1,8 mm

Scope of delivery: flexible coupling incl. mounting screws

Part No.	KK	Ø	M	A	B	C	D	ØE	ØF	Material
R413000283	M8	20	2x M5x12	22	6	6	14.5	SW 30	26	Stainless steel
R413000284	M10x1,25	25/32	2x M5x12	17	6	6	14.5	SW 30	26	Stainless steel
R413000285	M20x1,5	80/100	4x M6x20	32	14	9.5	30	60	51	Stainless steel

for guide units

Flexible coupling form C, Series GU3



00136409

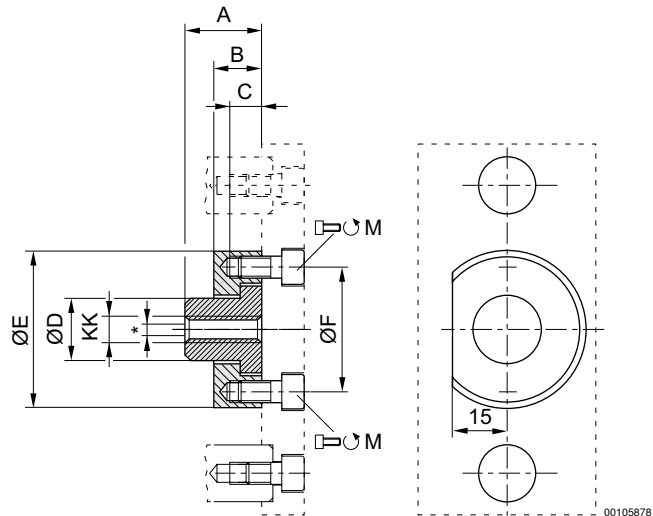

00105878

* Radial joint from 2 - 2,5 mm

Scope of delivery: flexible coupling incl. mounting screws

Piston rod cylinders ▶ Standard cylinders
**ISO 1552, Series PRA
Accessories**

Part No.	KK	Ø	M	A	B	C	D	ØE	ØF	Material
R413000276	M6	12/16	2x M4x10	18	7	7	10	22	15	Stainless steel
R413000280	M12x1,25	40	2x M6x12	22	14	8	18	45	36	Stainless steel
R413000281	M16x1,5	50/63	4x M6x14	26	14	8	24	54	45	Stainless steel
for guide units										

ISO 15552, Series PRA
 Accessories

Holding unit, Series HU1

▶ Ø32 - 100 mm ▶ hold: spring force, release: compressed air



00104762

Function	Hold with clamping jaws
Release pressure	4 bar / 8 bar
Ambient temperature min./max.	-10 °C / +60 °C
Medium temperature min./max.	-10 °C / +60 °C
Max. particle size	5 µm
Oil content of compressed air	0 mg/m ³ - 5 mg/m ³
Static holding force	See table below

Materials:	
Housing	Aluminum, black anodized

Technical Remarks

- The pressure dew point must be at least 15 °C under ambient and medium temperature and may not exceed 3 °C.
- The oil content of compressed air must remain constant during the life cycle.
- Use only the approved oils from AVENTICS, see chapter „Technical information“.
- Warning: The holding unit may not be used for the following applications: - for dynamic holding- in or as safety equipment
- Holding unit may only be unlocked when turned off.
- Make sure that the load direction does not change during a holding interval. A change in the direction of force, as well as external forces such as impacts, strong vibrations, or torsional forces, will briefly release the piston rod and may destroy the HU1 holding unit.
- When clamped, there must be no residual pressure on the holding unit (0 bar).
- Note: The minimum control pressure is \geq the working pressure of the cylinder!

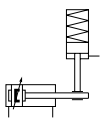
	Piston Ø	suitable piston rod Ø	Piston rod extension	Compressed air connection	Static holding force	Weight	Part No.
	[mm]	[mm]	[mm]		[N]	[kg]	
	32	12	42	M5	650	0.2	0821401165
	40	16	45	G 1/8	1100	0.27	0821401166
	50	20	57	G 1/8	1600	0.57	0821401167
	63	20	57	G 1/8	2500	0.8	0821401168
	80	25	77	G 1/8	4000	1.85	0821401169
	100	25	77	G 1/8	6300	2.9	0821401170

Holding force at 0 bar

Piston rod cylinders ▶ Standard cylinders

ISO 1552, Series PRA Accessories

Dimensions

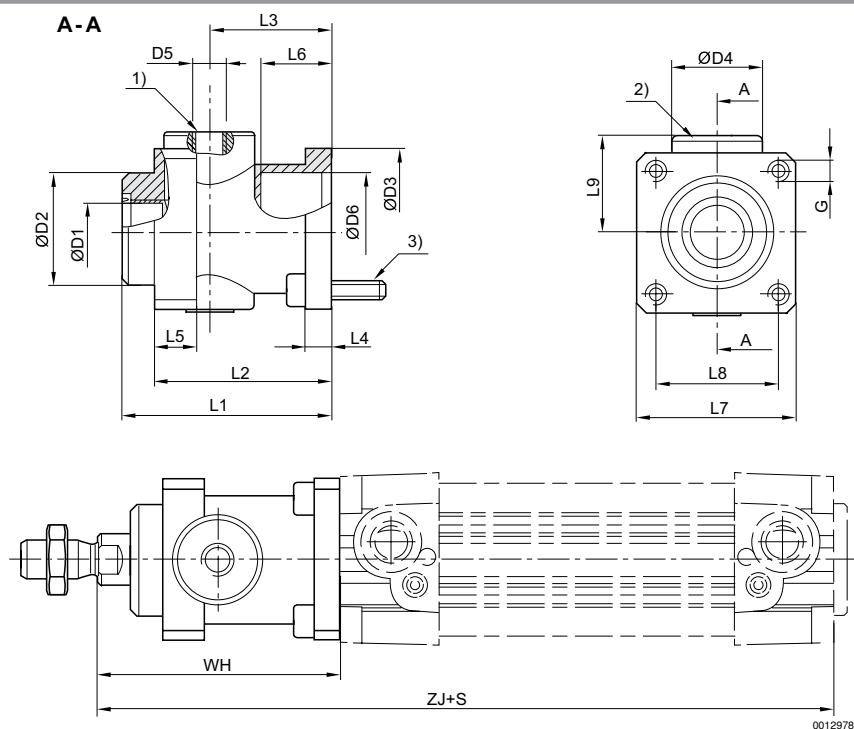

- 1) air connection
- 2) Holding cartridge
- 3) mounting screws 4x
- S = stroke

Piston Ø	Ø D1	Ø D2	Ø D3	Ø D4	D5	L1	L2	L3	L4	L5	L6	L7	L8
32	12	30	35	25	M5	58	48	34	8	13	20.5	45	32.5
40	16	35	40	28	G 1/8	65	55	38	8	13	22.5	50	38
50	20	40	50	35	G 1/8	82	70	48	15	16	29.5	60	46.5
63	20	45	60	38	G 1/8	82	70	49.5	15	16	29.5	70	56.5
80	25	45	80	48	G 1/8	110	90	61	18	20	35	90	72
100	25	55	100	58	G 1/8	115	100	69	18	20	-	105	89

Piston Ø	L9	G	WH	ZJ
32	25.5	M6	68	162
40	30	M6	75	180
50	36	M8	94	200
63	40	M8	94	215
80	50	M10	123	251
100	58	M10	128	266

ISO 15552, Series PRA Accessories

Locking unit, Series LU1

▶ Ø32 - 100 mm ▶ Hold: adjustable spring force, Release: compressed air



00136968

Function	Clamp with eccentric tappet
Release pressure	2 bar / 8 bar
Ambient temperature min./max.	-20 °C / +80 °C
Medium temperature min./max.	-20 °C / +80 °C
Max. particle size	5 µm
Oil content of compressed air	0 mg/m ³ - 5 mg/m ³
Static holding force	See table below
Materials:	
Housing	Aluminum, anodized
Cover	Die-cast aluminum

Technical Remarks

- The pressure dew point must be at least 15 °C under ambient and medium temperature and may not exceed 3 °C.
- The oil content of compressed air must remain constant during the life cycle.
- Use only the approved oils from AVENTICS, see chapter „Technical information“.
- Warning: The Locking unit may not be used for the following applications:- for dynamic holding- in or as safety equipment
- Locking unit may only be unlocked when turned off.
- Note: The minimum release pressure is \geq the working pressure of the cylinder! The holding force is dependent on the set spring force

	Piston Ø	suitable piston rod Ø	Piston rod extension	Compressed air connection	Static holding force	Weight	Part No.
	[mm]	[mm]	[mm]		[N]	[kg]	
	32	12	79	G 1/8	840	1.75	0821401130
	40	16	81		1100	1.75	0821401131
	50, 63	20	100		2700	3	0821401132
	80, 100	25	140		5800	8.8	0821401133

Holding force at 0 bar

Mounting elements LU3, LU4, LU5 are required for assembly and must be ordered separately as accessories.

Piston rod cylinders ▶ Standard cylinders

ISO 15552, Series PRA Accessories

Dimensions

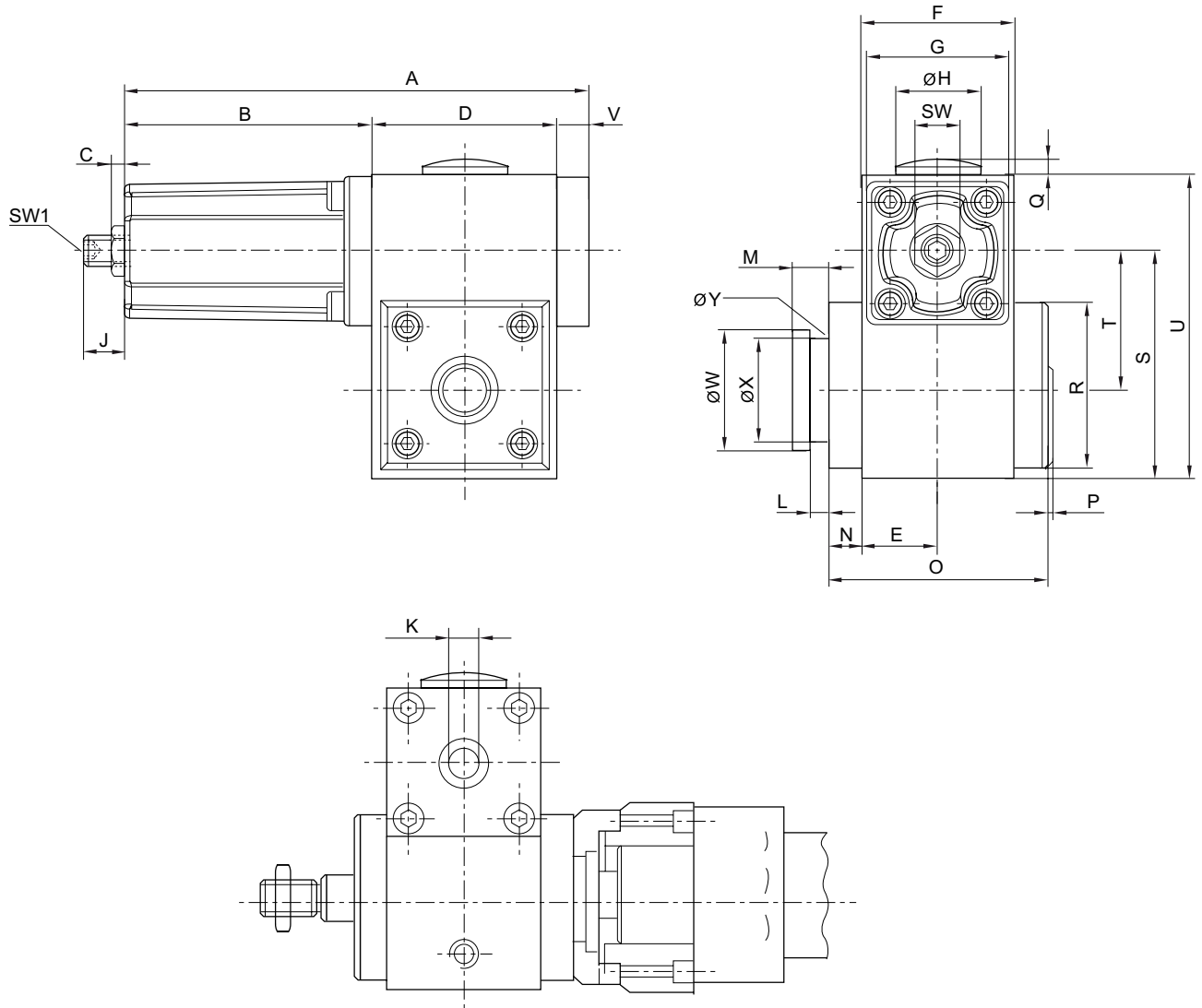

00119254_a

Piston Ø	A	B	C	D	E	F	G	ØH	J	K	L	M	N
32	135	69	10	56	23	46	45	30	19	G 1/8	4.1	8	9
40	135	69	10	56	23	46	45	30	18	G 1/8	5.1	10	9
50, 63	169	90	10	69	30	60	55	30	17	G 1/8	5.1	10	9
80, 100	208	98	16.7	100	40	80	65	37.5	15	G 1/8	8.1	16	13

Piston Ø	O	P	Q	R	S	SW	SW1	T	U	V	ØW	ØX	ØY
32	65	3	2.5	50	69	15	5	41.9	92	10	29.9	24	3
40	65	3	2.5	50	69	15	5	40.5	92	10	39.9	30	3
50, 63	84	3	2.5	60	80	15	5	48	111	10	39.9	30	3
80, 100	118	3	2	90	119	24	8	72	155	10	54.9	40	5

Part numbers marked in bold are available from the central warehouse in Germany, see the shopping basket for more detailed information

Pneumatics catalog, online PDF, as of 2017-05-02, ©AVENTICS S.à r.l., subject to change

ISO 15552, Series PRA Accessories

Locking unit, Series LU1

▶ Ø32 - 100 mm ▶ hold: spring force, release: compressed air



00119253

Function	Clamp with eccentric tappet
Release pressure	See table below
Ambient temperature min./max.	-20 °C / +80 °C
Medium temperature min./max.	-20 °C / +80 °C
Max. particle size	5 µm
Oil content of compressed air	0 mg/m ³ - 5 mg/m ³
Static holding force	See table below
Materials:	
Housing	Aluminum, anodized
Cover	Die-cast aluminum

Technical Remarks

- The pressure dew point must be at least 15 °C under ambient and medium temperature and may not exceed 3 °C.
- The oil content of compressed air must remain constant during the life cycle.
- Use only the approved oils from AVENTICS, see chapter „Technical information“.
- Warning: The Locking unit may not be used for the following applications:- for dynamic holding- in or as safety equipment
- Locking unit may only be unlocked when turned off.

	Piston Ø	suitable piston rod Ø	Piston rod extension	Compressed air connection	Release pressure	Static holding force	Weight	Part No.
	[mm]	[mm]	[mm]		[bar]	[N]	[kg]	
	32	12	79	G 1/8	4.5 / 8	740	1.52	R412003730
	40	16	81		4.5 / 8	1000	1.5	R412003731
	50, 63	20	100		4.5 / 8	2300	2.56	R412003732
	80, 100	25	140		4.5 / 8	4000	7.7	R412003733
	32	12	79		5.5 / 8	840	1.52	0821401134
	40	16	81		5.5 / 8	1100	1.5	0821401135
	50, 63	20	100		5.5 / 8	2700	2.56	0821401136
	80, 100	25	140		5.5 / 8	5800	7.7	0821401137

Holding force at 0 bar

Mounting elements LU3, LU4, LU5 are required for assembly and must be ordered separately as accessories.

Piston rod cylinders ▶ Standard cylinders

ISO 1552, Series PRA Accessories

Dimensions

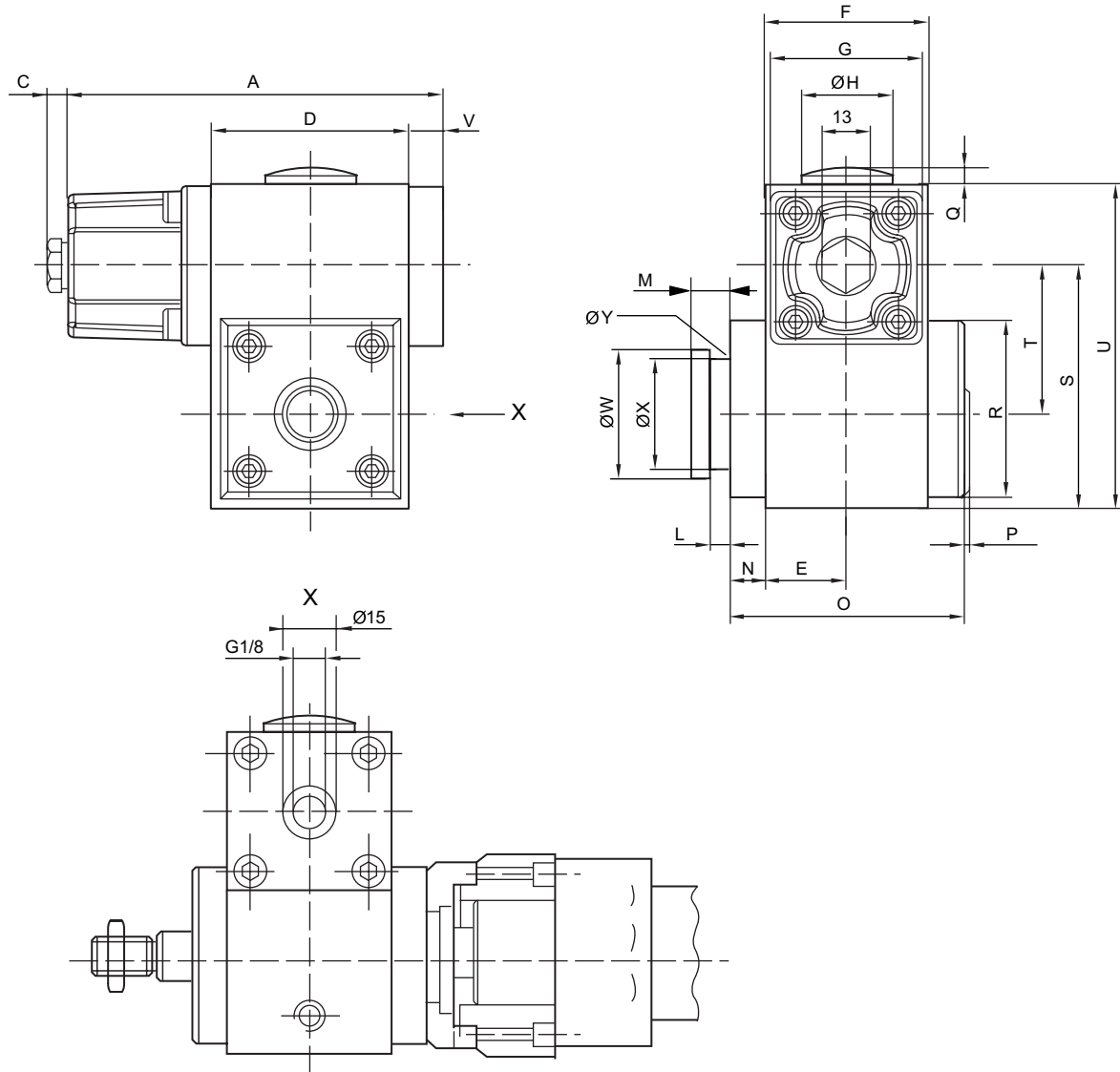

00119254

Piston Ø	A	C	D	E	F	G	Ø H	L	M	N	O	P	Q
32	106	6	56	23	46	45	30	4.1	8	9	65	3	2.5
40	106	6	56	23	46	45	30	5.1	10	9	65	3	2.5
50, 63	139.5	6	69	30	60	55	30	5.1	10	9	83.5	3	2.5
80, 100	176.5	6	100	40	80	65	37.5	8.1	16	13	118	3	2

Piston Ø	R	S	T	U	V	Ø W	Ø X	Ø Y					
32	50	68.5	41.9	91.5	10	29.9	24	3					
40	50	68.5	40.5	91.5	10	39.9	30	3					
50, 63	60	79.5	48	110	10	39.9	30	3					
80, 100	90	119	72	155	10	54.9	40	5					

Part numbers marked in bold are available from the central warehouse in Germany, see the shopping basket for more detailed information

Pneumatics catalog, online PDF, as of 2017-05-02, ©AVENTICS S.à r.l., subject to change

ISO 15552, Series PRA
Accessories
Locking unit, Series LU6

▶ Ø32 - 125 mm ▶ Holding and braking: non-adjustable spring, Release: compressed air



00134922

Version	Clamping jaw lock
Function	Static holding Dynamic braking
Release pressure	4 bar / 10 bar
Ambient temperature min./max.	-25 °C / +80 °C
Medium temperature min./max.	-25 °C / +80 °C
Medium	Compressed air
Max. particle size	5 μm
Oil content of compressed air	0 mg/m ³
Materials:	
Housing	Aluminum, anodized
Seal	Nitrile butadiene rubber
Scraper	Nitrile butadiene rubber

Technical Remarks

- The pressure dew point must be at least 15 °C under ambient and medium temperature and may not exceed 3 °C.
- The maximum ambient and medium temperature is +70 °C for the dynamic braking function.
- Note: Before pressurizing the locking unit, make sure that there is a balance of forces at the piston on the drive cylinder. Please see the operating instructions for further safety-relevant information. The locking unit can be used in controls with a max. performance level e in accordance with DIN EN ISO 13849-1 ("basic and well-tried safety principles"). For applications in category 2 to 4 controls, additional control measures according to DIN EN ISO 13849-1 are required.
- The locking unit can be used as an individual component or pre-mounted on a cylinder..
- Scope of delivery: LU6, each with 4 flange nuts, washers, and tie rods

Piston rod cylinders ▶ Standard cylinders
**ISO 15552, Series PRA
Accessories**

Piston Ø		[mm]	32	40	50	63	80
Max. holding/ braking force	F_{LU6}	[N]	760	1200	1900	3000	5000
Max. moving mass, external	m_{max}	[kg]	77	122	194	306	510
Max. piston speed	v_{max}	[m/s]	1	1	1	1	1
Max. total braking energy	E_{total}	[10 ⁶ J]	3.2	6	10	18	36
Max. braking energy per hour	P_{LU6}	[J/h]	720	1350	2250	4050	8100
Max. braking en- ergy per braking cycle	E_{LU6}	[J]	4.8	9	15	27	54
Braking energy per braking cycle related to B10d	E_{B10d}	[J]	1.6	3	5	9	18
Brake response time (4 bar)	t_{brake}	[s]	0.08	0.08	0.08	0.08	0.08
Brake response time (6.3 bar)	t_{brake}	[s]	0.1	0.1	0.1	0.1	0.1
Brake response time (10 bar)	t_{brake}	[s]	0.12	0.12	0.12	0.12	0.12

Piston Ø		[mm]	100	125			
Max. holding/ braking force	F_{LU6}	[N]	8000	12000			
Max. moving mass, external	m_{max}	[kg]	815	1223			
Max. piston speed	v_{max}	[m/s]	1	1			
Max. total braking energy	E_{total}	[10 ⁶ J]	58	93			
Max. braking energy per hour	P_{LU6}	[J/h]	13200	21000			
Max. braking en- ergy per braking cycle	E_{LU6}	[J]	88	140			
Braking energy per braking cycle related to B10d	E_{B10d}	[J]	29	47			
Brake response time (4 bar)	t_{brake}	[s]	0.09	0.09			
Brake response time (6.3 bar)	t_{brake}	[s]	0.11	0.11			
Brake response time (10 bar)	t_{brake}	[s]	0.13	0.13			

	Piston Ø	suitable pis- ton rod Ø	Piston rod extension	Compressed air connec- tion	Required flow rate	Weight	Max. torsional moment of piston rod	Part No.
	[mm]	[mm]	[mm]		Qn	[kg]	[Nm]	
					[l/min]			
	32	12	125	G 1/8	50	0.8	0.5	5230996402
	40	16	125	G 1/8	70	1	1	5231996402
	50	20	145	G 1/8	140	1.8	2	5232996402
	63	20	165	G 1/8	240	2.8	2.5	5233996402
	80	25	185	G 1/8	450	5.5	5	5234996402
	100	25	220	G 1/8	700	9.5	9	5235996402
	125	32	220	G 1/4	1200	13.8	15	5236996402

Part numbers marked in bold are available from the central warehouse in Germany, see the shopping basket for more detailed information

Pneumatics catalog, online PDF, as of 2017-05-02, ©AVENTICS S.à r.l., subject to change

ISO 15552, Series PRA
Accessories

Part No.	B10d value static	B10d value dynamic	Buckling protection of the piston rod 1)	
			Max. cylinder stroke for Euler case 1	Max. cylinder stroke for Euler case 2
			[mm]	[mm]
5230996402	5.000.000	2.000.000	750	400
5231996402			1100	550
5232996402			1350	700
5233996402			950	500
5234996402			1350	700
5235996402			950	500
5236996402			1500	800

1) Only applies in dynamic cases, and only retracting

Formulas and sample calculations

Brake force pre-selection, locking unit LU6	Example: 30 kg load (brakes)
$F_{load} = m * g * 2$ (safety factor) $F_{LU6} \geq F_{load}$	$588,6 \text{ N} = F_{load}$ $760 \text{ N for } \varnothing 32 = F_{LU6}$
Pre-selection, PRA /TRB cylinder diameter	Example: 30 kg load, 500 mm stroke, 6 bar, vertical movement, cycle time 0.65 s
a) Cylinder diameter test	→ Calculation Tool: Test both movement directions $\varnothing 32$: Too much energy $\varnothing 40$: correct energy
b) Piston speed test	→ Calculation Tool
$v_{load} \leq v_{max}$	$0,77 \text{ m/s} = v_{load}$ $1,00 \text{ m/s} = v_{max}$
c) Brake energy test	
$E_{load} = 1/2 m * v^2$ $E_{LU6} \geq E_{load}$	$8,9 \text{ J} = E_{load}$ $9,0 \text{ J} = E_{LU6}$
Test: LU6 performance	Example: 30 kg load, 120 brakes per hour
$P_{load} = E_{load} * n_{brake}$ $P_{LU6} \geq P_{load}$	$1067,2 \text{ J/h} = P_{load}$ $1350 \text{ J/h} = P_{LU6}$
Calculation of the expected service life	Example: 30 kg load, LU6 $\varnothing 40$
$E_{total} / E_{load} = B10d$ $B10d \leq 2 * 10^6$	$674.650 = B10d$
Calculation of the braking distance	
$S_{brake} = S_{dead\ time} + S_{LU6}$ $S_{dead\ time} = (t_{brake} + t_{valve}) * v_{load}$ $S_{LU6} = E_{load} / F_{LU6}$	t_{valve} = depending on the valve used

Piston rod cylinders ▶ Standard cylinders

**ISO 1552, Series PRA
Accessories**

**Circuit example for non-safety relevant functions:
mounting orientation horizontal**

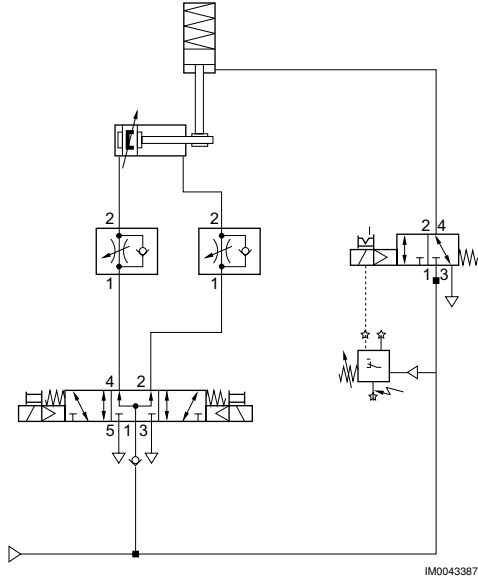

Vertical mounting orientation

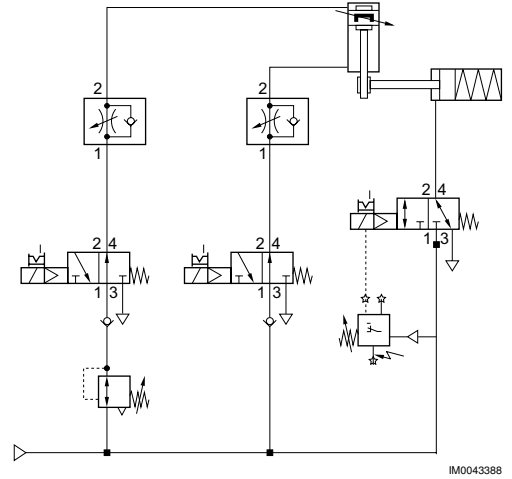

**Circuit example for safety-related stop functions:
mounting orientation horizontal**

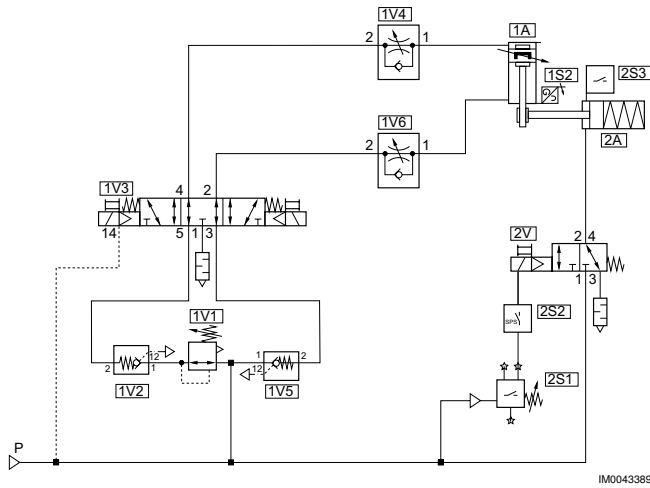

Channel 1: Safe stopping and closing
Channel 2: Safe brake control

Vertical mounting orientation

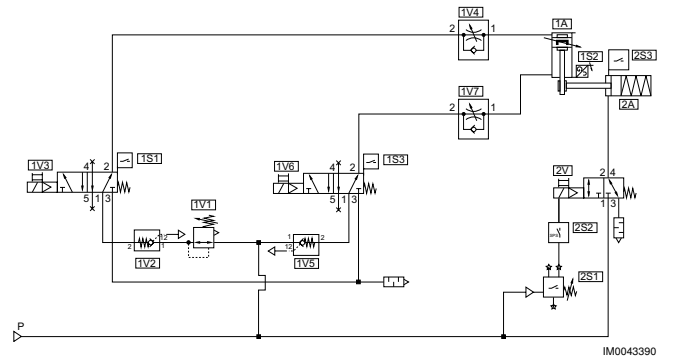

Channel 1: Safe stopping and closing
Channel 2: Safe brake control

ISO 1552, Series PRA

Accessories

Dimensions

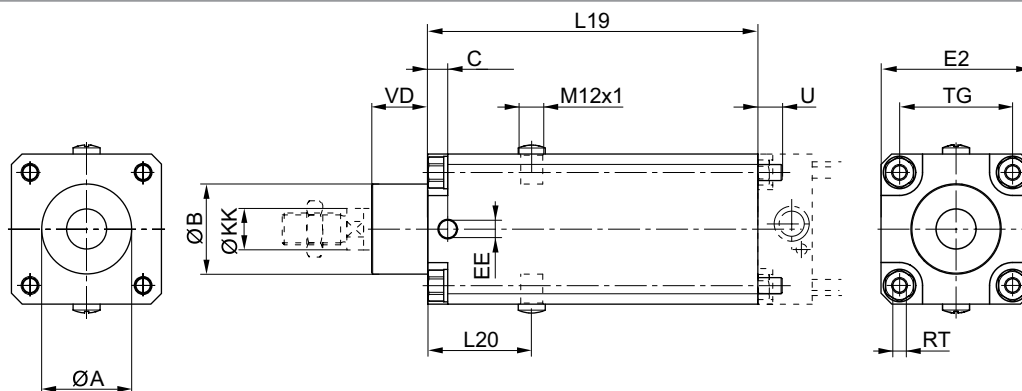

00134223

Piston Ø	ØA	ØB d11	C	EE	E2	L19	L20	ØKK e8-h9	TG	RT	U	VD
32	30,5	30	9	G1/8	48	125	44	12	32,5	M6	10	19
40	35,5	35	9	G1/8	53	125	44	16	38	M6	10	21
50	40,5	40	9	G1/8	63	145	49	20	46,5	M8	11	28
63	45,5	45	10	G1/8	75	165	52	20	56,5	M8	11	28
80	45,5	45	11	G1/8	98	185	61,5	25	72	M10	16	34
100	55,5	55	13	G1/8	118	220	68	25	89	M10	16	37
125	60,5	60	13	G1/4	142	220	75	32	110	M12	16	45

Foot mounting, Series LU4

▶ for cylinders with locking units



23489

Ambient temperature min./max.

-20°C / +80°C

Medium temperature min./max.

-20°C / +80°C

Max. particle size

5 µm

Oil content of compressed air

0 mg/m³ - 5 mg/m³

Materials:

Housing

Nodular graphite iron, galvanized

Technical Remarks

- The pressure dew point must be at least 15 °C under ambient and medium temperature and may not exceed 3 °C.
- The oil content of compressed air must remain constant during the life cycle.
- Use only the approved oils from AVENTICS, see chapter „Technical information“.

Piston rod cylinders ▶ Standard cylinders

ISO 15552, Series PRA Accessories

	For piston Ø	Part No.
	[mm]	
	32	1827001520
	40	1827001521
	50	1827001522
	63	1827001526
	80	1827001524
	100	1827002152

Dimensions

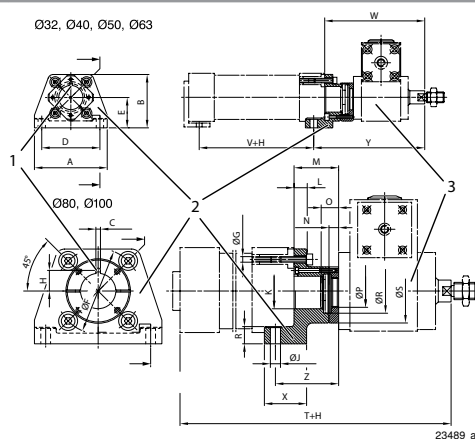

H = stroke

The locking unit can be rotated by 4x90°.

A	B	C ±0,1	D ±0,1	E	Ø F	Ø G H13	I	J H8	K H10	L	M	N	O	Ø P
79	57	3.6	65	32	46	6.6	13.2	6.6	30	7	27	3.9	-	24.2
90	64	3.6	75	36	54	6.6	18.2	6.6	35	9.5	33	4.9	13	30.2
110	80	3.6	90	45	66	8.4	18.2	9	40	11	38	4.9	-	30.2
120	90	3.6	100	50	80	8.4	18.2	9	45	11	38	4.9	-	30.2
153	113	6	128	63	102	10.5	24.5	11	45	15	52	7.9	18	40.2
176	133	6	148	71	126	10.5	24.6	11	55	15	57	7.9	-	40.2

A	R	Ø R	Ø S	T	V	W	X	Y	Z					
79	9	30	46.5	199	68	105	32	118	40					
90	11	40	55.5	216	79	111	32	124	46					
110	15	40	66	243	74	137	41	153	54					
120	15	40	71	258	89	137	41	153	54					
153	19.5	55	75	314	84	186	50	208	74					
176	19.5	55	80	329	94	191	50	213	79					

Part numbers marked in bold are available from the central warehouse in Germany, see the shopping basket for more detailed information

Pneumatics catalog, online PDF, as of 2017-05-02, ©AVENTICS S.à r.l., subject to change

Flange mounting, Series LU5 ▶ for cylinders with locking units



23490

Ambient temperature min./max.	-20 °C / +80 °C
Medium temperature min./max.	-20 °C / +80 °C
Max. particle size	5 μm
Oil content of compressed air	0 mg/m ³ - 5 mg/m ³

Materials:	
Housing	Nodular graphite iron, galvanized

Technical Remarks

- The pressure dew point must be at least 15 °C under ambient and medium temperature and may not exceed 3 °C.
- The oil content of compressed air must remain constant during the life cycle.
- Use only the approved oils from AVENTICS, see chapter „Technical information“.

	For piston Ø	Part No.
	[mm]	
	32	1827001512
	40	1827001513
	50	1827001514
	63	1827001503
	80	1827001516
	100	1827001517

Dimensions

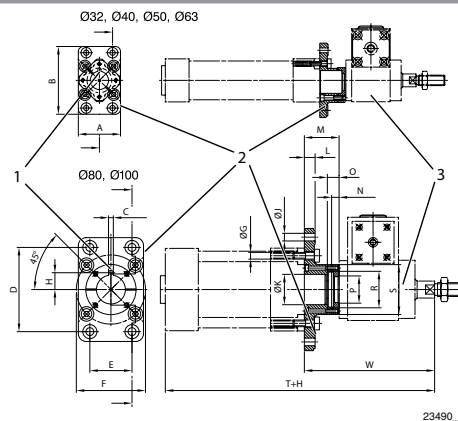

A	B	C ±0,1	D ±0,1	E ±0,1	Ø F ±0,2	Ø G H13	H	Ø J H13	Ø K H10	L	M	N ±0,1	O 1)	Ø P +0,2
50	79	3.6	64	32	46	6.6	13.2	7	30	8	27	3.9	8	24.2

Part numbers marked in bold are available from the central warehouse in Germany, see the shopping basket for more detailed information

Pneumatics catalog, online PDF, as of 2017-05-02, ©AVENTICS S.à r.l., subject to change

Piston rod cylinders ▶ Standard cylinders

ISO 15552, Series PRA Accessories

A	B	C ±0,1	D ±0,1	E ±0,1	Ø F ±0,2	Ø G H13	H	Ø J H13	Ø K H10	L	M	N ±0,1	O 1)	Ø P +0,2
56	91	3.6	72	36	54	6.6	18.2	9	35	10	33.3	4.9	10	30.2
70	111	3.6	90	45	66	8.4	18.2	9	40	12	38.3	4.9	10	30.2
80	120	3.6	100	50	80	8.4	18.2	9	45	12	38.3	4.9	10	30.2
100	153	6	126	63	102	10.5	24.5	12	45	16	52	7.9	16	40.2
120	178	6	150	75	126	10.5	24.6	14	55	16	57	7.9	16	40.2

A	Ø R +0,5	Ø S	W											
50	33	50	105											
56	40	55.5	111											
70	40	66	137											
80	40	71	137											
100	55	75	186											
120	55	80	191											

1) Min.

Mounting flange, Series LU3

▶ for cylinders with locking units



23488

Ambient temperature min./max.

-20 °C / +80 °C

Medium temperature min./max.

-20 °C / +80 °C

Max. particle size

5 µm

Oil content of compressed air

0 mg/m³ - 5 mg/m³

Materials:

Housing

Nodular graphite iron, galvanized

Technical Remarks

- The pressure dew point must be at least 15 °C under ambient and medium temperature and may not exceed 3 °C.
- The oil content of compressed air must remain constant during the life cycle.
- Use only the approved oils from AVENTICS, see chapter „Technical information“.

For piston Ø	Weight	Part No.
[mm]	[kg]	
32	0.235	1827001504
40	0.36	1827001505
50	0.635	1827001506
63	0.84	1827001508
80	1.62	1827001433
100	2.27	1827001434

Part numbers marked in bold are available from the central warehouse in Germany, see the shopping basket for more detailed information

Pneumatics catalog, online PDF, as of 2017-05-02, ©AVENTICS S.à r.l., subject to change

ISO 15552, Series PRA Accessories

Dimensions

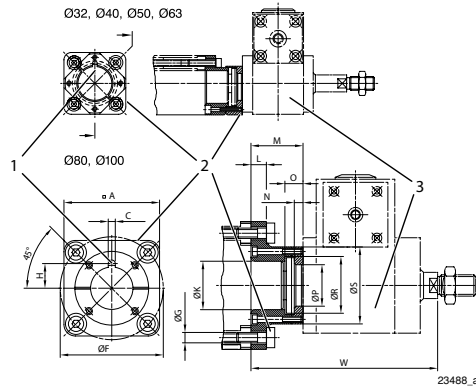

Screws included in scope of delivery
The locking unit can be rotated by 4x90°.

A	C +0,1	Ø F ±0,2	G H13	H	Ø K H10	L	M	N -0,1	O 1)	Ø P +0,2	Ø R +0,5	Ø S	W
50	3.6	46	6.6	13.2	30	7	27.2	3.9	8	24.2	33	46.5	105
57	3.6	54	6.6	18.2	35	9.5	33.3	4.9	10	30.2	40	55.5	111
68	3.6	66	8.4	18.2	40	11	38.3	4.9	10	30.2	40	66	137
75	3.6	80	8.4	18.2	45	11	38.3	4.9	10	30.2	40	71	137
95	6	102	10.5	24.5	45	15	52	7.9	16	40.2	55	75	186
115	6	126	10.5	24.6	55	15	57	7.9	16	40.2	55	80	191

1) Min.

Piston rod cylinders ▶ Standard cylinders

ISO 15552, Series PRA
Accessories

Sensor, Series ST6

▶ 6 mm T-slot ▶ with cable ▶ open cable ends, 2-pin, open cable ends, 3-pin



24712

Certificates	CE declaration of conformity cULus RoHS
Ambient temperature min./max.	-30°C / +80°C
Protection class	IP65, IP67, IP69K
Switching point precision [mm]	±0,1
Switching logic	NO (make contact)
Switching capacity	Reed, 2-pin: max. 10 W Reed, 3-pin: max. 6 W
LED status display	Yellow
Vibration resistance	10 - 55 Hz, 1 mm
Shock resistance	30 g / 11 ms
Materials:	
Housing	Polyamide
Cable sheath	Polyurethane
Locking screw	Stainless steel

Technical Remarks

- No cULus certification for 230 V variant.

	Type of contact	Cable length	DC operating voltage min./max.	Operational voltage AC min./max.	Voltage drop U at I _{max}	DC switching current, max.	AC switching current, max.	Part No.
		[m]	[V DC]	[V AC]		[A]	[A]	
	Reed	3	10 / 230	10 / 230	I*Rs	0.13	0.13	R412022866
	Reed	3 5 10	10 / 30	10 / 30	I*Rs	0.3	0.5	R412022869 R412022870 R412022871
	electronic PNP	3 5 10	10 / 30	-	≤ 2,5 V	0.13	-	R412022853 R412022855 R412022857
	electronic NPN	3 5	10 / 30	-	≤ 2,5 V	0.13	-	R412022849 R412022850

Part No.	Max. switching frequency kHz	Operating current, not switched	Operating current, switched	Fig.	Note
R412022866	< 0,4	-	-	Fig. 1	1); 3)
R412022869 R412022870 R412022871	< 0,4	-	-	Fig. 2	2); 3)
R412022853 R412022855 R412022857	< 1,0	< 8 mA	< 30 mA	Fig. 2	2); 4)
R412022849 R412022850	< 1,0	< 8 mA	< 30 mA	Fig. 2	2); 4)

- 1) interfaces: open cable ends; 2-pin
- 2) interfaces: open cable ends; 3-pin
- 3) Protected against polarity reversal
- 4) short circuit resistant / Protected against polarity reversal

ISO 15552, Series PRA Accessories

Fig. 1

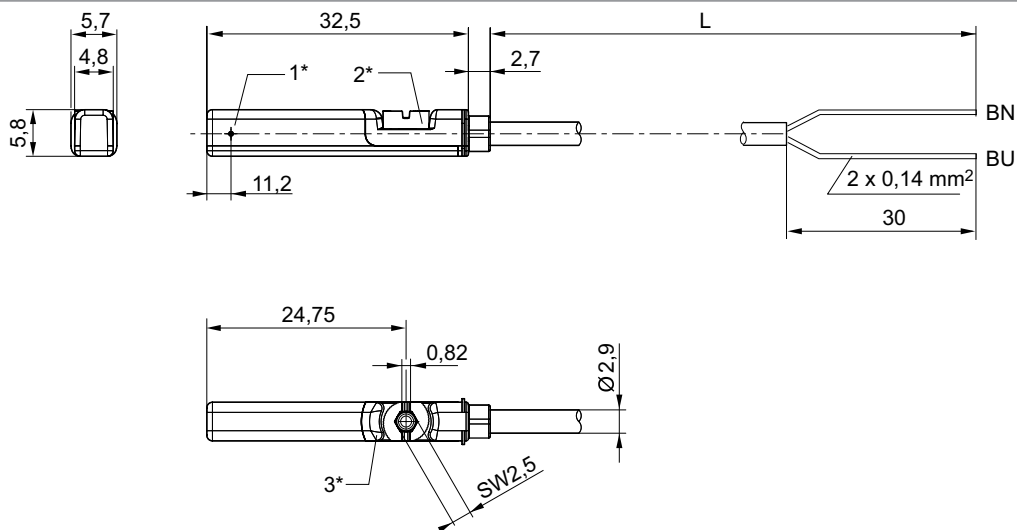

24619

1* = switching point 2* = locking screw 3* = LED window, transparent
L = cable length
BN=brown, BU=blue

Fig. 2

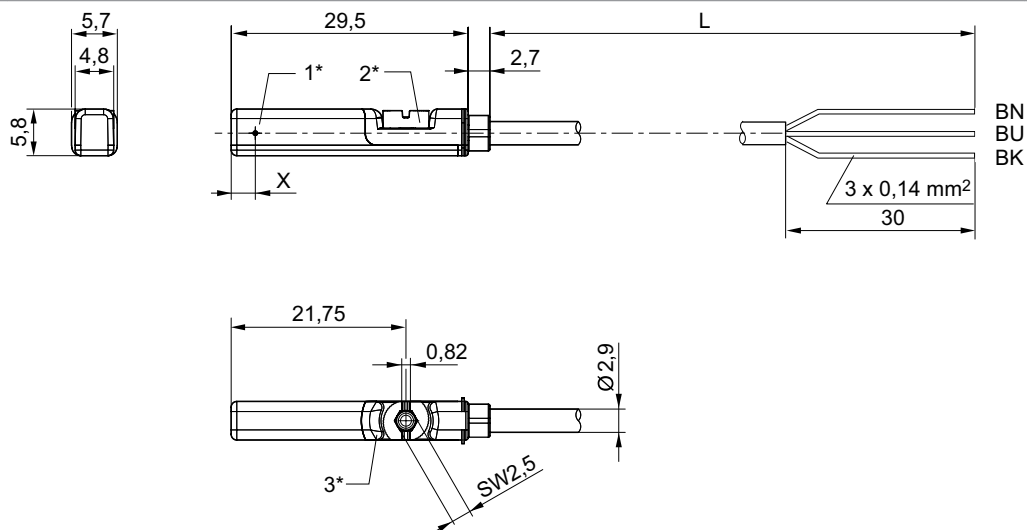

24620

1* = switching point 2* = locking screw 3* = LED window, transparent
L = cable length
BN = brown, BK = black, BU = blue
X = electronic: 11,6 mm, Reed: 8,3 mm

Piston rod cylinders ▶ Standard cylinders

ISO 15552, Series PRA
Accessories

Sensor, Series ST6

▶ 6 mm T-slot ▶ with cable ▶ open cable ends, 3-pin ▶ ATEX certified



24712

Certificates

CE declaration of conformity
cULus
RoHS

ATEX

II 3G Ex nA op is IIC T4 Gc X
II 3D Ex tc IIIC T135°C Dc X

Ambient temperature min./max.

-20°C / +50°C

Protection class

IP67

Switching point precision [mm]

±0,1

Quiescent current (without load)

< 10 mA

DC operating voltage min./max.

10 V DC - 30 V DC

Switching logic

NO (make contact)

LED status display

Yellow

Vibration resistance

10 - 55 Hz, 1 mm

Shock resistance

30 g / 11 ms

Materials:

Housing

Polyamide

Cable sheath

Polyurethane

Locking screw

Stainless steel

	Type of contact	Cable length	Voltage drop U at I _{max}	DC switching current, max.	Max. switching frequency kHz	Part No.
		[m]		[A]		
	electronic PNP	3	≤ 2,5 V	0.1	< 1,0	R412022854
		5				R412022856

interfaces: open cable ends; 3-pin
short circuit resistant / Protected against polarity reversal

ISO 15552, Series PRA

Accessories

Dimensions

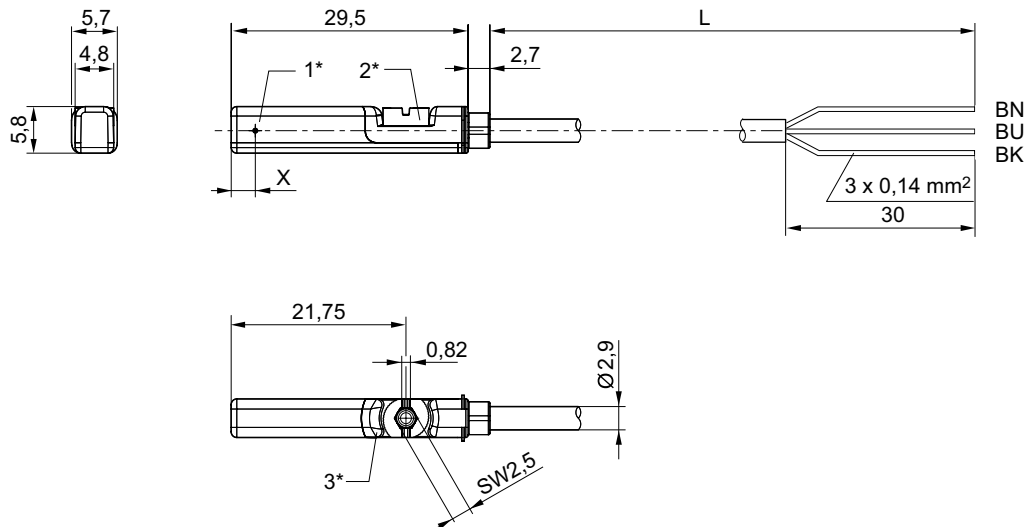

24620

1* = switching point 2* = locking screw 3* = LED window, transparent
 L = cable length
 BN = brown, BK = black, BU = blue
 X = electronic: 11.6 mm

Sensor, Series ST6

▶ 6 mm T-slot ▶ with cable ▶ Plug, M8, 3-pin, with knurled screw



24713

Certificates

Ambient temperature min./max.
 Protection class
 Switching point precision [mm]
 DC operating voltage min./max.
 Switching logic
 Switching capacity
 LED status display
 Vibration resistance
 Shock resistance

Materials:

Housing
 Locking screw

CE declaration of conformity

cULus
 RoHS
 -30 °C / +80 °C
 IP65, IP67
 ±0,1
 10 V DC - 30 V DC
 NO (make contact)
 Reed, 3-pin: max. 6 W
 Yellow
 10 - 55 Hz, 1 mm
 30 g / 11 ms

Polyamide
 Stainless steel



	Type of contact	Cable sheath	Cable length	Operational voltage AC min./max.	Voltage drop U at I _{max}	DC switching current, max.	AC switching current, max.	Part No.
			[m]	[V AC]		[A]	[A]	
	Reed	Polyurethane	0.3	10 / 30	I*Rs	0.3	0.5	R412022873
		Polyvinyl chloride	0.3					R412022875
		Polyurethane	0.5					R412022874

Part numbers marked in bold are available from the central warehouse in Germany, see the shopping basket for more detailed information

Pneumatics catalog, online PDF, as of 2017-05-02, ©AVENTICS S.à.r.l., subject to change

Piston rod cylinders ▶ Standard cylinders

ISO 1552, Series PRA Accessories

	Type of contact	Cable sheath	Cable length	Operational voltage AC min./max.	Voltage drop U at I _{max}	DC switching current, max.	AC switching current, max.	Part No.
			[m]	[V AC]		[A]	[A]	
	electronic PNP	Polyurethane	0.3	-	≤ 2,5 V	0.13	-	R412022859
		Polyvinyl chloride	0.3					R412022862
		Polyurethane	0.5					R412022861
	electronic NPN	Polyurethane	0.3	-	≤ 2,5 V	0.13	-	R412022852

Part No.	Max. switching frequency kHz	Operating current, not switched	Operating current, switched	Note
R412022873 R412022875 R412022874	< 0,4	-	-	1)
R412022859 R412022862 R412022861	< 1,0	< 8 mA	< 30 mA	2)
R412022852	< 1,0	< 8 mA	< 30 mA	2)

1) Protected against polarity reversal
 2) short circuit resistant / Protected against polarity reversal
 interfaces: Plug; M8; 3-pin; with knurled screw

Dimensions

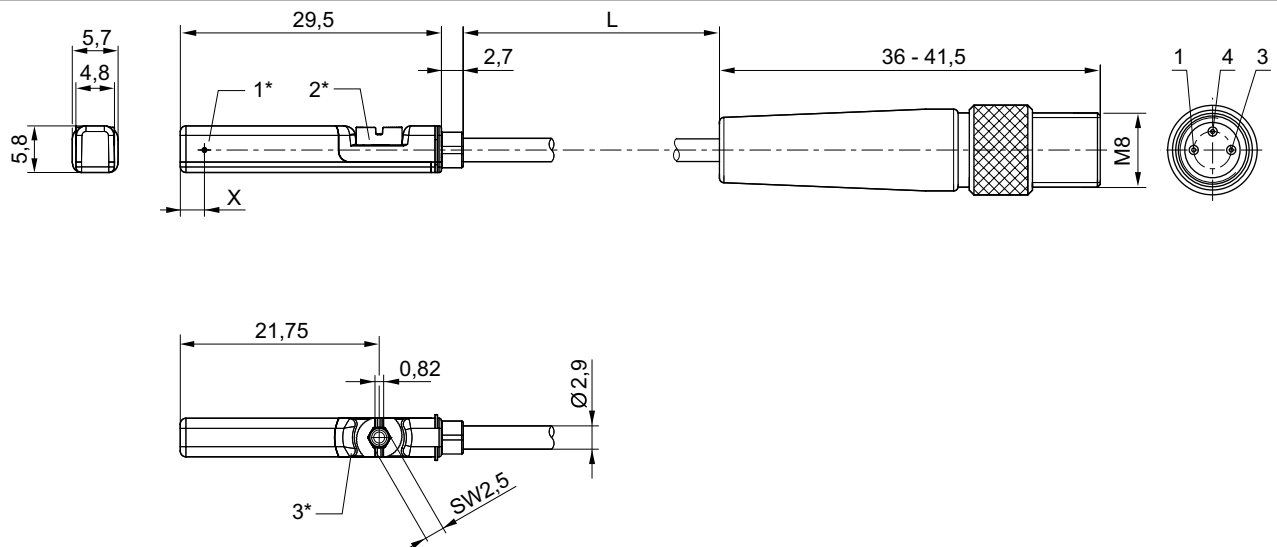

1* = switching point 2* = locking screw 3* = LED window, transparent
 L = cable length
 X = electronic: 11,6 mm, Reed: 8,3 mm
 Pin assignment: 1 = (+), 3 = (-), 4 = (OUT)

24622

ISO 15552, Series PRA

Accessories

Sensor, Series ST6

▶ 6 mm T-slot ▶ with cable ▶ Plug, M8, 3-pin, with knurled screw ▶ ATEX certified



24713

Certificates	CE declaration of conformity cULus RoHS II 3G Ex nA op is IIC T4 Gc X II 3D Ex tc IIIC T135°C Dc X
ATEX	
Ambient temperature min./max.	-20°C / +50°C
Protection class	IP67
Switching point precision [mm]	±0,1
Quiescent current (without load)	< 10 mA
DC operating voltage min./max.	10 V DC - 30 V DC
Switching logic	NO (make contact)
LED status display	Yellow
Vibration resistance	10 - 55 Hz, 1 mm
Shock resistance	30 g / 11 ms
Materials:	
Housing	Polyamide
Cable sheath	Polyurethane
Locking screw	Stainless steel

	Type of contact	Cable length	Voltage drop U at I _{max}	DC switching current, max.	Max. switching frequency kHz	Part No.
		[m]		[A]		
	electronic PNP	0.3	≤ 2,5 V	0.1	< 1,0	R412022860

interfaces: Plug; M8; 3-pin; with knurled screw
short circuit resistant / Protected against polarity reversal

Piston rod cylinders ▶ Standard cylinders

ISO 15552, Series PRA Accessories

Dimensions

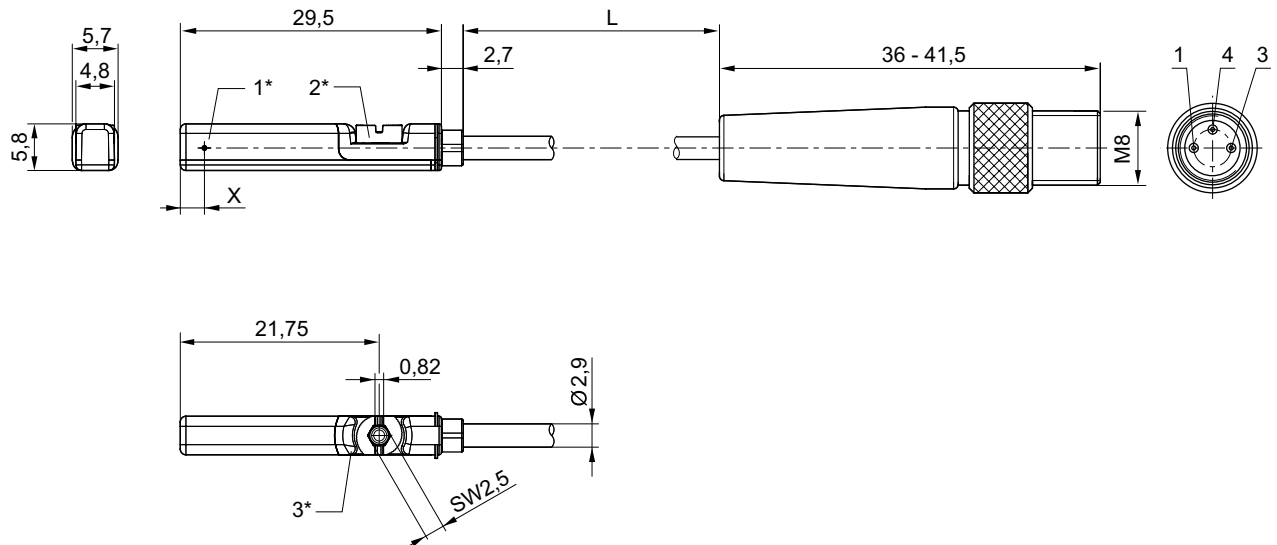

1* = switching point 2* = locking screw 3* = LED window, transparent
 L = cable length
 X = PNP: 11,6 mm
 Pin assignment: 1 = (+), 3 = (-), 4 = (OUT)

24622

Sensor, Series ST6

▶ 6 mm T-slot ▶ with cable ▶ Plug, M8, 3-pin



24742

Certificates

Ambient temperature min./max.
 Protection class
 Switching point precision [mm]
 DC operating voltage min./max.
 Switching logic
 Switching capacity

LED status display
 Vibration resistance
 Shock resistance

Materials:

Housing
 Cable sheath
 Locking screw

CE declaration of conformity

cULus
 RoHS
 -30°C / +80°C
 IP65, IP67
 ±0,1
 10 V DC - 30 V DC
 NO (make contact)
 Reed, 2-pin: max. 10 W
 Reed, 3-pin: max. 6 W
 Yellow
 10 - 55 Hz, 1 mm
 30 g / 11 ms



Polyamide
 Polyurethane
 Stainless steel

	Type of contact	Cable length	Operational voltage AC min./max.	Voltage drop U at I _{max}	DC switching current, max.	AC switching current, max.	Max. switching frequency kHz	Part No.
		[m]	[V AC]		[A]	[A]		
	Reed	0.3	10 / 30	I*Rs	0.13	0.13	< 0,4	R412022868

Part numbers marked in bold are available from the central warehouse in Germany, see the shopping basket for more detailed information

Pneumatics catalog, online PDF, as of 2017-05-02, ©AVENTICS S.à r.l., subject to change

ISO 15552, Series PRA Accessories

	Type of contact	Cable length	Operational voltage AC min./max.	Voltage drop U at I _{max}	DC switching current, max.	AC switching current, max.	Max. switching frequency kHz	Part No.
		[m]	[V AC]		[A]	[A]		
	Reed	0.3	10 / 30	I [*] Rs	0.3	0.5	< 0,4	R412022872
	electronic PNP	0.3	-	≤ 2,5 V	0.13	-	< 1,0	R412022858
	electronic NPN	0.3	-	≤ 2,5 V	0.13	-	< 1,0	R412022851

Part No.	Operating current, not switched	Operating current, switched	Note
R412022868	-	-	1)
R412022872	-	-	1)
R412022858	< 8 mA	< 30 mA	2)
R412022851	< 8 mA	< 30 mA	2)

1) Protected against polarity reversal

2) short circuit resistant / Protected against polarity reversal

interfaces: Plug; M8; 3-pin

Dimensions

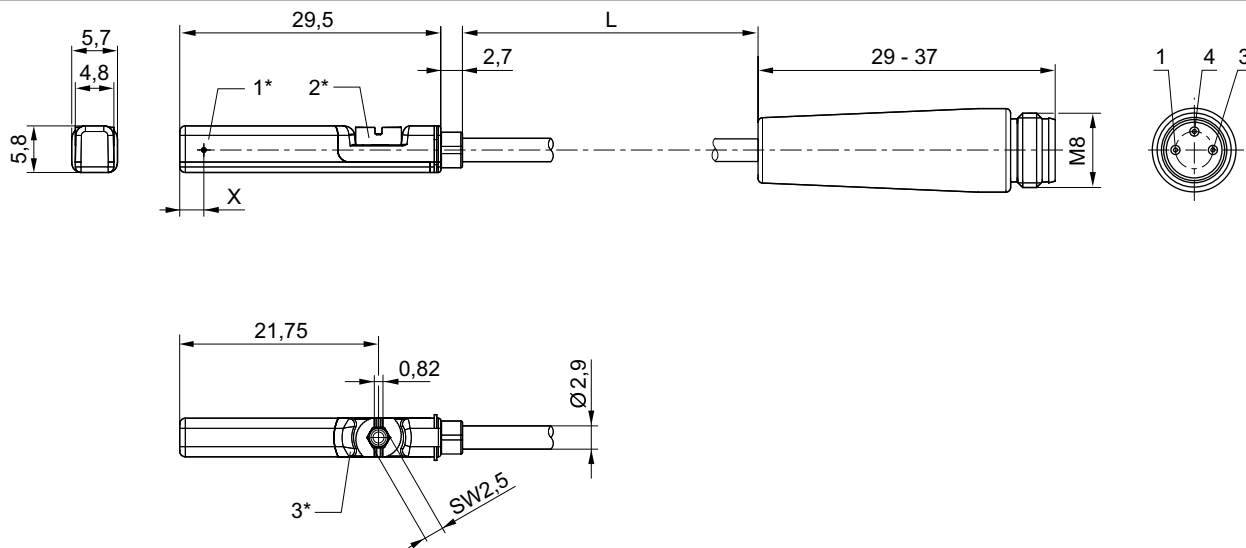

1* = switching point 2* = locking screw 3* = LED window, transparent

L = cable length

X = electronic: 11,6 mm, Reed: 8,3 mm

Pin assignment: 1 = (+), 3 = (-), 4 = (OUT)

24621

Piston rod cylinders ▶ Standard cylinders

ISO 15552, Series PRA
Accessories

Sensor, Series ST6

▶ 6 mm T-slot ▶ with cable ▶ Plug, M12, 3-pin, with knurled screw



24714

Certificates

Ambient temperature min./max.
Protection class
Switching point precision [mm]
DC operating voltage min./max.
Switching logic
Switching capacity
LED status display
Vibration resistance
Shock resistance



CE declaration of conformity
cULus
RoHS

-30°C / +80°C
IP65, IP67
±0,1
10 V DC - 30 V DC
NO (make contact)
Reed, 3-pin: max. 6 W
Yellow
10 - 55 Hz, 1 mm
30 g / 11 ms

Materials:

Housing
Cable sheath
Locking screw

Polyamide
Polyurethane
Stainless steel

	Type of contact	Cable length	Operational voltage AC min./max.	Voltage drop U at I _{max}	DC switching current, max.	AC switching current, max.	Max. switching frequency kHz	Part No.
		[m]	[V AC]		[A]	[A]		
	Reed	0.3	10 / 30	I*Rs	0.3	0.5	< 0,4	R412022876
	electronic PNP	0.1 0.3 3 5	-	≤ 2,5 V	0.13	-	< 1,0	R412022879 R412022863 R412022877 R412022878

Part No.	Operating current, not switched	Operating current, switched	Note
R412022876	-	-	1)
R412022879 R412022863 R412022877 R412022878	< 8 mA	< 30 mA	2)

1) Protected against polarity reversal
2) short circuit resistant / Protected against polarity reversal
interfaces: Plug; M12; 3-pin; with knurled screw

ISO 1552, Series PRA

Accessories

Dimensions

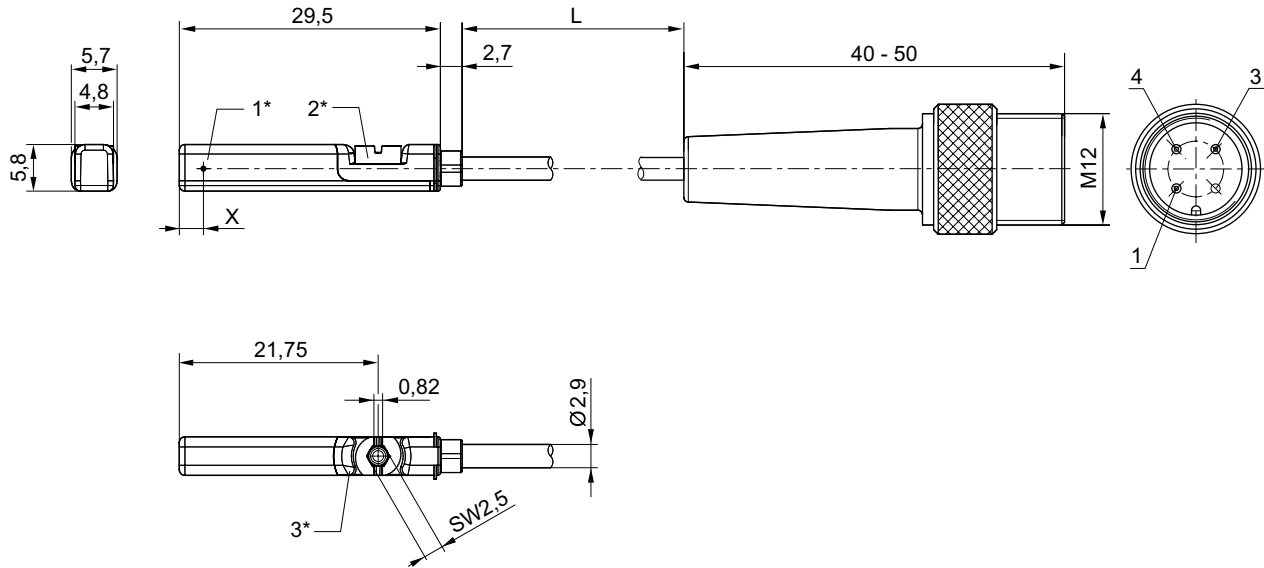

24623

1* = switching point 2* = locking screw 3* = LED window, transparent
 L = cable length
 X = PNP: 11,6 mm, reed: 8,3 mm
 Pin assignment: 1 = (+), 3 = (-), 4 = (OUT)

Sensor, Series ST6

▶ 6 mm T-slot ▶ with cable ▶ Plug, M12, 3-pin, with knurled screw ▶ ATEX certified



24714

Certificates

ATEX

Ambient temperature min./max.
 Protection class
 Switching point precision [mm]
 Quiescent current (without load)
 DC operating voltage min./max.
 Switching logic
 LED status display
 Vibration resistance
 Shock resistance

Materials:

Housing
 Cable sheath
 Locking screw

CE declaration of conformity
 cULus
 RoHS

II 3G Ex nA op is IIC T4 Gc X
 II 3D Ex tc IIIC T135°C Dc X

-20°C / +50°C

IP67

±0,1

< 10 mA

10 V DC - 30 V DC

NO (make contact)

Yellow

10 - 55 Hz, 1 mm

30 g / 11 ms

Polyamide

Polyurethane

Stainless steel

Piston rod cylinders ▶ Standard cylinders

ISO 15552, Series PRA
Accessories

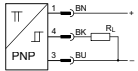
	Type of contact	Cable length	Voltage drop U at I _{max}	DC switching current, max.	Max. switching frequency kHz	Part No.
		[m]		[A]		
	electronic PNP	0.3	≤ 2,5 V	0.1	< 1,0	R412022864

interfaces: Plug; M12; 3-pin; with knurled screw
short circuit resistant / Protected against polarity reversal

Dimensions

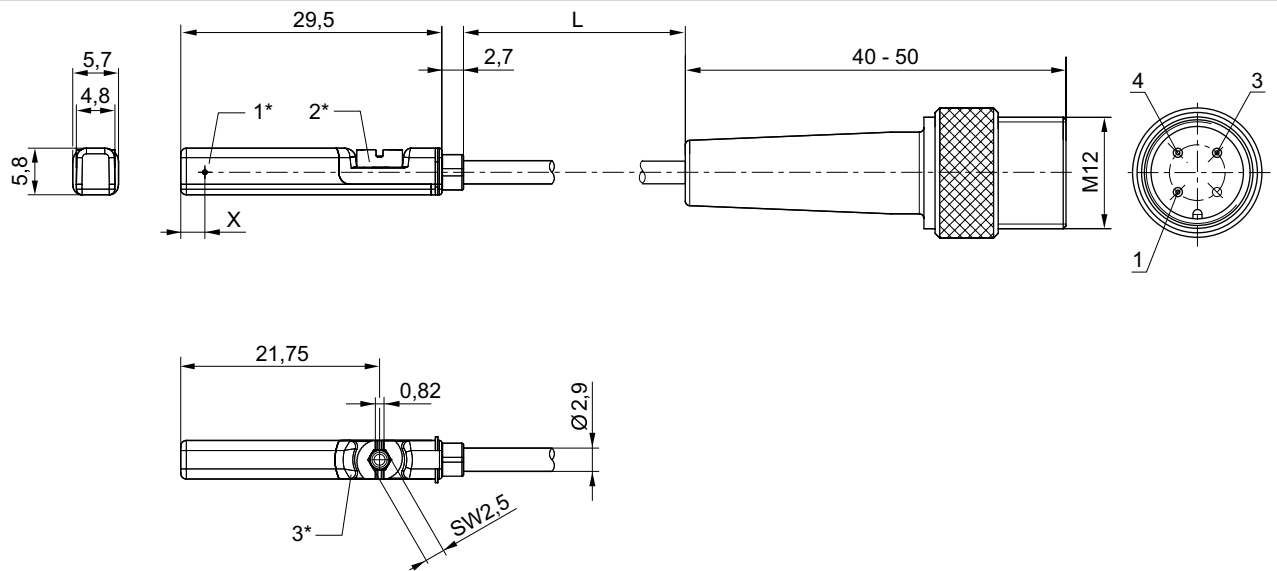

1* = switching point 2* = locking screw 3* = LED window, transparent
L = cable length
X = PNP: 11,6 mm
Pin assignment: 1 = (+), 3 = (-), 4 = (OUT)

24623

ISO 15552, Series PRA

Accessories

Sensor, Series ST6-HT

▶ 6 mm T-slot ▶ with cable ▶ open cable ends, 2-pin ▶ heat resistant



24712

Certificates

Ambient temperature min./max.
Protection class
Switching point precision [mm]
DC operating voltage min./max.
Switching logic
Switching capacity
Vibration resistance
Shock resistance

CE declaration of conformity
RoHS

-20°C / +120°C
IP65, IP67
±0,1
10 V DC - 30 V DC
NO (make contact)
Reed, 2-pin: max. 10 W
10 - 55 Hz, 1 mm
30 g / 11 ms

Materials:

Housing
Cable sheath
Locking screw

Polyamide
Polyurethane
Stainless steel

	Type of contact	Cable length	Operational voltage AC min./max.	Voltage drop U at I _{max}	DC switching current, max.	AC switching current, max.	Max. switching frequency kHz	Part No.
		[m]	[V AC]		[A]	[A]		
	Reed	3 10	0 / 30	I*Rs	0.13	0.13	< 0,4	R412022865 R412022867
interfaces: open cable ends; 2-pin Protected against polarity reversal								

Dimensions

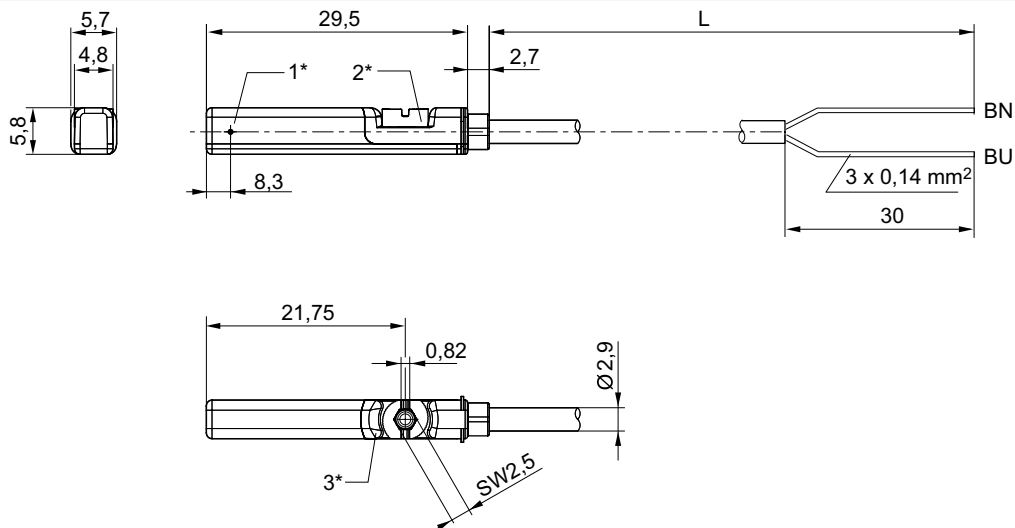

24619_a

1* = switching point 2* = locking screw 3* = LED window, transparent
L = cable length
BN=brown, BU=blue

Piston rod cylinders ▶ Standard cylinders

ISO 15552, Series PRA
Accessories

Sensors, Series SM6

▶ 6 mm groove ▶ with cable ▶ without wire end ferrule, tin-plated, 4-pin ▶ with distance measuring sensor, measurement range 32 - 256 mm

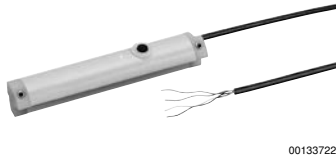

Certificates	cULus
Ambient temperature min./max.	-20°C / +70°C
Protection class	IP67
Output signal	0 - 10 V DC, 4 - 20 mA
Quiescent current (without load)	< 25 mA
Current signal	4 - 20 mA
Maximum load (analog current output)	500 Ω
DC operating voltage min./max.	15 V DC - 30 V DC
Residual ripple	≤ 10 %
sampling interval	1 ms
Resolution max. measuring range	0,05 mm
Repetitive precision max. measuring range	0.1 mm
Linearity deviation	0,3 mm
Sampling speed	3 m/s
Display	LED
LED status display	Yellow
Vibration resistance	10 - 55 Hz, 1 mm
Shock resistance	30 g / 11 ms

Materials:	
Housing	Polyamide, fiber-glass reinforced
Cable sheath	Polyurethane

	Type of contact	Cable length	Measurement range Max.	Overall length Sensor A	Part No.
		[m]	[mm]	[mm]	
	Analog	2	32	45	R412010141
			64	77	R412010143
			96	109	R412010262
			128	141	R412010264
			160	173	R412010411
			192	205	R412010413
			224	237	R412010415
			256	269	R412010417

interfaces: without wire end ferrule, tin-plated; 4-pin
short circuit resistant / Protected against polarity reversal / Overload protection

ISO 15552, Series PRA

Accessories

Dimensions

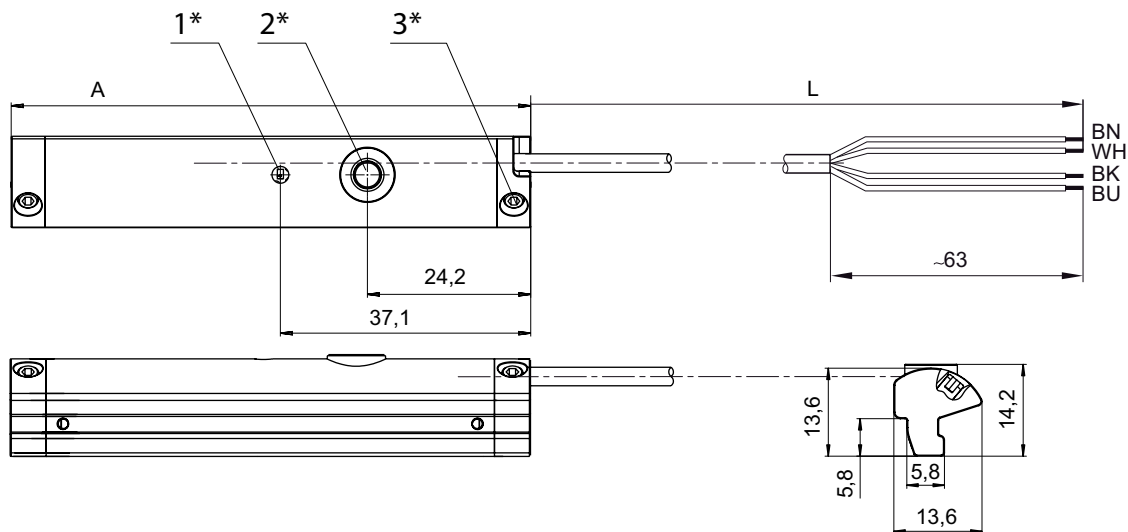

00133787

1* = LED 2* = teach button 3* = threaded pin M3x11

L = cable length

(1) BN=brown

(2) WH=white

(3) BU=blue

(4) BK=black

A = sensor length

Sensors, Series SM6

▶ 6 mm groove ▶ with cable ▶ Plug, M8x1, 4-pin, with knurled screw ▶ with distance measuring sensor, measurement range 32 - 256 mm



00134312

Certificates	cULus
Ambient temperature min./max.	-20°C / +70°C
Protection class	IP67
Output signal	0 - 10 V DC, 4 - 20 mA
Quiescent current (without load)	< 25 mA
Current signal	4 - 20 mA
DC operating voltage min./max.	15 V DC - 30 V DC
sampling interval	1 ms
Resolution max. measuring range	0,05 mm
Repetitive precision max. measuring range	0.1 mm
Linearity deviation	0,3 mm
Sampling speed	3 m/s
Display	LED
LED status display	Yellow
Vibration resistance	10 - 55 Hz, 1 mm
Shock resistance	30 g / 11 ms

Materials:

Housing	Polyamide, fiber-glass reinforced
Cable sheath	Polyurethane

Piston rod cylinders ▶ Standard cylinders

ISO 1552, Series PRA Accessories

	Type of contact	Cable length	Measurement range Max.	Overall length Sensor A	Part No.
		[m]	[mm]	[mm]	
	Analog	0.3	32	45	R412010142
			64	77	R412010144
			96	109	R412010263
			128	141	R412010265
			160	173	R412010410
			192	205	R412010412
			224	237	R412010414
			256	269	R412010416
interfaces: Plug; M8x1; 4-pin; with knurled screw short circuit resistant / Protected against polarity reversal / Overload protection					

Dimensions

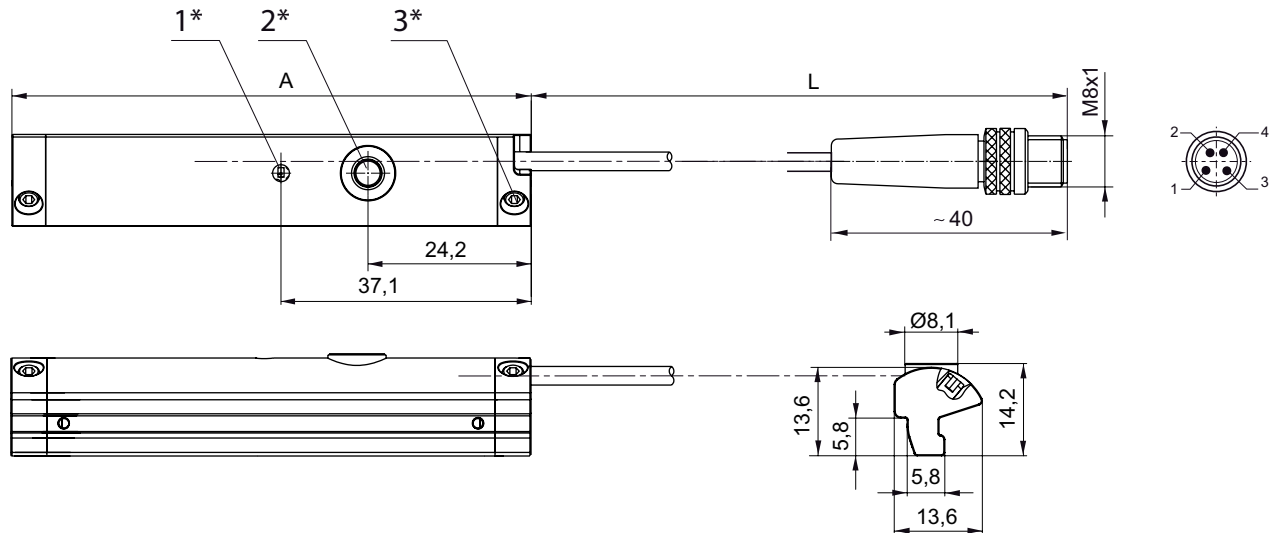

1* = LED 2* = teach button 3* = threaded pin M3x11

L = cable length

Pin assignment: 1 = (+), 2 = (OUT 1) 3 = (GND), 4 = (OUT 2), EN 60947-5-7

A = sensor length

00133788

ISO 15552, Series PRA

Accessories

Sensors, Series SM6-AL

▶ with cable ▶ Plug, M8x1, 4-pin ▶ with distance measuring sensor, measurement range 107 - 1007 mm ▶ IO-Link



18358

Certificates	cULus
Ambient temperature min./max.	-20°C / +70°C
Protection class	IP65, IP67
Output signal	0 - 10 V DC, 4 - 20 mA
Quiescent current (without load)	< 35 mA
Current signal	4 - 20 mA
Maximum load (analog current output)	500 Ω
DC operating voltage min./max.	15 V DC - 30 V DC
Residual ripple	≤ 10 %
sampling interval	1,15 ms
Resolution max. measuring range	typ. 0,03 % FSR
Repetitive precision max. measuring range	typ. 0,06 % FSR
Linearity deviation	0,5 mm
Sampling speed	1,5 m/s
Partial stroke	
Sampling speed	3 m/s
Full stroke	
Display	2 LED
Vibration resistance	10 - 55 Hz, 1 mm
Shock resistance	30 g / 11 ms
Materials:	
Housing	Aluminum
Cable sheath	Polyurethane
End caps	Polyamide

Technical Remarks

- Holders for cylinder series PRA are included in the scope of delivery. For cylinder series ITS, please order the appropriate holders separately.
- FSR: Full Scale Range, max. measurement range
- The IO-Link device description (IODD) for the SM6-AL distance measuring sensor is available for download in the Media Centre.

Piston rod cylinders ▶ Standard cylinders

ISO 15552, Series PRA
Accessories

Type of contact	Cable length	Measurement range Max.	Overall length Sensor A	Incl. number of sensor clamp pairs	Part No.
	[m]	[mm]	[mm]	[piece]	
Analog	0.3	107	109	2	R412010880
		143	145	2	R412010881
		179	181	2	R412010882
		215	217	2	R412010883
		251	253	2	R412010884
		287	289	3	R412010885
		323	325	3	R412010886
		359	361	3	R412010887
		395	397	3	R412010888
		431	433	3	R412010889
		467	469	4	R412010890
		503	505	4	R412010891
		539	541	4	R412010892
		575	577	4	R412010893
		611	613	4	R412010894
		647	649	4	R412010895
		683	685	5	R412010896
		719	721	5	R412010897
		755	757	5	R412010898
		791	793	5	R412010899
827	829	6	R412010900		
863	865	6	R412010901		
899	901	6	R412010902		
935	937	6	R412010903		
971	973	6	R412010904		
1007	1009	6	R412010905		

interfaces: Plug; M8x1; 4-pin
short circuit resistant / Protected against polarity reversal / Overload protection

ISO 15552, Series PRA

Accessories

Dimensions

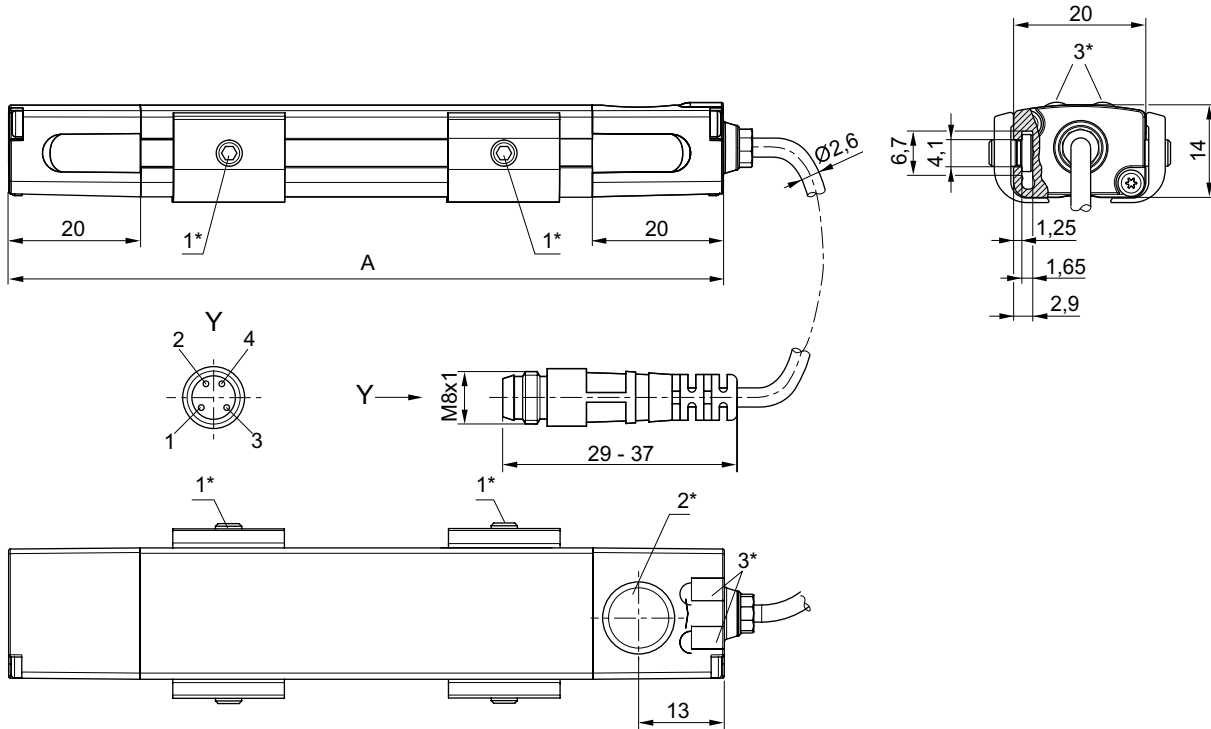

16407

1* = threaded pin M3x11 2* = teach area 3* = LED

A = sensor length

Pin assignment: 1 = (+), 2 = (OUT 1) 3 = (GND), 4 = (OUT 2/IO-Link), EN 60947-5-7

LED 1: yellow = measuring operation, red = error

LED 2: green = voltage signal, blue = current signal

Sensor, Series SN3

▶ Plug, M12, 3-pin ▶ welding-proof



00118461

Ambient temperature min./max.
Protection class
Switching point precision [mm]
Nominal current, actuated state
Quiescent current (without load)
LED status display
Vibration resistance
Shock resistance

-25 °C / +70 °C
IP67, IP65
±0,1
≤ 10 mA
≤ 5 mA
Yellow
55 Hz, 1 mm
30 g / 11 ms

Materials:
Housing

Polyamide

Piston rod cylinders ▶ Standard cylinders

ISO 1552, Series PRA
Accessories

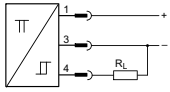
	Type of contact	Voltage drop U at I _{max}	DC switching current, max. [A]	Max. switching frequency kHz	Part No.
	electronic PNP	≤ 1,8 V	0.2	0,02	0830100438
interfaces: Plug; M12; 3-pin short circuit resistant / Protected against polarity reversal					

Dimensions

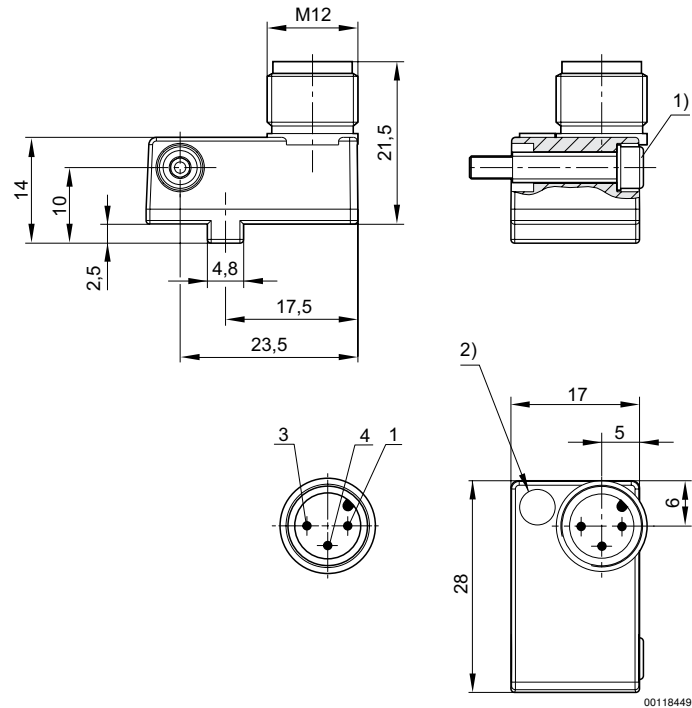

- 1) Clamping screw
 - 2) LED
- Pin assignments: 1 = (+), 3 = (-), 4 = (OUT), EN 60947-5-2:1998

ISO 15552, Series PRA Accessories

Sensor, Series IN1 ▶ for locking unit, series LU6



00136289

Standardization	DIN EN 60947-5-2
Certification	cULus
Ambient temperature min./max.	-20 / 65 °C
Protection class	IP67
Hysteresis	5 - 15%, adjustable
Temperature drift	± 10 %
Residual ripple	≤ 10 %
Reproducibility	≤ 2 %
Switching logic	NO (make contact)
LED status display	Yellow
Materials:	
Housing	Brass

Technical Remarks

- Flush installation
- Switching states: 1. Pressure applied to locking unit, clamping pliers are open, sensor does not emit a signal (normally open) 2. No pressure applied to locking unit, clamping pliers are closed, sensor emits a signal (feedback that LU6 is clamping)

Operational voltage [V DC]	Switching distance max.	Power consumption [mA]	Continuous current [A]	Part No.
10 / 30	2 mm	10	0.2	R412010426

short circuit resistant / Protected against polarity reversal

Dimensions

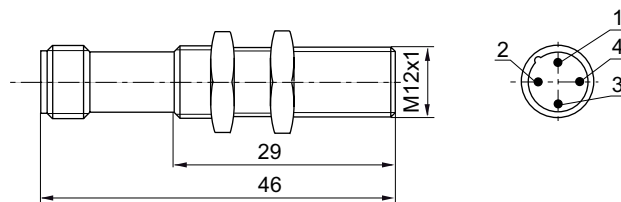

00136658

2) not assigned

Piston rod cylinders ▶ Standard cylinders

ISO 15552, Series PRA
Accessories

Sensor mounting, Series CB1

▶ for Series SN1, SN2 ▶ to mount on cylinder PRA

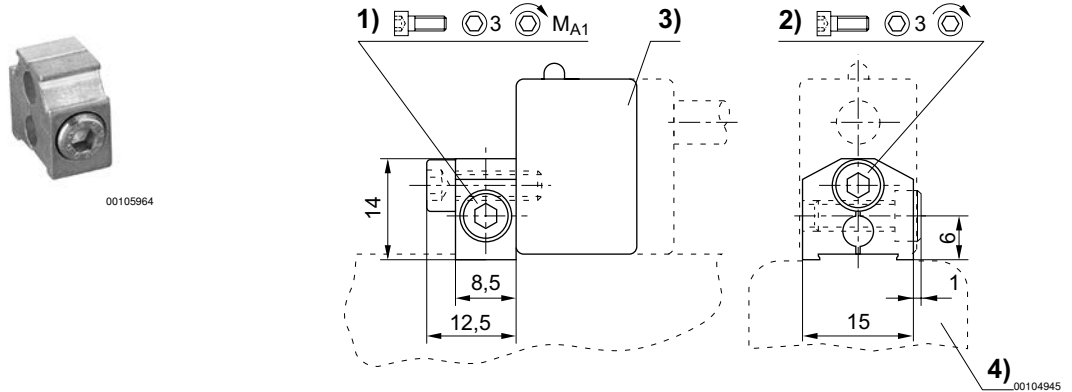

1) Clamping screw 2) Mounting screw for sensor 3) Sensor 4) Cylinder profile

Part No.	For series	1)	MA1 [Nm]	Material	Weight [kg]				
1827020084	SN1, SN2	M4x12	2	Aluminum	0.006				

Sensor mounting, Series CB1

▶ for Series ST6, SM6 ▶ to mount on cylinder TRB, C12P, 167, CVI, TRR, 523

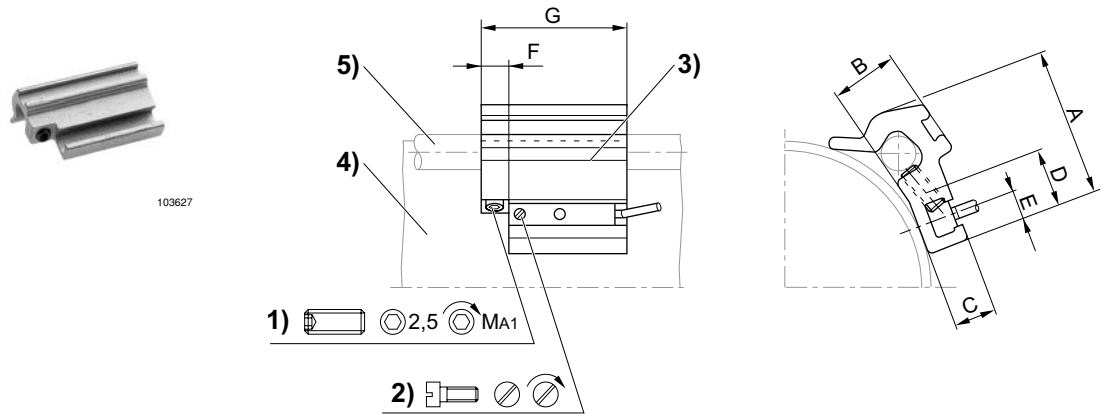

1) Clamping threaded pin 2) Mounting screw for sensor 3) Sensor 4) Cylinder profile 5) Tie rod

Part No.	Cylinders Ø [mm]	For series	A	B	C	D	E	F	G	1)	MA1 [Nm]
1827020282	32 - 40	ST6, SM6	26	10	7	14	5	8	40	M5x8	2 ±0,2
1827020283	50 - 63	ST6, SM6	32.5	15.5	7	14	5	8	40	M5x10	2 ±0,2
1827020284	80 - 100	ST6, SM6	43	17	6.9	14	5	8	40	M5x16	2 ±0,2

Part No.	Material	Weight [kg]								
1827020282	Aluminum	0.016								
1827020283	Aluminum	0.029								
1827020284	Aluminum	0.042								

ISO 15552, Series PRA

Accessories

Sensor mounting, Series CB1

▶ for Series SN3 ▶ to mount on cylinder PRA, KPZ, GPC, CCI, KHZ



00112453

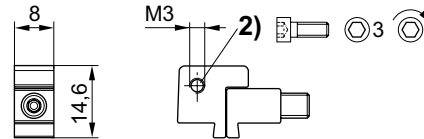
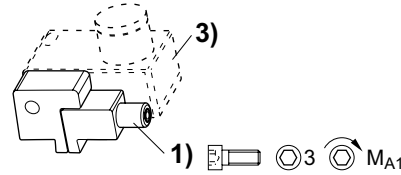

00122794

1) Clamping screw 2) Mounting screw for sensor 3) Sensor

Part No.	For series	1)	MA1 [Nm]	Material	Weight [kg]			
1827020386	SN3	M3x25	1,8 +0,4	Aluminum	0.007			

Connecting cable, Series CN2

▶ Socket, M8, 3-pin, straight ▶ open cable ends, 3-pin

Ambient temperature min./max.
Protection class

-40°C / +85°C
IP65

Materials:
Cable sheath

Polyurethane



00107009_b

Technical Remarks

- The specified protection class is only valid in assembled and tested state.

Max. current	Number of wires	Wire cross-section	Cable-Ø	Cable length L	Weight	Part No.
[A]		[mm ²]	[mm]	[m]	[kg]	
4	3	0.24	4.5	3	0.091	1834484166
				5	0.145	1834484168
				10	0.33	1834484247

Piston rod cylinders ▶ Standard cylinders

ISO 1552, Series PRA
Accessories

Dimensions

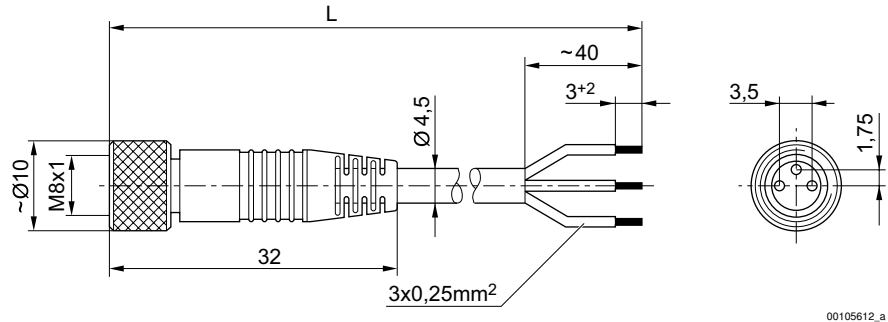

L = length

Pin assignment

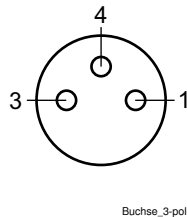

- (1) BN=brown
- (3) BU=blue
- (4) BK=black

Connecting cable, Series CN2

▶ Socket, M8x1, 3-pin, angled ▶ open cable ends, 3-pin



00107009_c

Ambient temperature min./max.
Protection class

-40 °C / +85 °C
IP65

Materials:
Cable sheath

Polyurethane

Technical Remarks

- The specified protection class is only valid in assembled and tested state.

ISO 15552, Series PRA Accessories

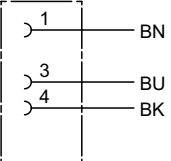
	Max. current	Number of wires	Wire cross-section	Cable-Ø	Cable length L	Weight	Part No.
	[A]		[mm ²]	[mm]	[m]	[kg]	
	4	3	0.24	4.5	3	0.092	1834484167
					5	0.141	1834484169
					10	0.276	1834484248

Dimensions

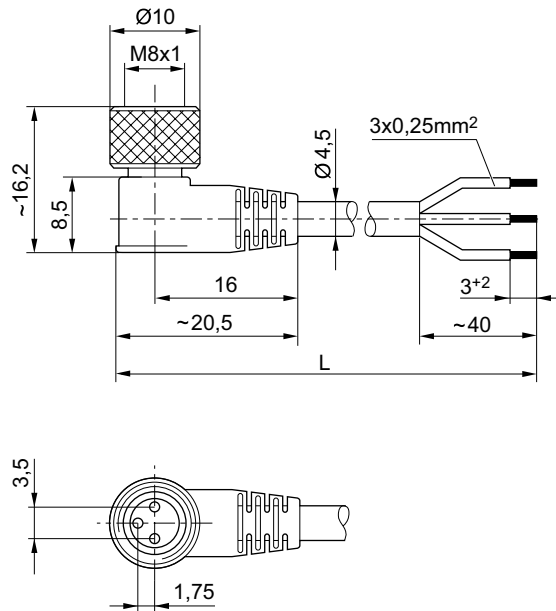

00105612_b

L = length

Pin assignment

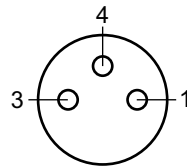

Buchse_3-polig

- (1) BN=brown
- (3) BU=blue
- (4) BK=black

Piston rod cylinders ▶ Standard cylinders

ISO 15552, Series PRA
Accessories

Connecting cable, Series CN2

▶ Socket, M12x1, 5-pin, A-coded, angled ▶ without wire end ferrule, tin-plated, 4-pin ▶ for CANopen, DeviceNet



00107009_c

Ambient temperature min./max. -40°C / +85°C
 Protection class IP65
 Materials:
 Cable sheath Polyurethane

Technical Remarks
 ■ The specified protection class is only valid in assembled and tested state.

	Operational voltage max.	Max. current	Number of wires	Wire cross-section	Cable length L	Weight	Part No.										
	[V AC]	[A]		[mm ²]	[m]	[kg]											
<table border="1"> <tr><td>1</td><td>BN</td></tr> <tr><td>2</td><td>WH</td></tr> <tr><td>3</td><td>BU</td></tr> <tr><td>4</td><td>BK</td></tr> <tr><td>5</td><td></td></tr> </table>	1	BN	2	WH	3	BU	4	BK	5		48	4	4	0.34	3	0.13	1834484259
1	BN																
2	WH																
3	BU																
4	BK																
5																	
5	0.202	1834484260															
10	0.387	1834484261															

Dimensions

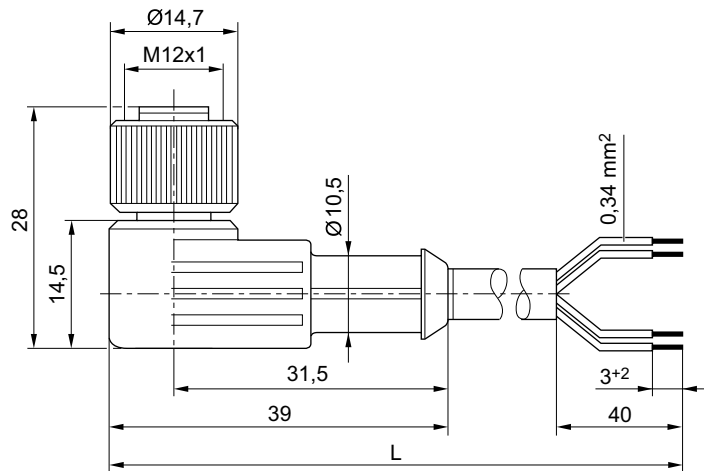

00107205_b

L = length

ISO 15552, Series PRA

Accessories

Pin assignment

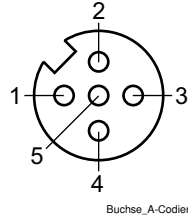

- (1) BN=brown
- (2) WH=white
- (3) BU=blue
- (4) BK=black
- (5) not assigned

Socket, M8x1, Series CN2

▶ Socket, M8x1, 3-pin



00138877

Ambient temperature min./max.
Protection class

-25°C / +80°C
IP67

Materials:
Housing

Polyamide

Technical Remarks

- The specified protection class is only valid in assembled and tested state.

	Operational voltage	Max. current	Cable exit	suitable cable-Ø min./max	number of plug options 1	Housing color	Part No.
	AC						
	[V]	[A]		[mm]			
	48	4	straight	3.5 / 5	1 position	Black	1834484173

Part No.	Weight
	[kg]
1834484173	0.008

Piston rod cylinders ▶ Standard cylinders

ISO 1552, Series PRA
Accessories

Dimensions

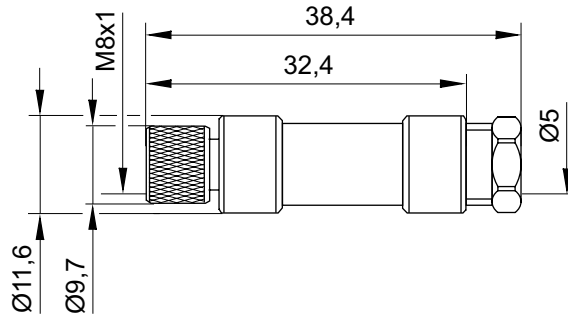

16405

Pin assignment

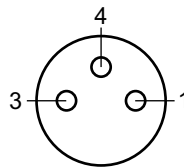

Buchse_3-polig

Socket, M8x1, Series CN2
▶ Socket, M8x1, 3-pin, angled



16406

Ambient temperature min./max.

-25°C / +85°C

Protection class

IP65

Materials:

Housing

Polyamide

Technical Remarks

- The specified protection class is only valid in assembled and tested state.

ISO 15552, Series PRA
 Accessories

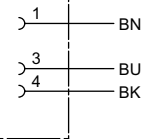
	Operational voltage	Max. current	Contact assignment	Cable exit	suitable cable-Ø min./max	number of plug options ¹	Part No.
	AC						
	[V]	[A]			[mm]		
	48	4	3	angled 90°	3.5 / 5	1 position	1834484174

Part No.	Housing color	Weight
		[kg]
1834484174	Black	0.008

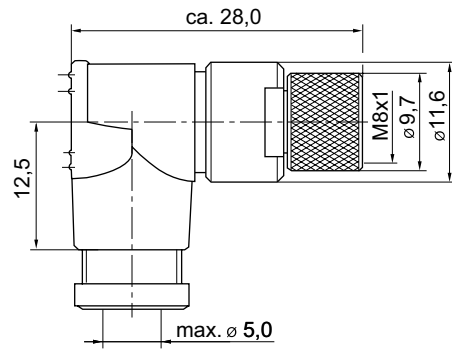
Dimensions

15832

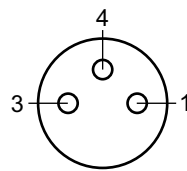
Pin assignment

Buchse_3-polig

Piston rod cylinders ▶ Standard cylinders

ISO 1552, Series PRA
Accessories

Silencers, Series SI1
▶ Sintered bronze



P100_060

Working pressure min./max.	0 bar / 10 bar
Ambient temperature min./max.	-25°C / +80°C
Medium	Compressed air
Materials:	Sintered bronze
Silencers	Brass
Thread	

Compressed air connection	Sound pressure level	Qn	Order quantity	Weight	Part No.
	[dB]	[l/min]	[piece]	[kg]	
G 1/8	75	1500	10	0.01	1827000000
G 1/4	79	2900	10	0.02	1827000001
G 3/8	84	5900	5	0.05	1827000002
G 1/2	90	7100	2	0.08	1827000003

Dimensions

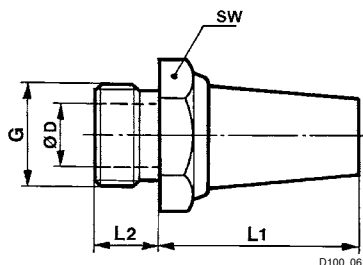

Part No.	Port G	SW	Ø D	L1	L2							
1827000000	G 1/8	13	6	18	6							
1827000001	G 1/4	17	8.5	25	8							
1827000002	G 3/8	22	12	34	10							
1827000003	G 1/2	27	14.5	44	12							

Sound pressure level measured at 6 bar at 1 m distance

ISO 1552, Series PRA
 Accessories

Silencers, Series SI1
 ▶ Sintered bronze

P100_037

Working pressure min./max. 0 bar / 10 bar
 Ambient temperature min./max. -25°C / +80°C
 Medium Compressed air

Materials:
 Silencers Sintered bronze
 Thread Brass

Compressed air connection	Sound pressure level	Qn	Order quantity	Weight	Part No.
	[dB]	[l/min]	[piece]	[kg]	
G 1/8	85	640	10	0.001	1827000031
G 1/4	88	900	10	0.01	1827000033
G 3/8	90	1750	5	0.016	1827000034
G 1/2	85	2000	2	0.035	1827000035

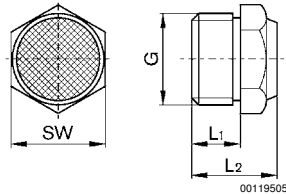
Dimensions

Part No.	Port G	L1	L2	SW								
1827000031	G 1/8	6	11.5	13								
1827000033	G 1/4	8	13.5	17								
1827000034	G 3/8	10	17.5	22								
1827000035	G 1/2	12	19.5	27								

Sound pressure level measured at 6 bar at 1 m distance

AVENTICS GmbH
Ulmer Straße 4
30880 Laatzen, GERMANY
Phone +49 511 2136-0
Fax +49 511 2136-269
www.aventics.com
info@aventics.com



Find more contact information at
www.aventics.com/contact

Only use the AVENTICS products shown in industrial applications. Read the product documentation completely and carefully before using the product.

Observe the applicable regulations and laws of the respective country. When integrating the product into applications, note the system manufacturer's specifications for safe use of the product.

The data specified only serve to describe the product.

No statements concerning a certain condition or suitability for a certain application can be derived from our information.

The information given does not release the user from the obligation of own judgment and verification. It must be remembered that the products are subject to a natural process of wear and aging.

02-05-2017

An example configuration is depicted on the title page. The delivered product may thus vary from that in the illustration. Subject to change. © AVENTICS S.à r.l.
This document, as well as the data, specifications and other information set forth in it, are the exclusive property of AVENTICS S.à r.l.. It may not be reproduced or given to third parties without its consent. PDF online