

2 Finger, 3 Finger, 4 Finger Parallel Type Air Gripper

Series MHS

ø16, ø20, ø25, ø32, ø40, ø50, ø63, ø80, ø100, ø125

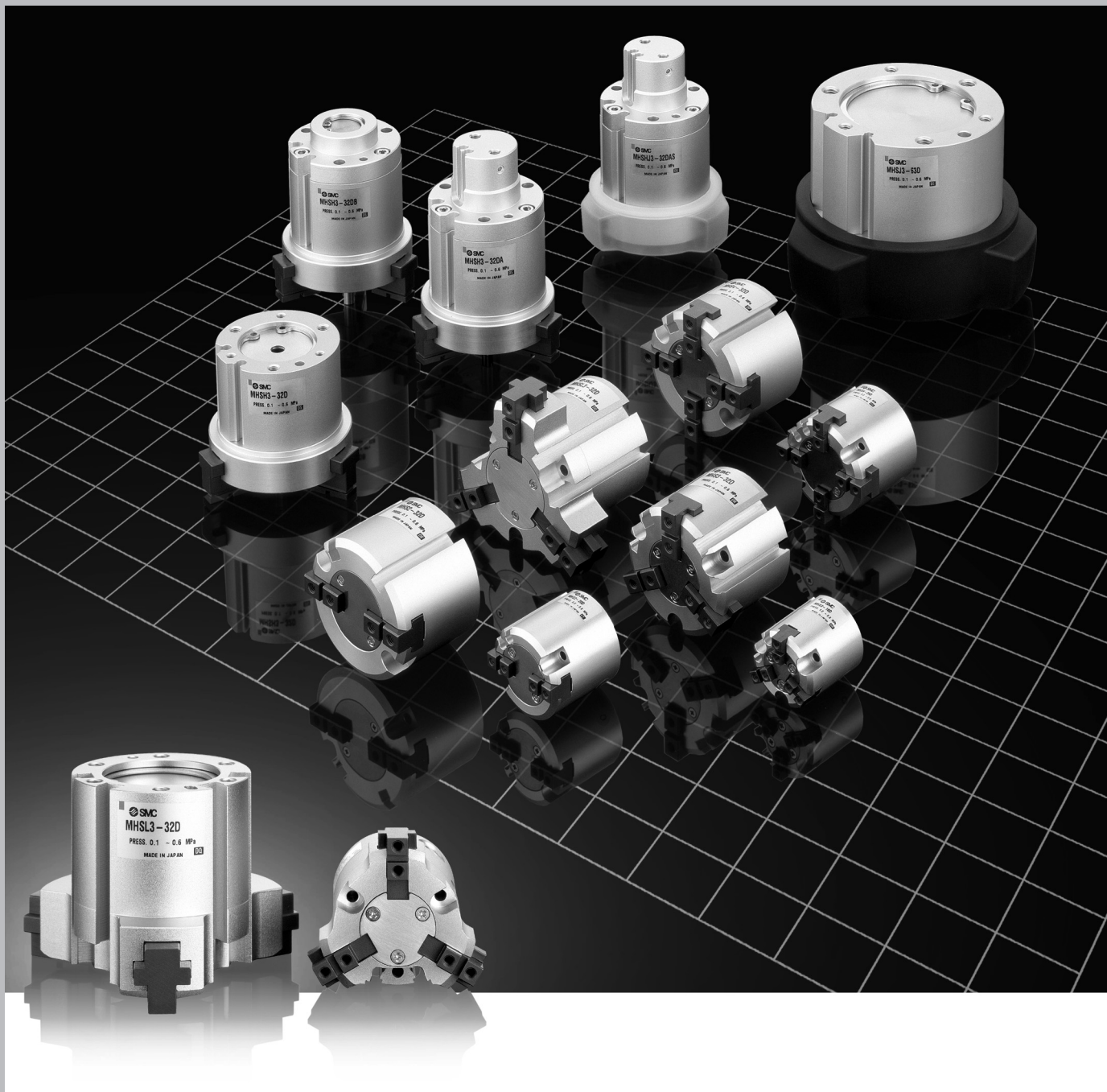

Lightweight, compact design with reduced height

Long stroke (MHSL3) introduced to upgraded series.

High repeatability: $\pm 0.01\text{mm}$

Auto switch capable

A wide variety of solid state auto switches can be mounted using the body's side mounting grooves. Selections include 2 colour indication and water resistant types.

Easy alignment when mounting

Positioning pin holes are provided on the top of the gripper.

Can be mounted from two directions

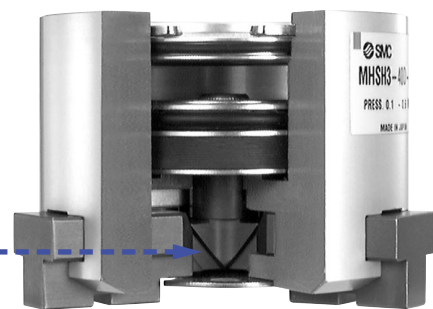
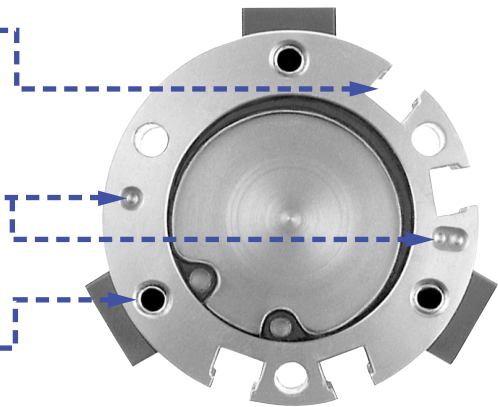
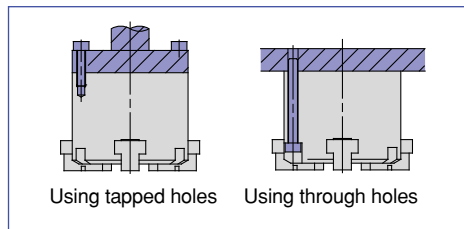

Employs wedge cam construction

The wedge cam mechanism allows strong gripping force to be obtained from a compact design.

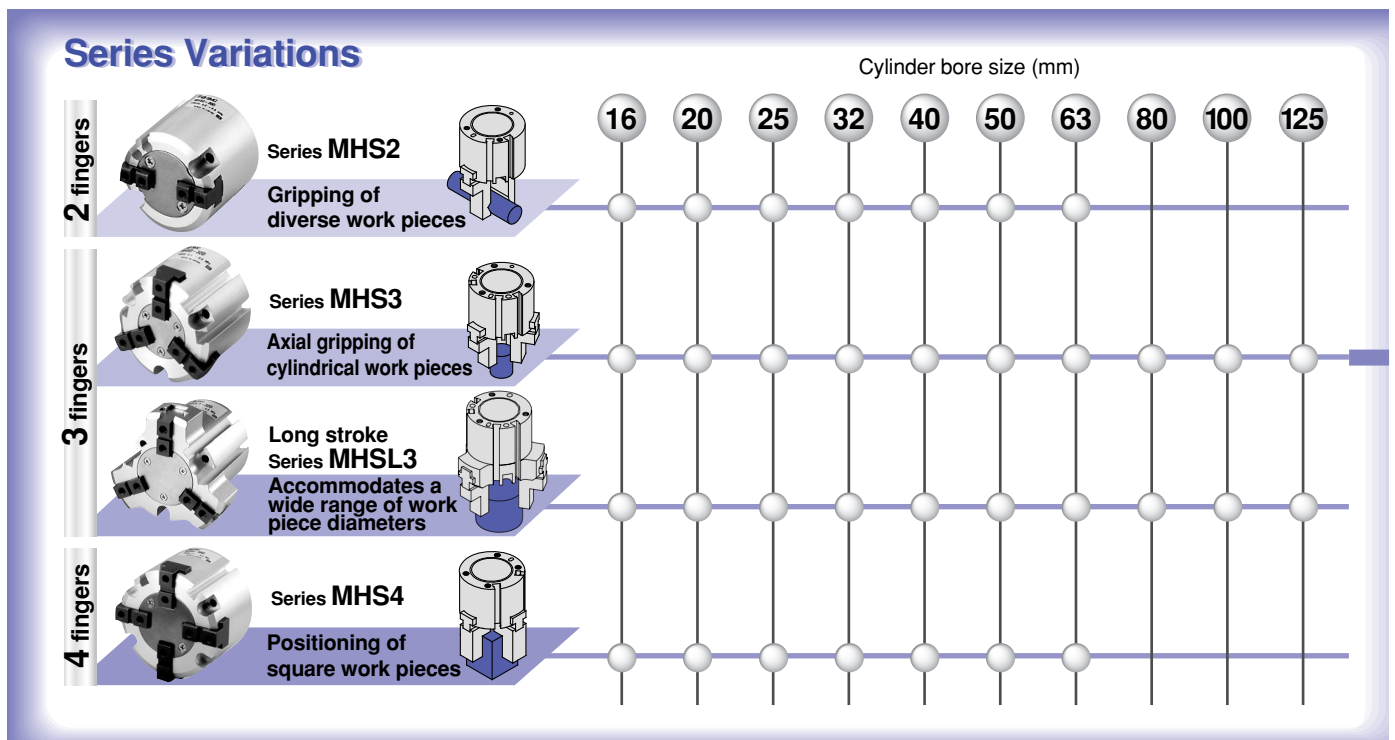

Ideal for gripping work pieces of different diameters.

Long Stroke **MHSL3**

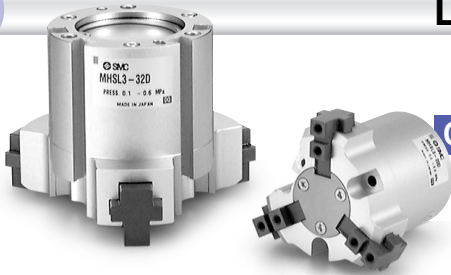

Opening/closing stroke more than twice the standard (MHS3)

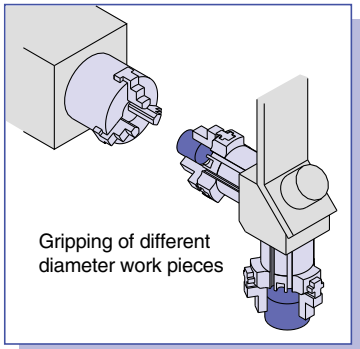

Cylinder bore size mm	Stroke mm	Height mm	Weight g
	Dia.: Open - Closed		
16	10 (4)	43.5	80
	10 (4)		
20	12 (6)	46	135
	16 (8)		
25	20 (8)	49	180
	20 (8)		
32	28 (12)	58	370
	28 (12)		
40	32 (16)	64	550
	32 (16)		
50	40 (20)	77.5	930
	40 (20)		
63	48 (24)	89	1,550
	48 (24)		
80	64 (32)	116	2,850
	64 (32)		
100		135	5,500
125		175	11,300

Standard inside () /MHS3 stroke

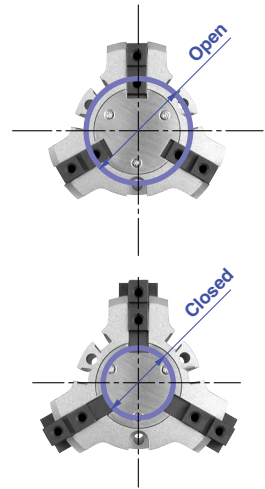

- The mounting pitch is compatible with the standard type.

MHS3 Variations

With dust cover/MHSJ3



		Cylinder bore size (mm)							
		16	20	25	32	40	50	63	80
MHSJ3	With dust cover	•	•	•	•	•	•	•	•
MHS3	Through hole	•	•	•	•	•	•	•	•
	With centre pusher (cylinder type)	•	•	•	•	•	•	•	•
	With centre pusher (spring type)	•	•	•	•	•	•	•	•
MHSJ3	Through hole with dust cover	•	•	•	•	•	•	•	•
	With dust cover/centre pusher (cylinder type)	•	•	•	•	•	•	•	•
	With dust cover/centre pusher (spring type)	•	•	•	•	•	•	•	•

Through hole/MHSH3

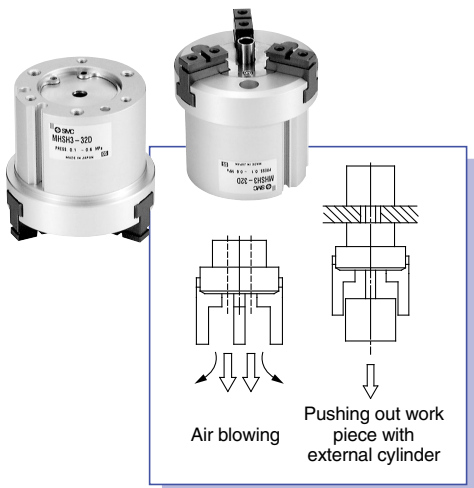

With dust cover/centre pusher



The dust cover and centre pusher assembly can be modularized for the through hole MHS3.

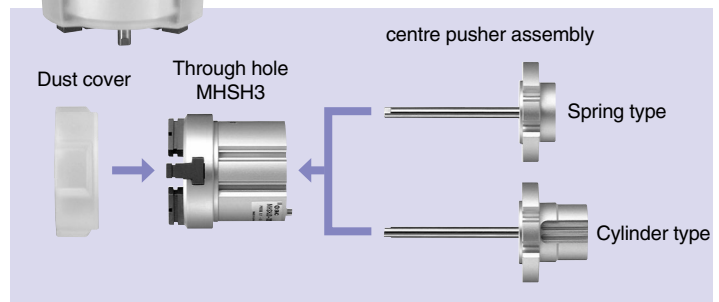

2 Finger Air Gripper Parallel Type

Series MHS2

ø16, ø20, ø25, ø32, ø40, ø50, ø63

How to Order

Cylinder Bore Size

ø16 to ø25 **MHS 2 - 20 D - M9N**

Number of fingers
2 | 2 fingers

Cylinder bore size
16 | 16mm
20 | 20mm
25 | 25mm

Action
D | Double acting

Number of auto switches
Nil | 2 pcs.
S | 1 pc.

Auto switch type
Nil | Without auto switch (built-in magnet)

Applicable Auto Switches

Type	Special function	Electrical entry	Indicator light	Wiring (Output)	Load voltage		Auto switch model		Lead wire length (m)*				Pre-wired connector	Applicable load	
					DC	AC	Electrical entry direction		0.5 (Nil)	1 (M)	3 (L)	5 (Z)			
							Perpendicular	In-line							
Solid state auto switch	—	Grommet	Yes	3-wire(NPN)	24 V	5 V, 12 V	—	M9NV	M9N	●	●	●	○	○	Relay, PLC
				3-wire(PNP)				M9PV	M9P	●	●	●	○	○	
				2-wire				M9BV	M9B	●	●	●	○	○	
				3-wire(NPN)				M9NVW	M9NW	●	●	●	○	○	
				3-wire(PNP)				M9PVW	M9PW	●	●	●	○	○	
				2-wire				M9BWW	M9BW	●	●	●	○	○	
	Diagnosis (2-colour indication)	Grommet	Yes	3-wire(NPN)	24 V	5 V, 12 V	—	M9NAV**	M9NA**	○	○	●	○	○	Relay, PLC
				3-wire(PNP)				M9PAV**	M9PA**	○	○	●	○	○	
				2-wire				M9BAV**	M9BA**	○	○	●	○	○	
				3-wire(NPN)				M9NV	M9N	●	●	●	○	○	
				3-wire(PNP)				M9PV	M9P	●	●	●	○	○	
				2-wire				M9BV	M9B	●	●	●	○	○	
Water resistant (2-colour indication)	Grommet	Yes	3-wire(NPN)	24 V	5 V, 12 V	—	M9NAV**	M9NA**	○	○	●	○	○	Relay, PLC	
			3-wire(PNP)				M9PAV**	M9PA**	○	○	●	○	○		
			2-wire				M9BAV**	M9BA**	○	○	●	○	○		
			3-wire(NPN)				M9NV	M9N	●	●	●	○	○		
			3-wire(PNP)				M9PV	M9P	●	●	●	○	○		
			2-wire				M9BV	M9B	●	●	●	○	○		

** Water resistant type auto switches can be mounted on the above models, but in such case SMC cannot guarantee water resistance.

* Lead wire length symbols: 0.5 m Nil (Example) M9NW
1 m M (Example) M9NWM
3 m L (Example) M9NWL
5 m Z (Example) M9NWZ

* Auto switches marked with a "○" symbol are produced upon receipt of order.

Note 1) When using the 2-colour indicator type, please make the setting so that the indicator is lit in red to ensure the detection at the proper position of the air gripper.

Cylinder Bore Size

ø32 to ø63 **MHS 2 - 50 D - M9N**

Number of fingers
2 | 2 fingers

Cylinder bore size
32 | 32mm
40 | 40mm
50 | 50mm
63 | 63mm

Action
D | Double acting

Number of auto switches
Nil | 2 pcs.
S | 1 pc.

Auto switch type
Nil | Without auto switch (built-in magnet)

Symbol

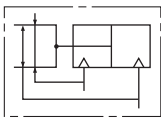

Applicable Auto Switches

Type	Special function	Electrical entry	Indicator light	Wiring (Output)	Load voltage		Auto switch model		Lead wire length (m)*				Pre-wired connector	Applicable load	
					DC	AC	Electrical entry direction		0.5 (Nil)	1 (M)	3 (L)	5 (Z)			
							Perpendicular	In-line							
Solid state auto switch	—	Grommet	Yes	3-wire(NPN)	24 V	5 V, 12 V	—	M9NV	M9N	●	●	●	○	○	Relay, PLC
				3-wire(PNP)				M9PV	M9P	●	●	●	○	○	
				2-wire				M9BV	M9B	●	●	●	○	○	
				3-wire(NPN)				M9NVW	M9NW	●	●	●	○	○	
				3-wire(PNP)				M9PVW	M9PW	●	●	●	○	○	
				2-wire				M9BWW	M9BW	●	●	●	○	○	
	Diagnosis (2-colour indication)	Grommet	Yes	3-wire(NPN)	24 V	5 V, 12 V	—	M9NAV**	M9NA**	○	○	●	○	○	Relay, PLC
				3-wire(PNP)				M9PAV**	M9PA**	○	○	●	○	○	
				2-wire				M9BAV**	M9BA**	○	○	●	○	○	
				3-wire(NPN)				M9NV	M9N	●	●	●	○	○	
				3-wire(PNP)				M9PV	M9P	●	●	●	○	○	
				2-wire				M9BV	M9B	●	●	●	○	○	
Water resistant (2-colour indication)	Grommet	Yes	3-wire(NPN)	24 V	5 V, 12 V	—	M9NAV**	M9NA**	○	○	●	○	○	Relay, PLC	
			3-wire(PNP)				M9PAV**	M9PA**	○	○	●	○	○		
			2-wire				M9BAV**	M9BA**	○	○	●	○	○		
			3-wire(NPN)				M9NV	M9N	●	●	●	○	○		
			3-wire(PNP)				M9PV	M9P	●	●	●	○	○		
			2-wire				M9BV	M9B	●	●	●	○	○		

** Water resistant type auto switches can be mounted on the above models, but in such case SMC cannot guarantee water resistance.

* Lead wire length symbols: 0.5 m Nil (Example) M9NW
1 m M (Example) M9NWM
3 m L (Example) M9NWL
5 m Z (Example) M9NWZ

* Auto switches marked with a "○" symbol are produced upon receipt of order.

Note 1) When using the 2-colour indicator type, please make the setting so that the indicator is lit in red to ensure the detection at the proper position of the air gripper.

Note 2) When ordering the air gripper with the auto switch, the auto switch mounting bracket is included.

When ordering the auto switch separately, the auto switch mounting bracket (BMG2-012) is required.

Models and Specifications



Model	MHS2-16D	MHS2-20D	MHS2-25D	MHS2-32D	MHS2-40D	MHS2-50D	MHS2-63D	
Cylinder bore size mm	16	20	25	32	40	50	63	
Fluid	Air							
Operating pressure MPa	0.2 to 0.6			0.1 to 0.6				
Ambient and fluid temperature °C	-10 to 60							
Repeatability mm	±0.01							
Max. operating frequency c.p.m.	120			60				
Lubrication	Non-lube							
Action	Double acting							
Effective gripping force ^{Note 1)} N at pressure of 0.5MPa	External gripping force	21	37	63	111	177	280	502
	Internal gripping force	23	42	71	123	195	306	537
Opening/closing stroke (both sides) mm	4	4	6	8	8	12	16	
Weight g	58	96	134	265	345	515	952	

Note) Values for $\phi 16$ to $\phi 25$ are with gripping point L = 20mm, and for $\phi 32$ to $\phi 63$ with gripping point L = 30mm.
Refer to the "Effective Gripping Force" data on pages 5-162 and 5-163 for the gripping force at each gripping position.

Construction

Closed condition

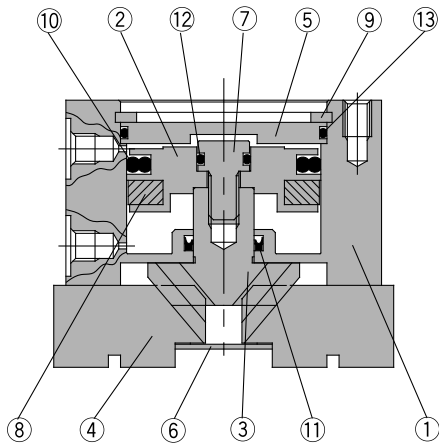

Open condition

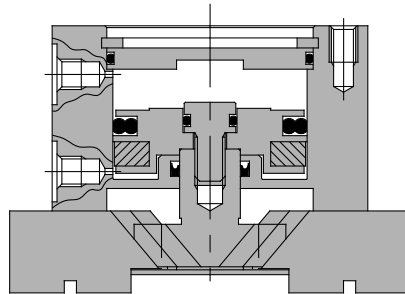

Parts list

No.	Description	Material	Note
1	Body	Aluminum alloy	Hard anodized
2	Piston	Aluminum alloy	Hard anodized
3	Cam	Carbon steel	Heat treated, Specially treated
4	Finger	Carbon steel	Heat treated, Specially treated
5	Cap	Aluminum alloy	Hard anodized
6	End plate	Stainless steel	
7	Piston bolt	Stainless steel	

No.	Description	Material	Note
8	Rubber magnet	Synthetic rubber	
9	C type snap ring	Carbon steel	Nickel plated
10	Piston seal	NBR	
11	Rod seal	NBR	
12	Gasket	NBR	
13	Gasket	NBR	

Replacement parts/Seal kits

Kit number							Contents
MHS2-16D	MHS2-20D	MHS2-25D	MHS2-32D	MHS2-40D	MHS2-50D	MHS2-63D	
MHS16-PS	MHS20-PS	MHS25-PS	MHS32-PS	MHS40-PS	MHS50-PS	MHS63-PS	A set of the above Nos. 10, 11, 12 and 13

* Seal kits are sets consisting of items 10, 11, 12 and 13, which can be ordered using the kit number for each cylinder bore size.

Series MHS2

Gripping Point

- The work piece gripping point distance should be within the gripping force ranges given for each pressure in the effective gripping force graphs below.
- If operated with the work piece gripping point beyond the indicated ranges, an excessive offset load will be applied to the sliding section of the fingers, which can have an adverse effect on the service life of the product.

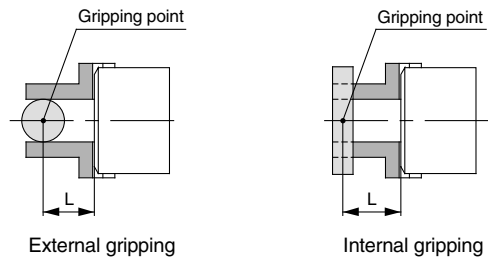

L: Gripping point distance

Effective Gripping Force

- Expressing the effective gripping force
The effective gripping force shown in the graphs to the right is expressed as F, which is the impellent force of one finger when both of the fingers and attachments are in full contact with the work piece as shown in the figure below.

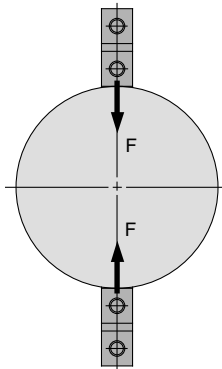

External gripping

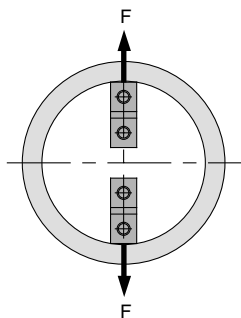

Internal gripping

1N: Approx. 0.102kgf
1MPa: Approx. 10.2kgf/cm²

External gripping force

MHS2-16D

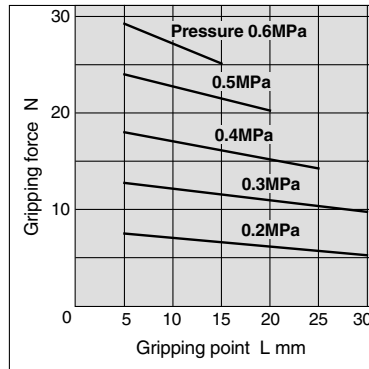

MHS2-20D

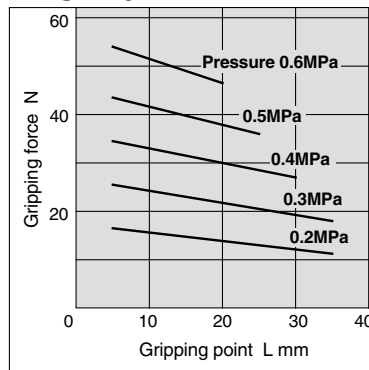

MHS2-25D

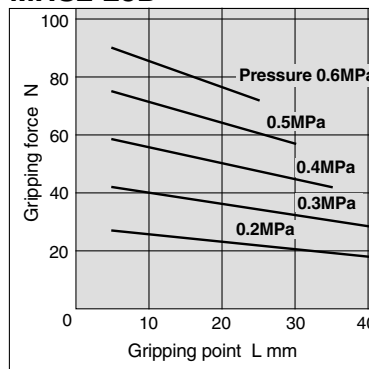

Internal gripping force

MHS2-16D

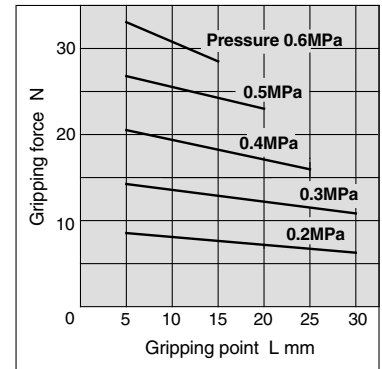

MHS2-20D

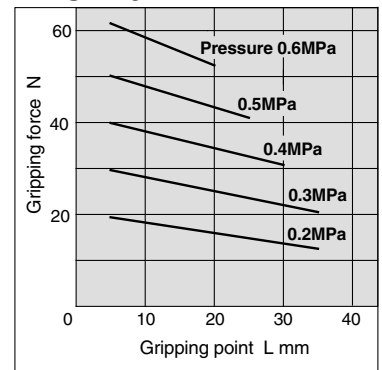

MHS2-25D

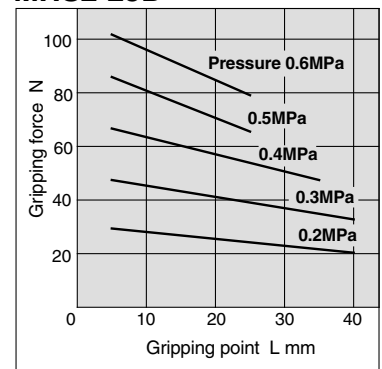

Effective Gripping Force

- Expressing the effective gripping force
The effective gripping force shown in the graphs to the right is expressed as F, which is the impellent force of one finger when both of the fingers and attachments are in full contact with the work piece as shown in the figure below.

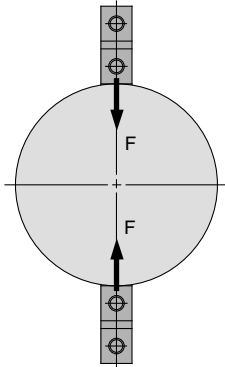

External gripping

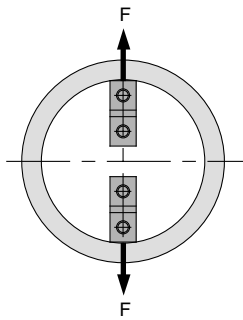

Internal gripping

1N: Approx. 0.102kgf
1MPa: Approx. 10.2kgf/cm²

External gripping force

MHS2-32 D

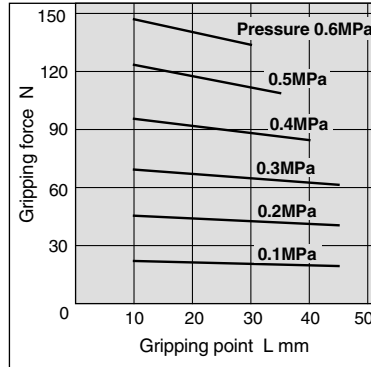

MHS2-40 D

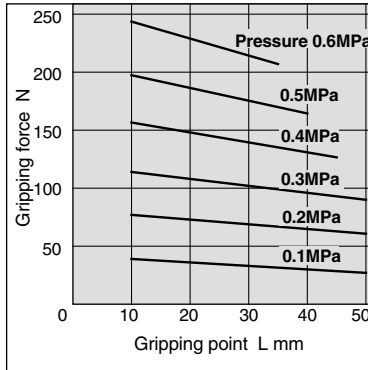

MHS2-50 D

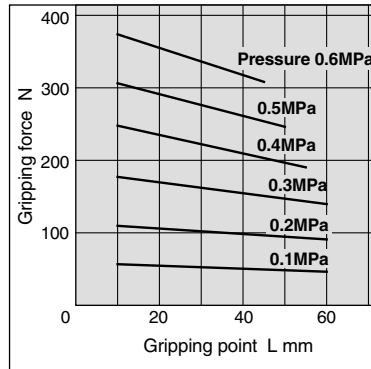

MHS2-63 D

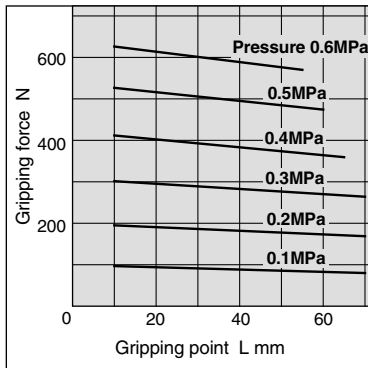

Internal gripping force

MHS2-32 D

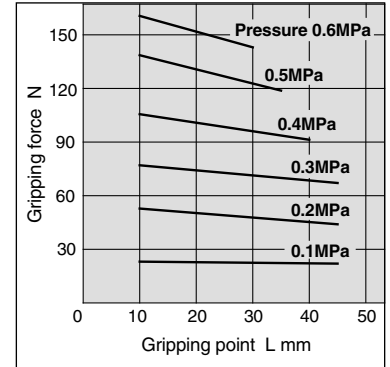

MHS2-40 D

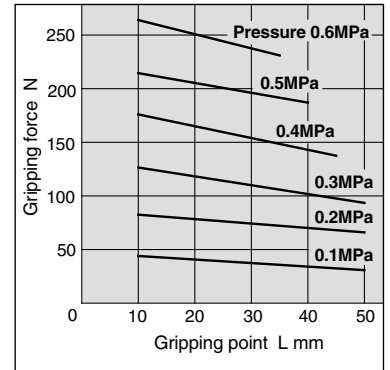

MHS2-50 D

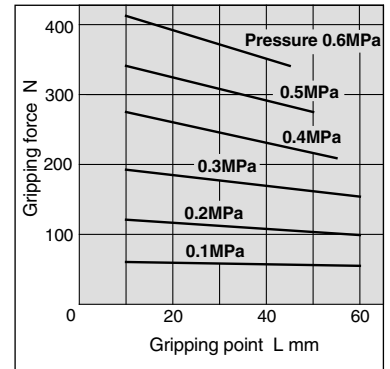

MHS2-63 D

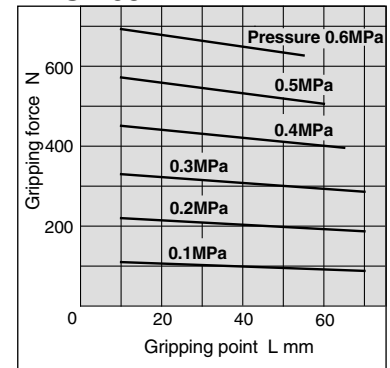

Series MHS2

Dimensions

MHS2-16D to 25D

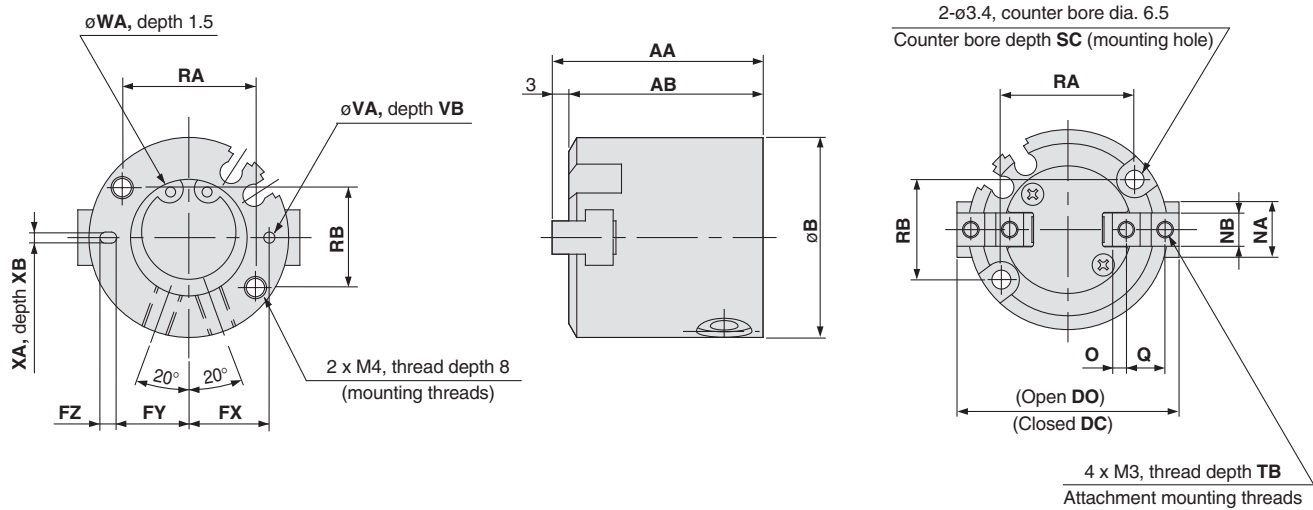
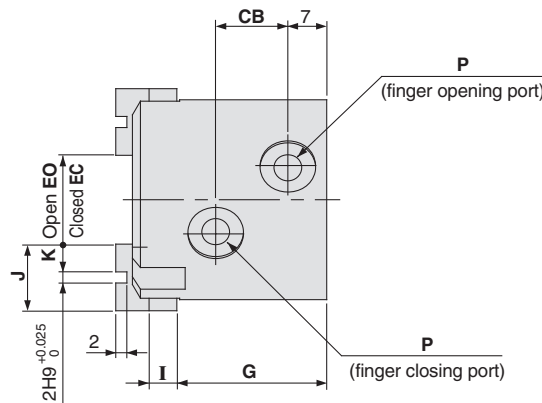

Auto switch mounting groove positions (2 locations)

MHS2-16D

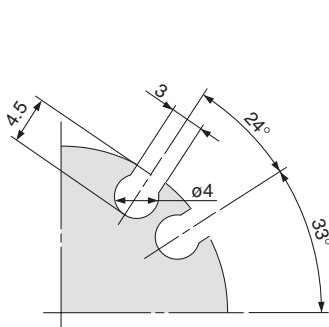

MHS2-20D

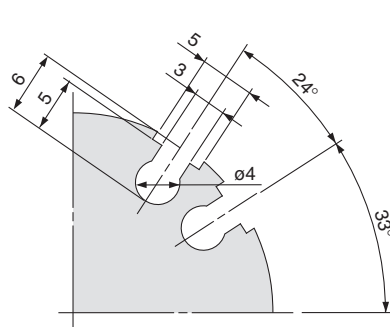

MHS2-25D

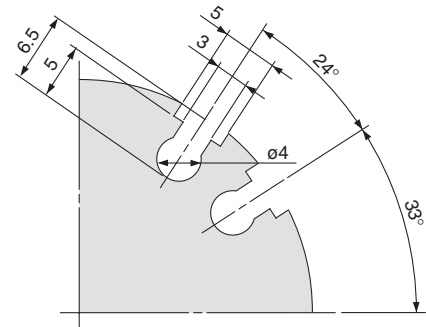

Model	AA	AB	B	CB	DC	DO	EC	EO	FX	FY	FZ	G	I	J	K	NA	NB	O	P	Q
MHS2-16D	35	32	30	11	30	34	10	14	12.5	11	3	25	4	10	4	8	5h9 ₀ ⁰ _{-0.030}	2	M3	6
MHS2-20D	38	35	36	13	36	40	12	16	14.5	13	3	27	5	12	5	10	6h9 ₀ ⁰ _{-0.030}	2.5	M5	7
MHS2-25D	40	37	42	15	42	48	14	20	17	14.5	5	28	5	14	6	12	6h9 ₀ ⁰ _{-0.030}	3	M5	8

Model	RA	RB	SC	TB	VA	VB	WA	XA	XB
MHS2-16D	18	16	8	5	2H9 ₀ ^{+0.025}	2	17H9 ₀ ^{+0.043}	2H9 ₀ ^{+0.025}	2
MHS2-20D	24	18	9.5	6	2H9 ₀ ^{+0.025}	2	21H9 ₀ ^{+0.052}	2H9 ₀ ^{+0.025}	2
MHS2-25D	26	22	10	6	3H9 ₀ ^{+0.025}	3	26H9 ₀ ^{+0.052}	3H9 ₀ ^{+0.025}	3

MHS2-32D, 40D

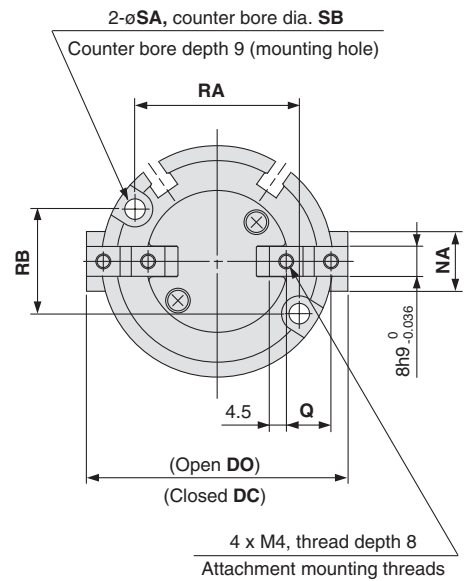
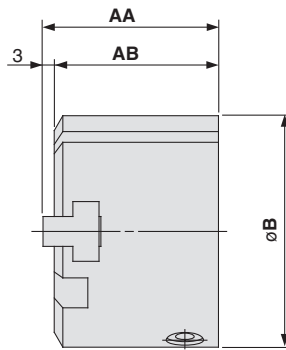
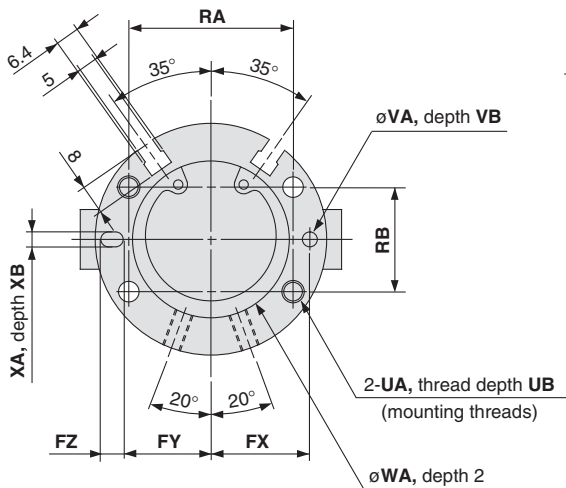
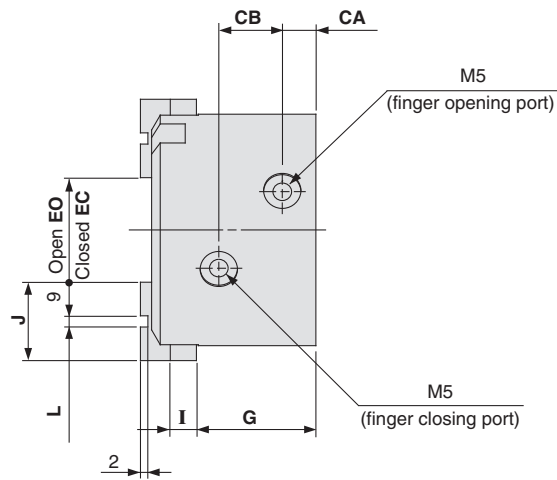

Model	AA	AB	B	CA	CB	DC	DO	EC	EO	FX	FY	FZ	G	I	J	L	NA	Q	RA	RB	SA
MHS2-32D	44	41	56	8	16	56	64	16	24	23	20.5	5	30.5	6	20	2H9 ^{+0.025} ₀	14	11	38	25	4.5
MHS2-40D	47	44	62	9	17	62	70	20	28	26.5	23.5	6	32	7	21	3H9 ^{+0.025} ₀	16	12	44	28	5.5

Model	SB	UA	UB	VA	VB	WA	XA	XB
MHS2-32D	8	M5	10	3H9 ^{+0.025} ₀	3	34H9 ^{+0.062} ₀	3H9 ^{+0.025} ₀	3
MHS2-40D	9.5	M6	12	4H9 ^{+0.030} ₀	4	42H9 ^{+0.062} ₀	4H9 ^{+0.030} ₀	4

Series MHS2

Dimensions

MHS2-50D, 63D

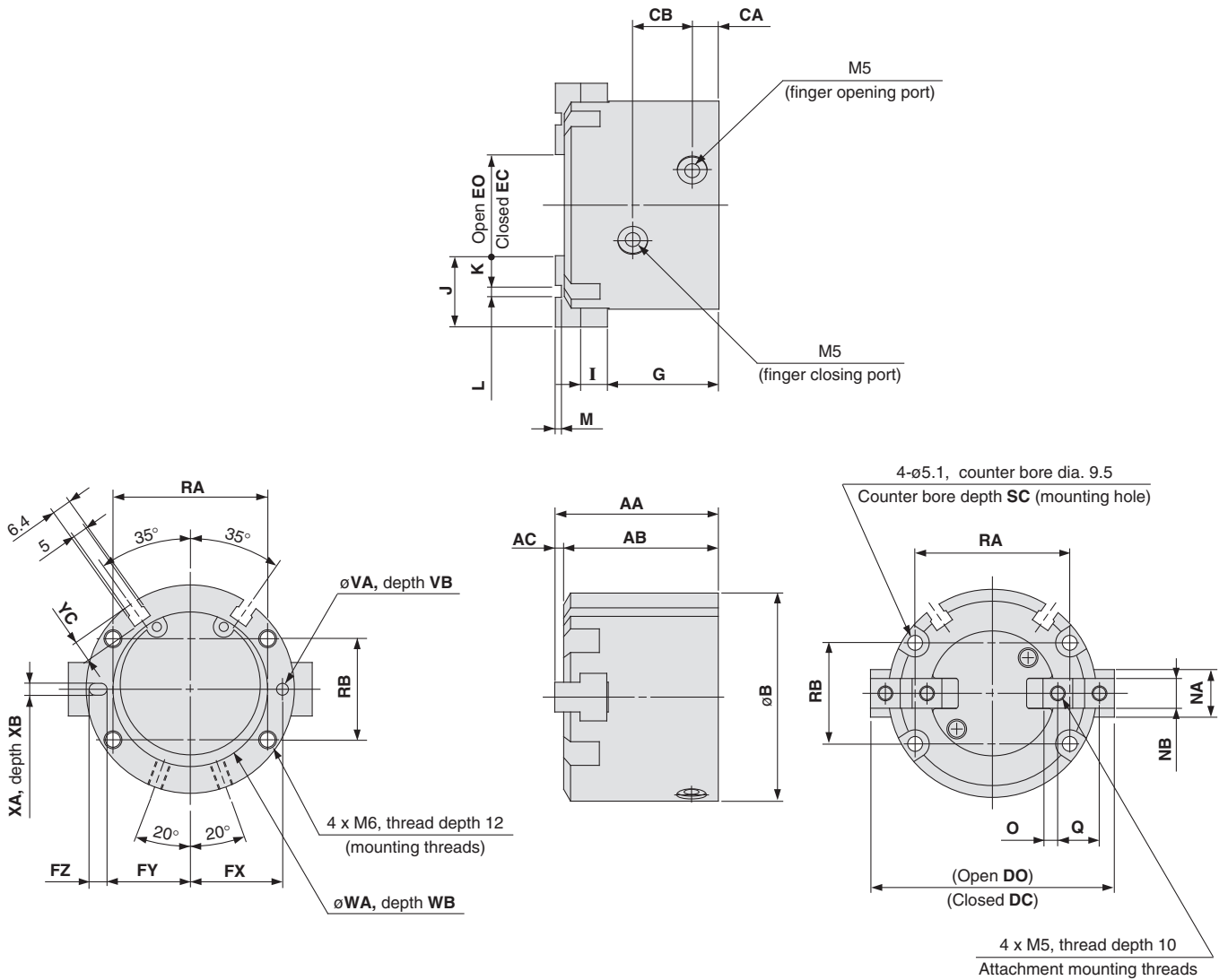

(mm)

Model	AA	AB	AC	B	CA	CB	DC	DO	EC	EO	FX	FY	FZ	G	I	J	K	L	M	NA	NB
MHS2-50D	55	52	3	70	9	20	70	82	22	34	31	28	6	37.5	9	24	10	4H9 ^{+0.030} ₀	2	18	10h9 ₀ ^{-0.036}
MHS2-63D	66	62	4	86	12	22	86	102	30	46	38	34.5	7	44	11	28	11	6H9 ^{+0.030} ₀	3	24	12h9 ₀ ^{-0.043}
Model	O	Q	RA	RB	SC	VA	VB	WA	WB	XA	XB	YC									
MHS2-50D	5	14	52	34	12	4H9 ^{+0.030} ₀	4	52H9 ^{+0.074} ₀	2	4H9 ^{+0.030} ₀	4	7									
MHS2-63D	5.5	17	66	38	14	5H9 ^{+0.030} ₀	5	65H9 ^{+0.074} ₀	2.5	5H9 ^{+0.030} ₀	5	7.5									

Series MHS3

ø16, ø20, ø25, ø32, ø40, ø50, ø63, ø80, ø100, ø125

How to Order

Cylinder Bore Size

ø16 to ø25 **MHS 3** — **20** **D** — **M9N**

Number of fingers

3	3 fingers
---	-----------

Cylinder bore size

16	16mm
20	20mm
25	25mm

Number of auto switches

Nil	2 pcs.
S	1 pc.

Auto switch type

Nil	Without auto switch (built-in magnet)
-----	---------------------------------------

Action

D	Double acting
---	---------------

Applicable Auto Switches

Type	Special function	Electrical entry	Indicator light	Wiring (Output)	Load voltage		Auto switch model		Lead wire length (m)*				Pre-wired connector	Applicable load		
					DC	AC	Electrical entry direction		0.5 (Nil)	1 (M)	3 (L)	5 (Z)		IC circuit	Relay, PLC	
							Perpendicular	In-line								
Solid state auto switch	—	Grommet	Yes	3-wire(NPN)	5 V, 12 V	—	M9NV	M9N	●	●	●	○	○	IC circuit	—	
				3-wire(PNP)			M9PV	M9P	●	●	●	○				
				2-wire	M9BV	M9B	●	●	●	○	○					
				3-wire(NPN)	5 V, 12 V	—	M9N WV	M9N W	●	●	●	○	○			IC circuit
				3-wire(PNP)			M9P WV	M9P W	●	●	●	○	○			
				2-wire	M9B WV	M9B W	●	●	●	○	○					
	Diagnosis (2-colour indication)	Grommet	Yes	3-wire(NPN)	5 V, 12 V	—	M9NAV**	M9NA**	○	○	●	○	○	IC circuit	—	
				3-wire(PNP)			M9PAV**	M9PA**	○	○	●	○	○			
				2-wire	M9BAV**	M9BA**	○	○	●	○	○					
				3-wire(NPN)	5 V, 12 V	—	M9NAV**	M9NA**	○	○	●	○	○			IC circuit
				3-wire(PNP)			M9PAV**	M9PA**	○	○	●	○	○			
				2-wire	M9BAV**	M9BA**	○	○	●	○	○					

** Water resistant type auto switches can be mounted on the above models, but in such case SMC cannot guarantee water resistance.
 * Lead wire length symbols: 0.5 m Nil (Example) M9NW
 1 m M (Example) M9NWM
 3 m L (Example) M9NWL
 5 m Z (Example) M9NWX
 * Auto switches marked with a "○" symbol are produced upon receipt of order.

Note 1) When using the 2-colour indicator type, please make the setting so that the indicator is lit in red to ensure the detection at the proper position of the air gripper.

Cylinder Bore Size

ø32 to ø125 **MHS 3** — **50** **D** — **M9N**

Number of fingers

3	3 fingers
---	-----------

Cylinder bore size

32	32mm
40	40mm
50	50mm
63	63mm
80	80mm
100	100mm
125	125mm

Port thread type

Symbol	Type	Size
Nil	M thread	ø32 to ø63
TN	NPT	ø80 to ø125
TF	G	

Number of auto switches

Nil	2 pcs.
S	1 pc.
n	"n" pcs.

Auto switch type

Nil	Without auto switch (built-in magnet)
-----	---------------------------------------

Action

D	Double acting
---	---------------

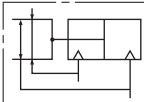
Symbol

Applicable Auto Switches

Type	Special function	Electrical entry	Indicator light	Wiring (Output)	Load voltage		Auto switch model		Lead wire length (m)*				Pre-wired connector	Applicable load		
					DC	AC	Electrical entry direction		0.5 (Nil)	1 (M)	3 (L)	5 (Z)		IC circuit	Relay, PLC	
							Perpendicular	In-line								
Solid state auto switch	—	Grommet	Yes	3-wire(NPN)	5 V, 12 V	—	M9NV	M9N	●	●	●	○	○	IC circuit	—	
				3-wire(PNP)			M9PV	M9P	●	●	●	○	○			
				2-wire	M9BV	M9B	●	●	●	○	○					
				3-wire(NPN)	5 V, 12 V	—	M9N WV	M9N W	●	●	●	○	○			IC circuit
				3-wire(PNP)			M9P WV	M9P W	●	●	●	○	○			
				2-wire	M9B WV	M9B W	●	●	●	○	○					
	Diagnosis (2-colour indication)	Grommet	Yes	3-wire(NPN)	5 V, 12 V	—	M9NAV**	M9NA**	○	○	●	○	○	IC circuit	—	
				3-wire(PNP)			M9PAV**	M9PA**	○	○	●	○	○			
				2-wire	M9BAV**	M9BA**	○	○	●	○	○					
				3-wire(NPN)	5 V, 12 V	—	M9NAV**	M9NA**	○	○	●	○	○			IC circuit
				3-wire(PNP)			M9PAV**	M9PA**	○	○	●	○	○			
				2-wire	M9BAV**	M9BA**	○	○	●	○	○					

** Water resistant type auto switches can be mounted on the above models, but in such case SMC cannot guarantee water resistance.
 * Lead wire length symbols: 0.5 m Nil (Example) M9NW
 1 m M (Example) M9NWM
 3 m L (Example) M9NWL
 5 m Z (Example) M9NWX
 * Auto switches marked with a "○" symbol are produced upon receipt of order.

Note 1) When using the 2-colour indicator type, please make the setting so that the indicator is lit in red to ensure the detection at the proper position of the air gripper.
 Note 2) When ordering the air gripper with the auto switch, the auto switch mounting bracket is included.
 When ordering the auto switch separately, the auto switch mounting bracket (BMG2-012) is required.

Series MHS3

Models and Specifications



Model	MHS3-16D	MHS3-20D	MHS3-25D	MHS3-32D	MHS3-40D	MHS3-50D	MHS3-63D	MHS3-80D	MHS3-100D	MHS3-125D	
Cylinder bore size mm	16	20	25	32	40	50	63	80	100	125	
Fluid	Air										
Operating pressure MPa	0.2 to 0.6					0.1 to 0.6					
Ambient and fluid temperature °C	-10 to 60										
Repeatability mm	±0.01										
Max. operating frequency c.p.m.	120					60			30		
Lubrication	Non-lube										
Action	Double acting										
Effective gripping force N at pressure of 0.5MPa	External gripping force	14	25	42	74	118	187	335	500	750	1,270
	Internal gripping force	16	28	47	82	130	204	359	525	780	1,320
Opening/closing stroke mm (dia.)	4	4	6	8	8	12	16	20	24	32	
Weight g	60	100	140	237	351	541	992	1,850	3,340	6,460	

Note 1) Values for $\phi 16$ to $\phi 25$ are with gripping point L = 20mm, for $\phi 32$ to $\phi 63$ with gripping point L = 30mm, and for $\phi 80$ to $\phi 125$ with gripping point L = 50mm.

Refer to the "Effective Gripping Force" data on pages 5-169 through 5-171 for the gripping force at each gripping position.

Note 2) Open and closed diameter values apply for external gripping of work pieces.

Construction

Closed condition

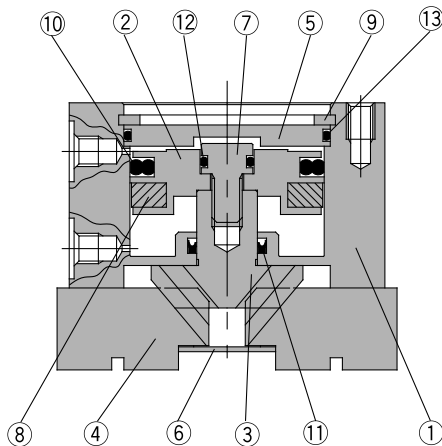

Open condition

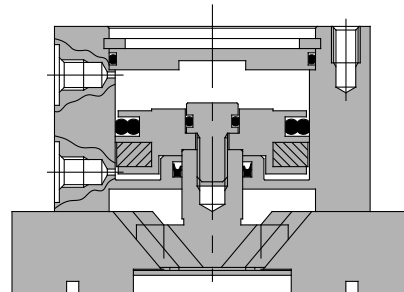

Parts list

No.	Description	Material	Note
1	Body	Aluminum alloy	Hard anodized
2	Piston	Aluminum alloy	Hard anodized
3	Cam	Carbon steel	Heat treated, Specially treated
4	Finger	Carbon steel	Heat treated, Specially treated
5	Cap	Aluminum alloy	Hard anodized
6	End plate	Stainless steel	
7	Piston bolt	Stainless steel	

No.	Description	Material	Note
8	Rubber magnet	Synthetic rubber	
9	C type snap ring	Carbon steel	Nickel plated
10	Piston seal	NBR	
11	Rod seal	NBR	
12	Gasket	NBR	
13	Gasket	NBR	

Replacement parts/Seal kits

Kit number										Contents
MHS3-16D	MHS3-20D	MHS3-25D	MHS3-32D	MHS3-40D	MHS3-50D	MHS3-63D	MHS3-80D	MHS3-100D	MHS3-125D	
MHS16-PS	MHS20-PS	MHS25-PS	MHS32-PS	MHS40-PS	MHS50-PS	MHS63-PS	MHS80-PS	MHS100-PS	MHS125-PS	A set of the above Nos. 10, 11, 12 and 13

* Seal kits are sets consisting of items 10, 11, 12 and 13, which can be ordered using the kit number for each cylinder bore size.

Gripping Point

- The work piece gripping point distance should be within the gripping force ranges given for each pressure in the effective gripping force graphs below.
- If operated with the work piece gripping point beyond the indicated ranges, an excessive offset load will be applied to the sliding section of the fingers, which can have an adverse effect on the service life of the product.

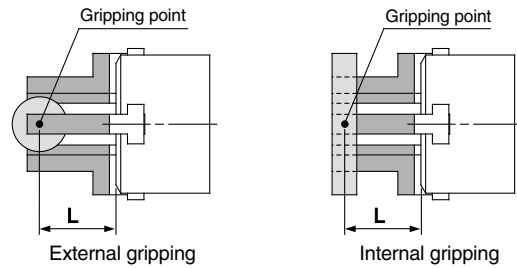

L: Gripping point distance

Effective Gripping Force

- Expressing the effective gripping force
The effective gripping force shown in the graphs to the right is expressed as F, which is the impellent force of one finger when all 3 of the fingers and attachments are in full contact with the work piece as shown in the figure below.

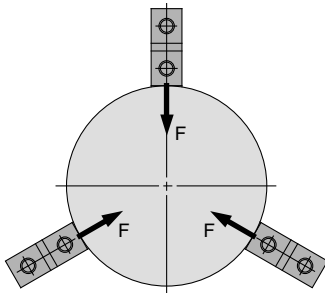

External gripping

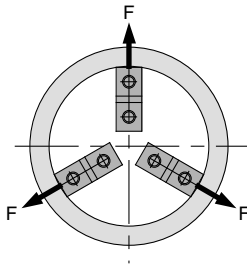

Internal gripping

1N: Approx. 0.102kgf
1MPa: Approx. 10.2kgf/cm²

External gripping force

MHS3-16D

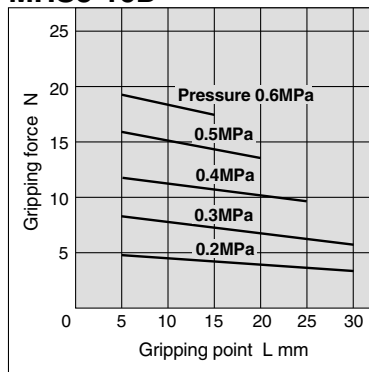

MHS3-20D

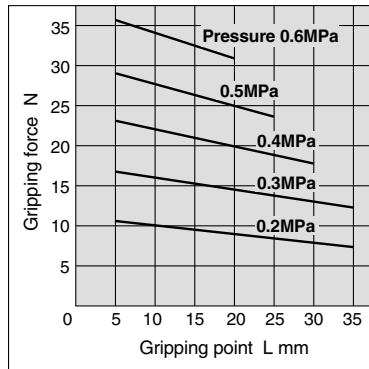

MHS3-25D

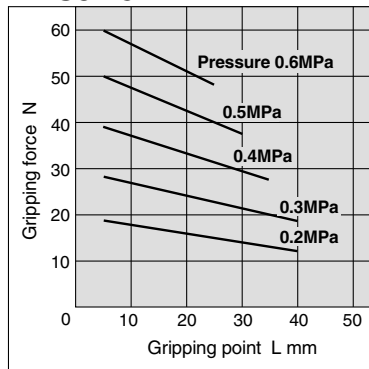

Internal gripping force

MHS3-16D

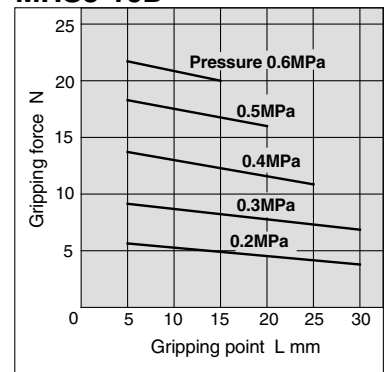

MHS3-20D

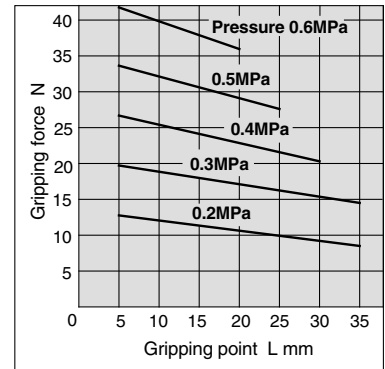

MHS3-25D

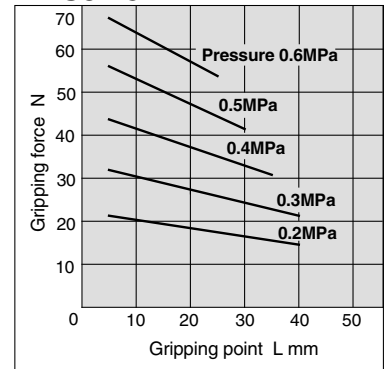

Series MHS3

Effective Gripping Force

- Expressing the effective gripping force

The effective gripping force shown in the graphs to the right is expressed as F, which is the impellent force of one finger when all 3 of the fingers and attachments are in full contact with the work piece as shown in the figure below.

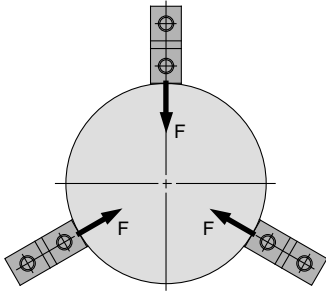

External gripping

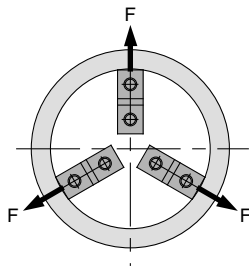

Internal gripping

1N: Approx. 0.102kgf
1MPa: Approx. 10.2kgf/cm²

External gripping force

MHS3-32 D

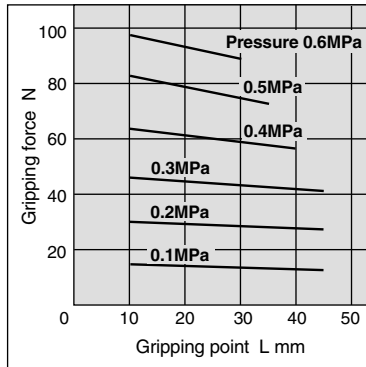

MHS3-40 D

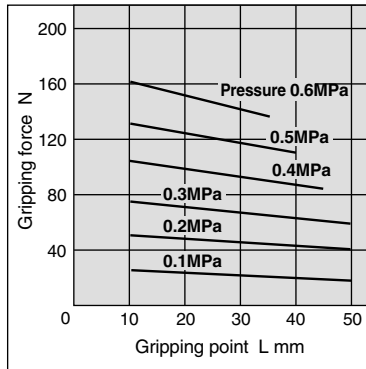

MHS3-50 D

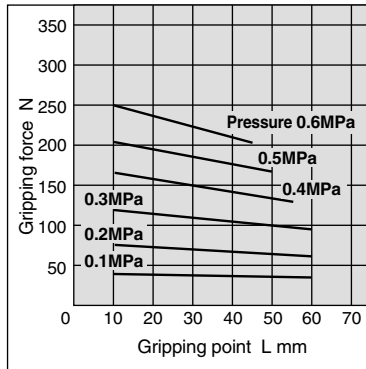

MHS3-63 D

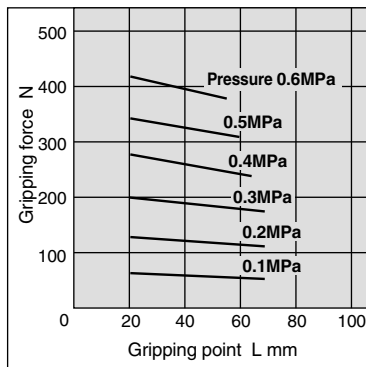

Internal gripping force

MHS3-32 D

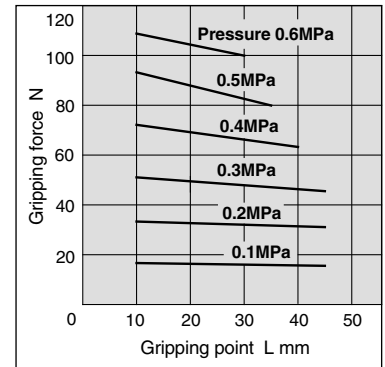

MHS3-40 D

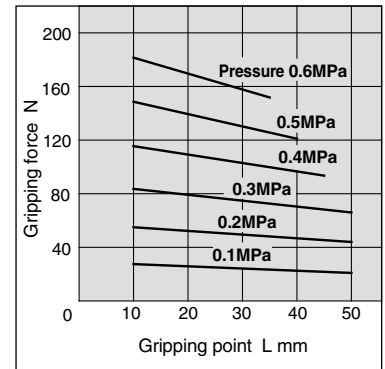

MHS3-50 D

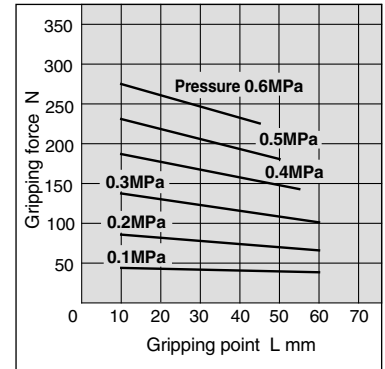

MHS3-63 D

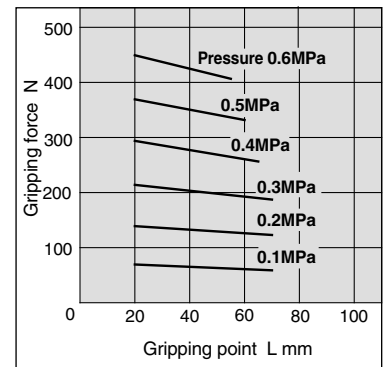

External gripping force

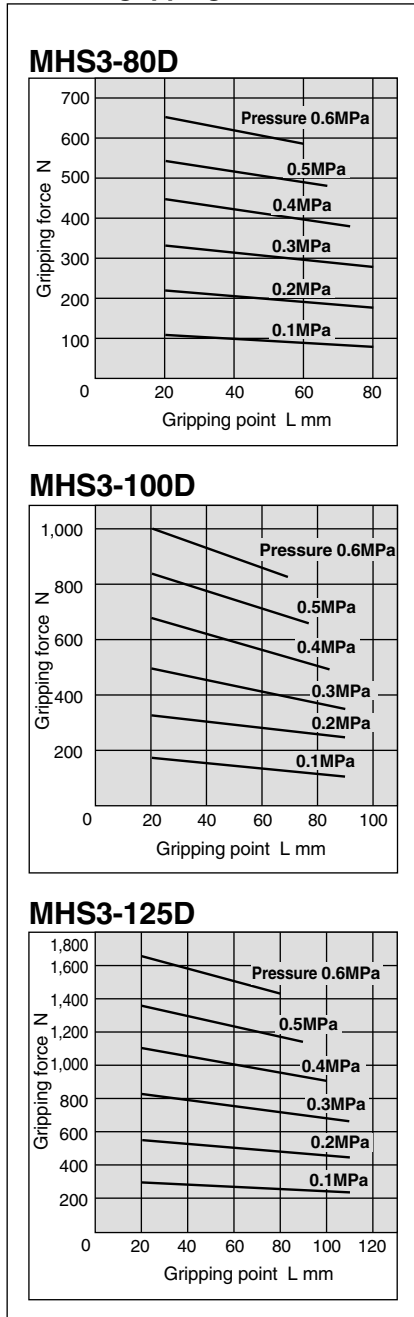

Internal gripping force

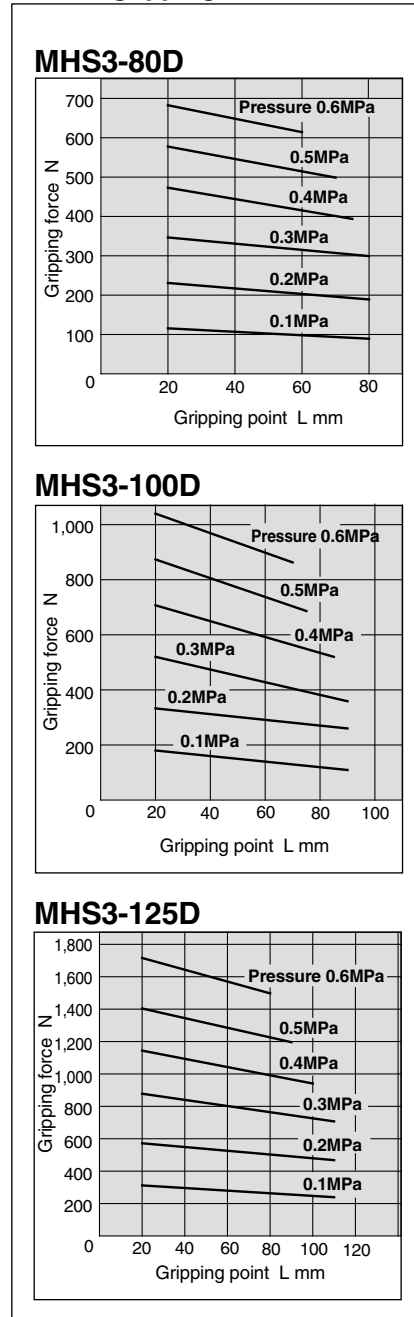

Series MHS3

Dimensions

MHS3-16D to 25D

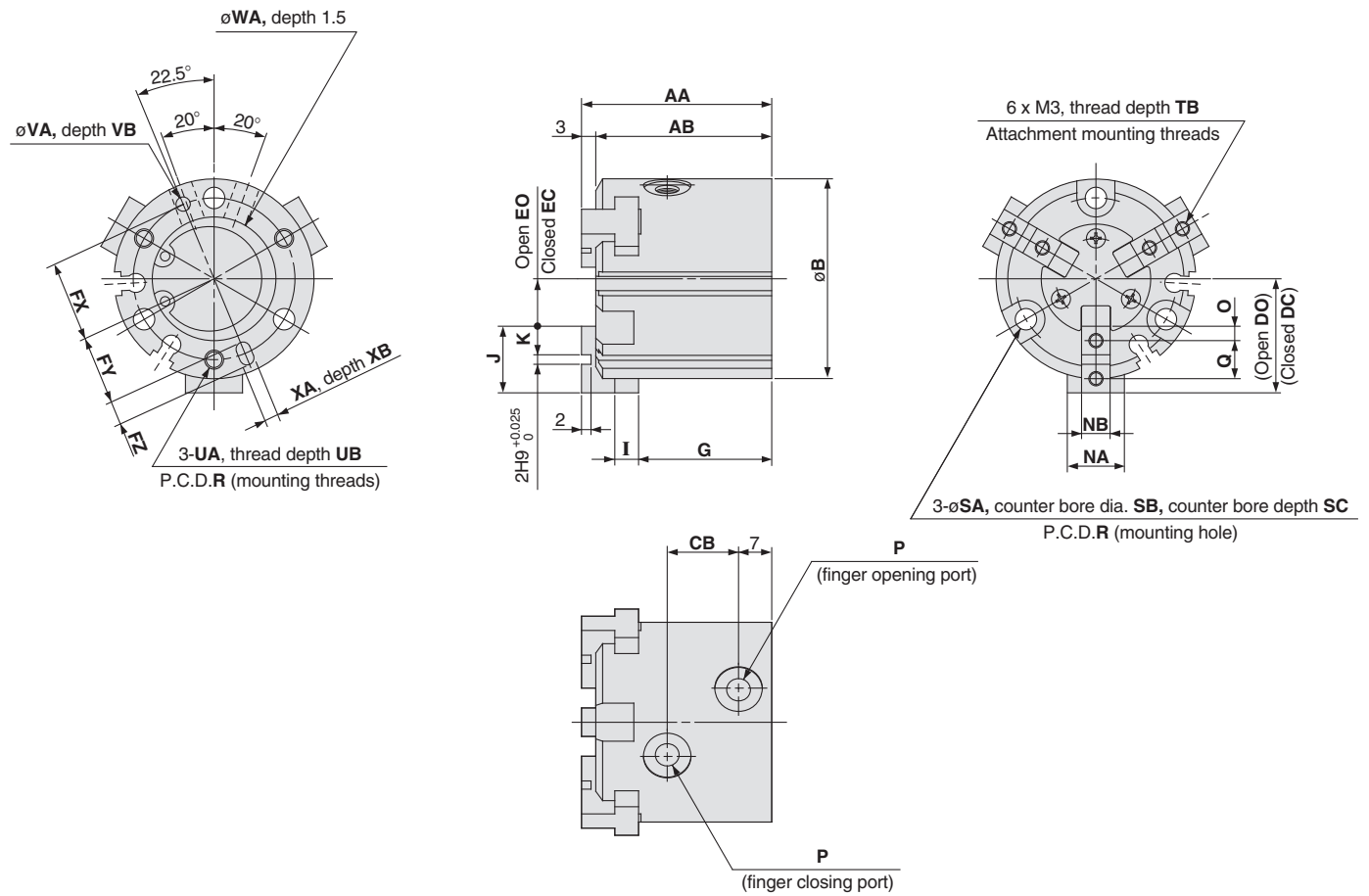

Auto switch mounting groove positions (2 locations)

MHS3-16D

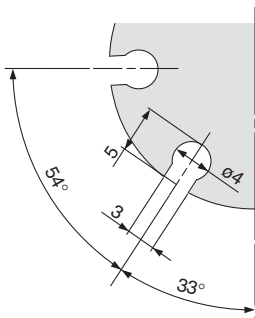

MHS3-20D

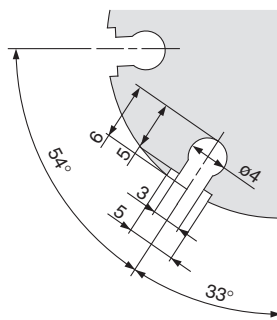

MHS3-25D

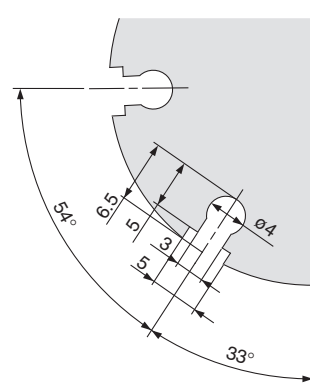

Model	AA	AB	B	CB	DC	DO	EC	EO	FX	FY	FZ	G	I	J	K	NA	NB	O	P	Q	R
MHS3-16D	35	32	30	11	15	17	5	7	12.5	11	3	25	4	10	4	8	5h9 ₀ ⁰ _{-0.030}	2	M3	6	25
MHS3-20D	38	35	36	13	18	20	6	8	14.5	13	3	27	5	12	5	10	6h9 ₀ ⁰ _{-0.030}	2.5	M5	7	29
MHS3-25D	40	37	42	15	21	24	7	10	17	14.5	5	28	5	14	6	12	6h9 ₀ ⁰ _{-0.030}	3	M5	8	34

Model	SA	SB	SC	TB	UA	UB	VA	VB	WA	XA	XB
MHS3-16D	3.4	6.5	8	5	M3	4.5	2H9 ₀ ^{+0.025}	2	17H9 ₀ ^{+0.043}	2H9 ₀ ^{+0.025}	2
MHS3-20D	3.4	6.5	9.5	6	M3	6	2H9 ₀ ^{+0.025}	2	21H9 ₀ ^{+0.052}	2H9 ₀ ^{+0.025}	2
MHS3-25D	4.5	8	10	6	M4	6	3H9 ₀ ^{+0.025}	3	26H9 ₀ ^{+0.052}	3H9 ₀ ^{+0.025}	3

Series MHS3

Dimensions

MHS3-100D, 125D

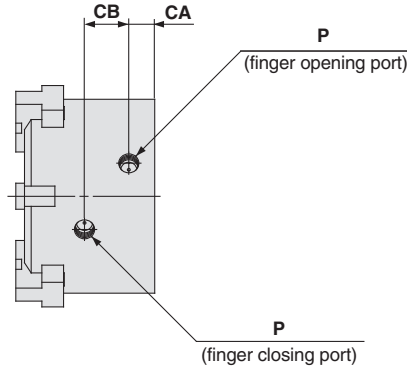
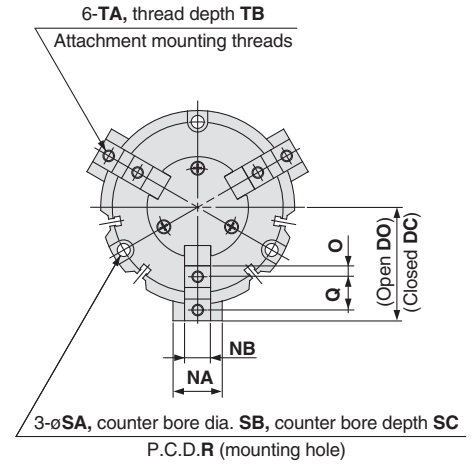
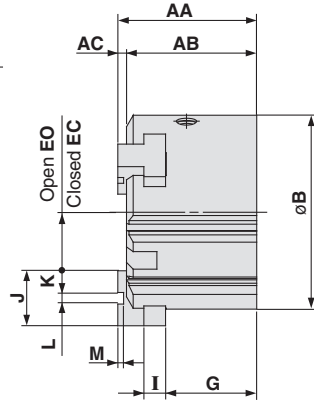
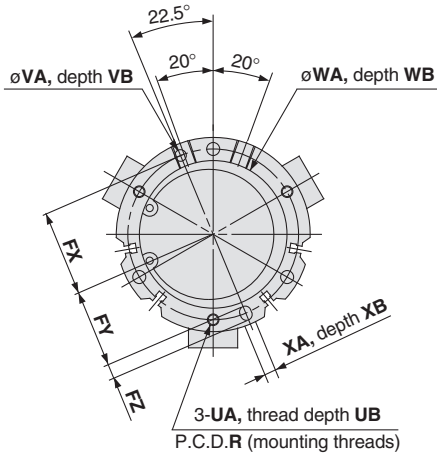

Auto switch mounting groove positions (4 locations)

MHS3-100D

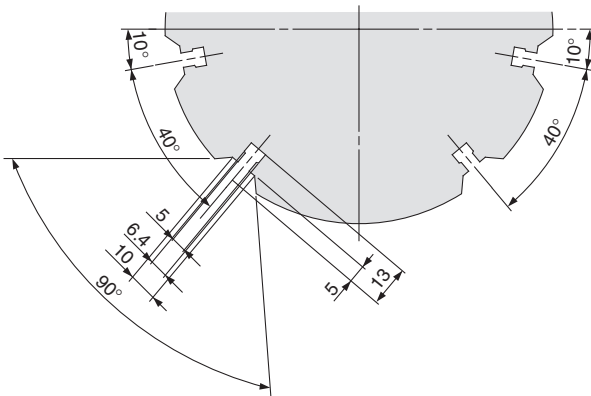

MHS3-125D

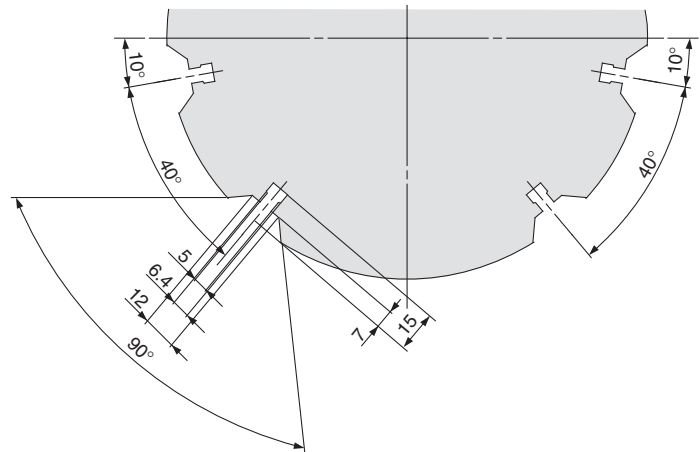

Model	AA	AB	AC	B	CA	CB	DC	DO	EC	EO	FX	FY	FZ	G	I	J	K	L	M	NA	NB
MHS3-100D	96	90	6	134	18	30.6	66	78	28	40	59	54	10	63	15	38	15	8H9 ^{+0.036} ₀	4	34	18h9 ⁰ _{-0.043}
MHS3-125D	122	114	8	166	23.5	38	82	98	30	46	74	68	12	84	18	52	21	10H9 ^{+0.036} ₀	6	40	22h9 ⁰ _{-0.052}
Model	O	P	Q	R	SA	SB	SC	TA	TB	UA	UB	VA	VB	WA	WB	XA	XB				
MHS3-100D	7.5	1/4	23	118	9	14	21	M8	16	M8	16	8H9 ^{+0.036} ₀	6	102H9 ^{+0.087} ₀	4	8H9 ^{+0.036} ₀	6				
MHS3-125D	10.5	3/8	31	148	11	17.5	34	M10	20	M10	20	10H9 ^{+0.036} ₀	8	130H9 ^{+0.100} ₀	6	10H9 ^{+0.036} ₀	8				

3 Finger Air Gripper Parallel Type

With Dust Cover
 $\varnothing 16, \varnothing 20, \varnothing 25, \varnothing 32, \varnothing 40, \varnothing 50, \varnothing 63, \varnothing 80$

How to Order

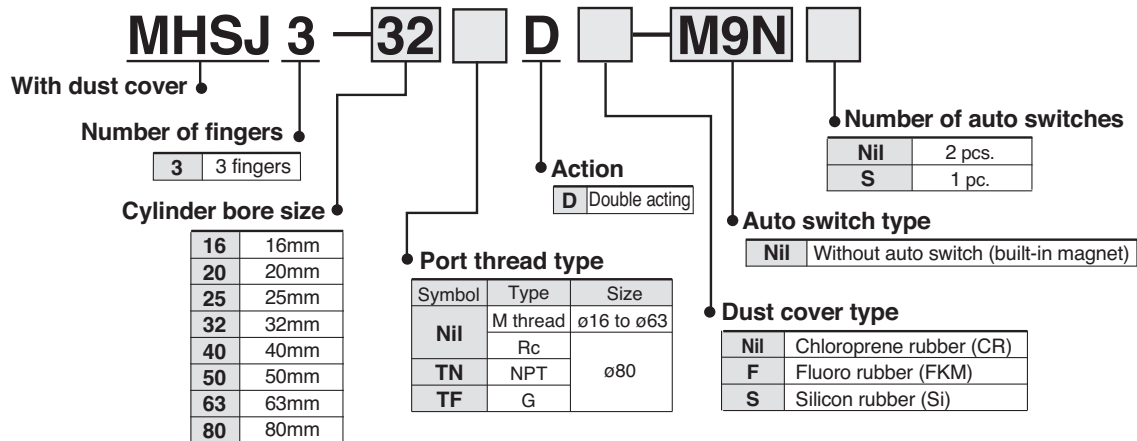

Applicable Auto Switches

Type	Special function	Electrical entry	Indicator light	Wiring (Output)	Load voltage		Auto switch model		Lead wire length (m)*				Pre-wired connector	Applicable load
					DC	AC	Electrical entry direction		0.5 (Nil)	1 (M)	3 (L)	5 (Z)		
							Perpendicular	In-line						
Solid state auto switch	—	Grommet	Yes	3-wire(NPN)	5 V, 12 V	—	M9NV	M9N	●	●	●	○	○	Relay, PLC
				3-wire(PNP)			M9PV	M9P	●	●	●	○	○	
				2-wire	M9BV	M9B	●	●	●	○	○			
				3-wire(NPN)	5 V, 12 V	—	M9NVW	M9NW	●	●	●	○	○	
				3-wire(PNP)			M9PVW	M9PW	●	●	●	○	○	
				2-wire	M9BWW	M9BW	●	●	●	○	○			
	Water resistant (2-colour indication)	Grommet	Yes	3-wire(NPN)	5 V, 12 V	—	M9NAV**	M9NA**	○	○	●	○	○	Relay, PLC
				3-wire(PNP)			M9PAV**	M9PA**	○	○	●	○	○	
				2-wire	M9BAV**	M9BA**	○	○	●	○	○			

** Water resistant type auto switches can be mounted on the above models, but in such case SMC cannot guarantee water resistance.
 * Lead wire length symbols: 0.5 m Nil (Example) M9NW
 1 m M (Example) M9NWM
 3 m L (Example) M9NWL
 5 m Z (Example) M9NWZ
 * Auto switches marked with a "○" symbol are produced upon receipt of order.

Note 1) When using the 2-colour indicator type, please make the setting so that the indicator is lit in red to ensure the detection at the proper position of the air gripper.

Models and Specifications



Model	MHSJ3-16D	MHSJ3-20D	MHSJ3-25D	MHSJ3-32D	MHSJ3-40D	MHSJ3-50D	MHSJ3-63D	MHSJ3-80D
Cylinder bore size mm	16	20	25	32	40	50	63	80
Fluid	Air							
Operating pressure MPa	0.2 to 0.6			0.1 to 0.6				
Ambient and fluid temperature C	-10 to 60							
Repeatability mm	0.01							
Max. operating frequency c.p.m.	120			60				30
Lubrication	Non-lube							
Action	Double acting							
Effective gripping force N at pressure of 0.5MPa	9	21	36	62	97	155	280	400
Opening/closing stroke mm (dia.)	4	4	6	8	8	12	16	20
Weight g	95	150	230	440	620	1,050	1,800	3,200

Note 1) Values for $\varnothing 16$ to $\varnothing 25$ are with gripping point L = 20mm, for $\varnothing 32$ to $\varnothing 63$ with gripping point L = 30mm, and for $\varnothing 80$ to $\varnothing 125$ with gripping point L = 50mm.
 Refer to the "Effective Gripping Force" data on pages 5-177 through 5-179 for the gripping force at each gripping position.

Note 2) Open and closed diameter values apply for external gripping of work pieces.

Series MHSJ3

Construction

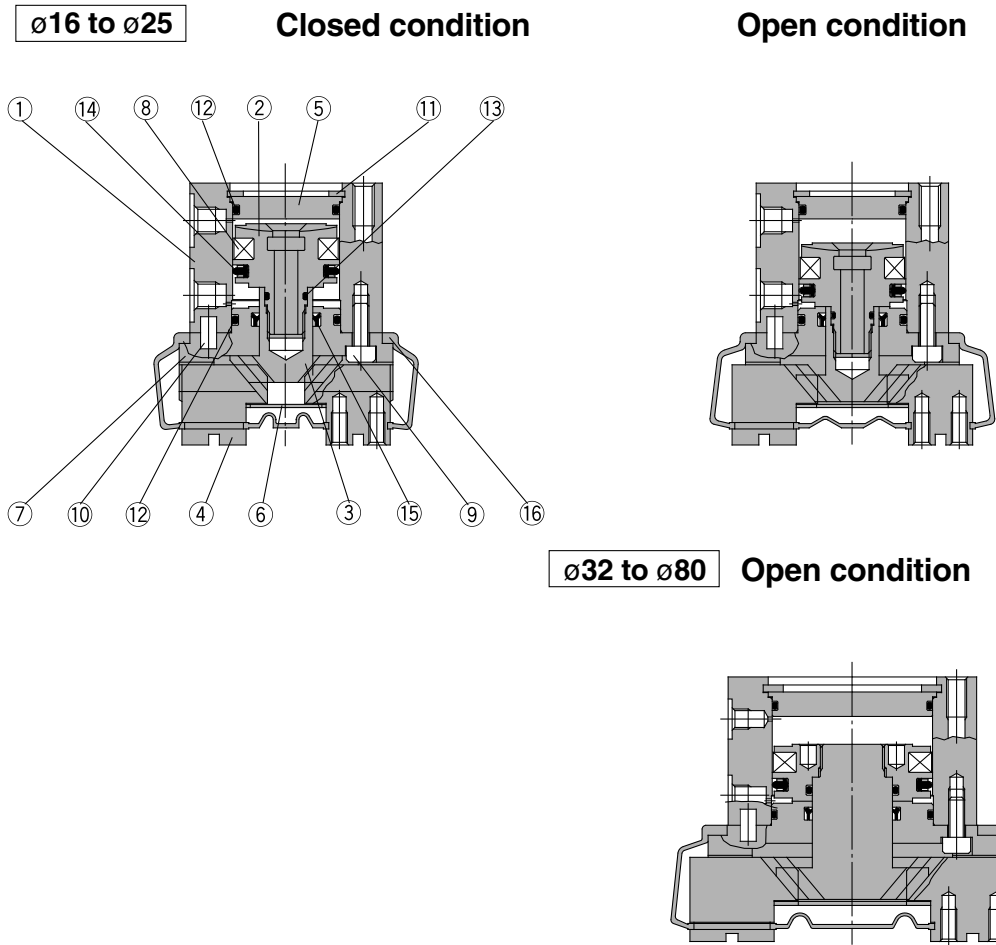

Parts list

No.	Description	Material	Note
1	Body	Aluminum alloy	Hard anodized
2	Piston	ø16 to ø25: Stainless steel	
		ø32 to ø80: Aluminum alloy	Hard anodized
3	Cam (J)	Carbon steel	Heat treated, Specially treated
4	Finger	Carbon steel	Heat treated, Specially treated
5	Cap (J)	Aluminum alloy	Hard anodized
6	End plate (J)	Stainless steel	
7	Guide	Aluminum alloy	Hard anodized

No.	Description	Material	Note
8	Rubber magnet	Synthetic rubber	
9	Hexagon socket head screw	Carbon steel	Nickel plated
10	Parallel pin	Stainless steel	
11	C type snap ring	Carbon steel	Nickel plated
12	Gasket	NBR	
13	Gasket	NBR	
14	Piston seal	NBR	
15	Rod seal	NBR	

Replacement parts/Seal kits

Kit number								Contents
MHSJ3-16D□	MHSJ3-20D□	MHSJ3-25D□	MHSJ3-32D□	MHSJ3-40D□	MHSJ3-50D□	MHSJ3-63D□	MHSJ3-80D□	
MHSJ16-PS	MHSJ20-PS	MHSJ25-PS	MHSJ32-PS	MHSJ40-PS	MHSJ50-PS	MHSJ63-PS	MHSJ80-PS	A set of the above Nos. 12, 13, 14 & 15

□ Seal kits are sets consisting of items 12, 13, 14 and 15, which can be ordered using the kit number for each cylinder bore size.

Replacement parts/Dust cover (J)

No.	Description	Material	Part number							
			MHSJ3-16D□	MHSJ3-20D□	MHSJ3-25D□	MHSJ3-32D□	MHSJ3-40D□	MHSJ3-50D□	MHSJ3-63D□	MHSJ3-80D□
16	Dust cover (J)	CR ^{Note)}	MHSJ3-J16	MHSJ3-J20	MHSJ3-J25	MHSJ3-J32	MHSJ3-J40	MHSJ3-J50	MHSJ3-J63	MHSJ3-J80
		FKM ^{Note)}	MHSJ3-J16F	MHSJ3-J20F	MHSJ3-J25F	MHSJ3-J32F	MHSJ3-J40F	MHSJ3-J50F	MHSJ3-J63F	MHSJ3-J80F
		Si ^{Note)}	MHSJ3-J16S	MHSJ3-J20S	MHSJ3-J25S	MHSJ3-J32S	MHSJ3-J40S	MHSJ3-J50S	MHSJ3-J63S	MHSJ3-J80S

Note) CR: Chloroprene rubber, FKM: Fluoro rubber, Si: Silicon rubber

Gripping Point

- The work piece gripping point distance should be within the gripping force ranges given for each pressure in the effective gripping force graphs below.
- If operated with the work piece gripping point beyond the indicated ranges, an excessive offset load will be applied to the sliding section of the fingers, which can have an adverse effect on the service life of the product.

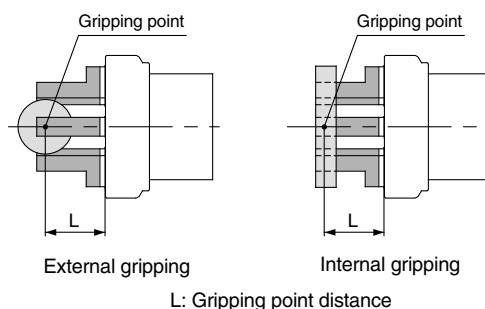

Effective Gripping Force

- Expressing the effective gripping force
The effective gripping force shown in the graphs to the right is expressed as F, which is the impellent force of one finger when all 3 of the fingers and attachments are in full contact with the work piece as shown in the figure below.

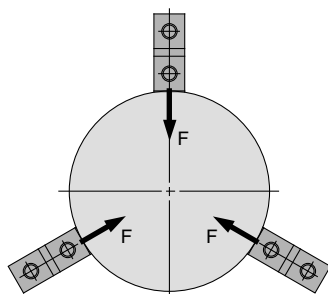

External gripping

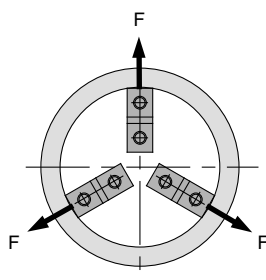

Internal gripping

1N: Approx. 0.102kgf
1MPa: Approx. 10.2kgf/cm²

External gripping force

MHSJ3-16D

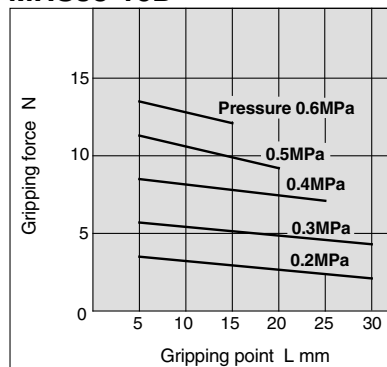

MHSJ3-20D

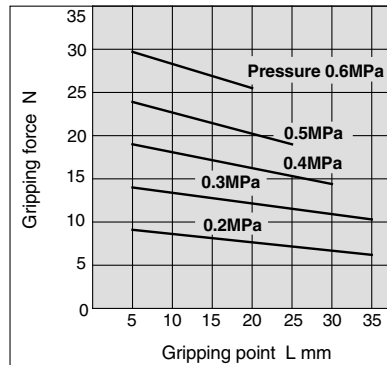

MHSJ3-25D

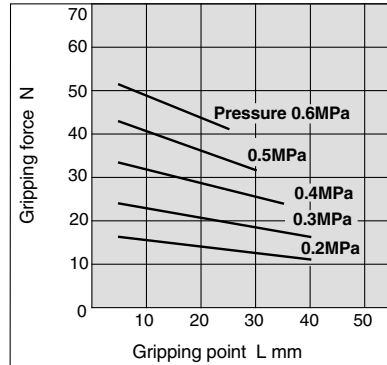

Internal gripping force

MHSJ3-16D

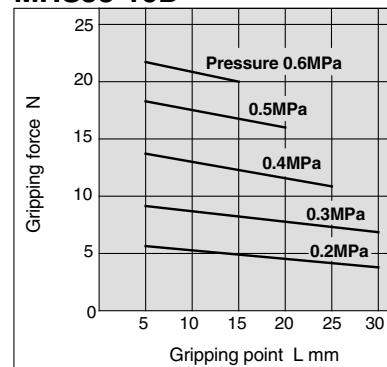

MHSJ3-20D

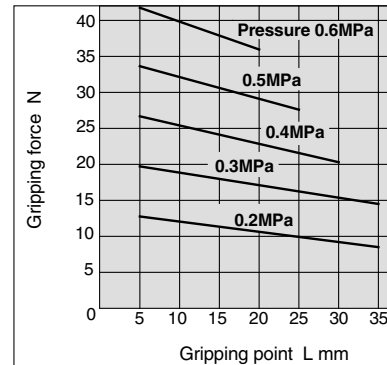

MHSJ3-25D

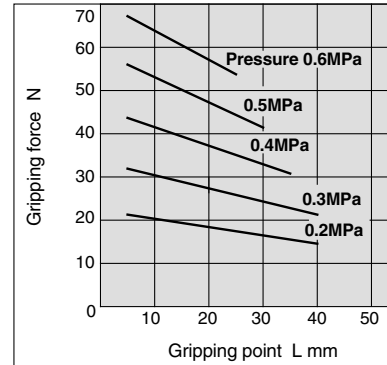

Series MHSJ3

Effective Gripping Force

- Expressing the effective gripping force
The effective gripping force shown in the graphs to the right is expressed as F, which is the impellent force of one finger when all 3 of the fingers and attachments are in full contact with the work piece as shown in the figure below.

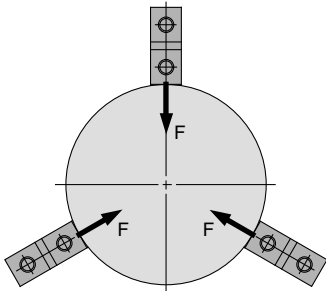

External gripping

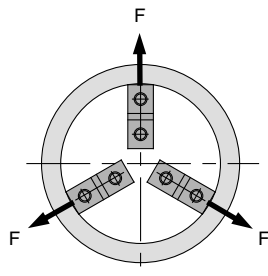

Internal gripping

1N: Approx. 0.102kgf
1MPa: Approx. 10.2kgf/cm²

External gripping force

MHSJ3-32D

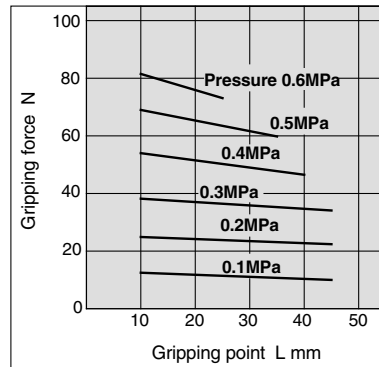

MHSJ3-40D

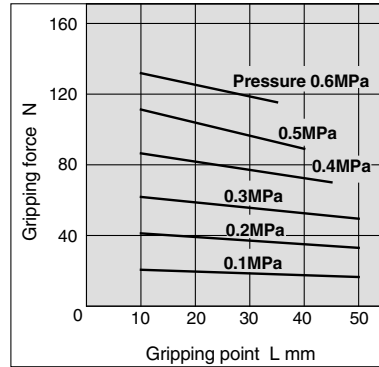

MHSJ3-50D

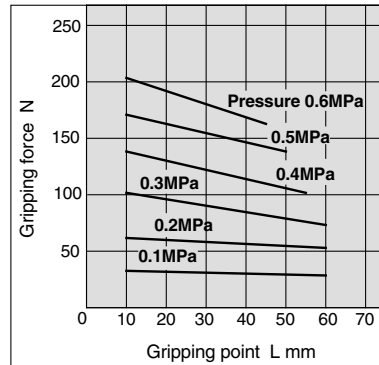

MHSJ3-63D

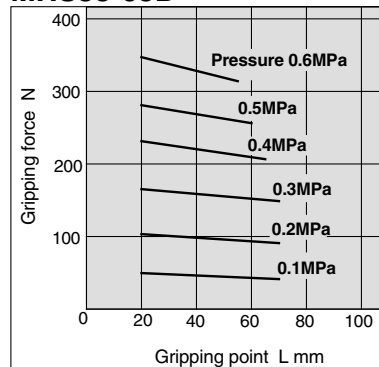

Internal gripping force

MHSJ3-32D

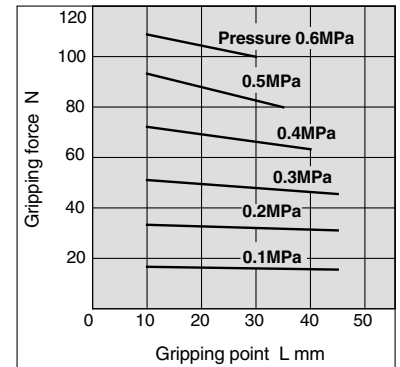

MHSJ3-40D

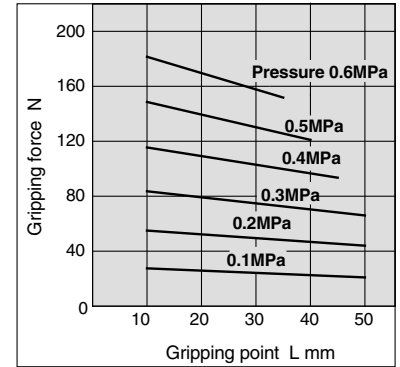

MHSJ3-50D

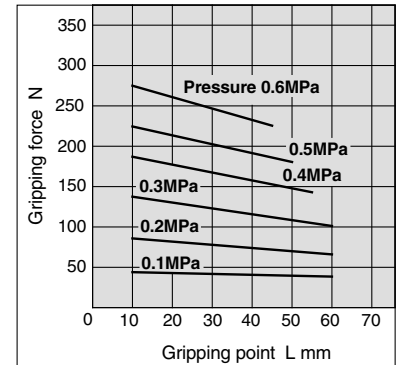

MHSJ3-63D

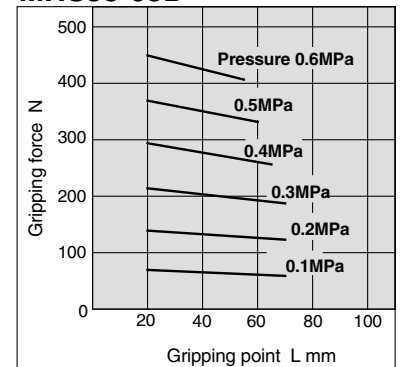

External gripping force

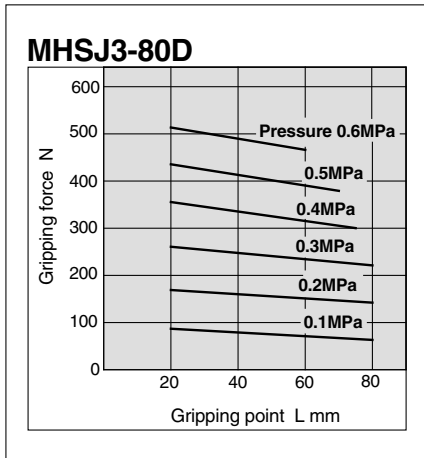

Internal gripping force

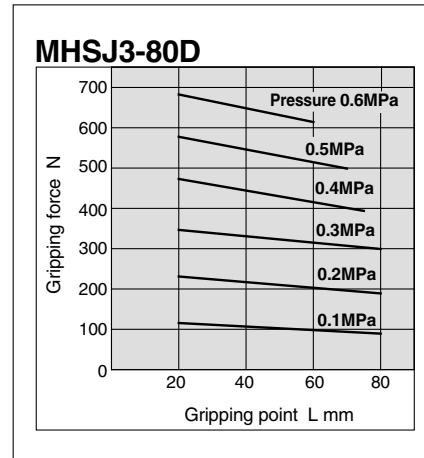

Series MHSJ3

Dimensions

MHSJ3-16D to 25D

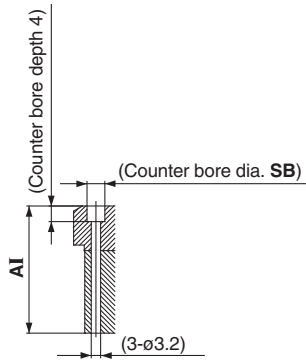
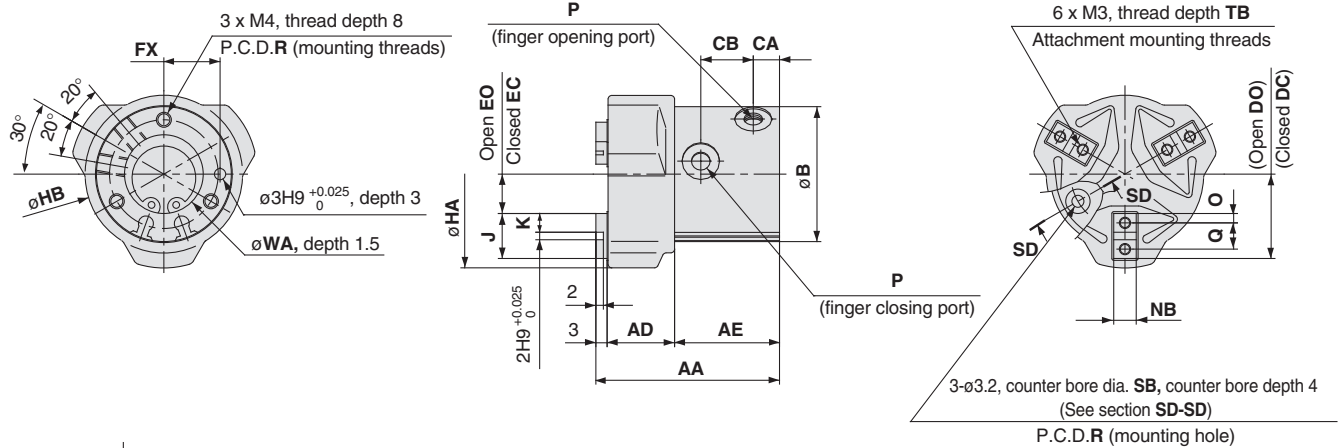

Section SD - SD

Auto switch mounting groove positions (2 locations)

MHSJ3-16D

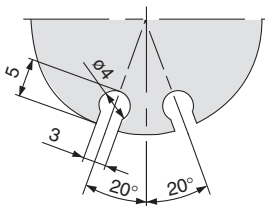

MHSJ3-20D

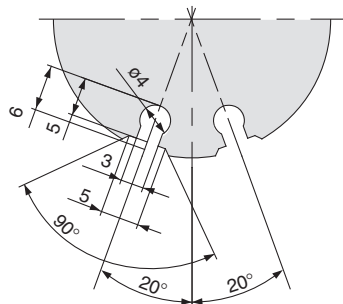

MHSJ3-25D

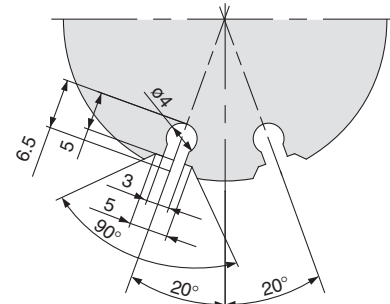

Model	AA	AD	AE	AI	B	CA	CB	DC	DO	EC	EO	FX	HA	HB	J	K	NB	O	P	Q
MHSJ3-16D	46	16	27	39	30	7	14	17.5	19.5	7.5	9.5	12	44	36	10	4	5h9 $^{0}_{-0.030}$	2	M3	6
MHSJ3-20D	49	18	28	42	36	7	14	20	22	8	10	15	50	42	12	5	6h9 $^{0}_{-0.030}$	2.5	M5	7
MHSJ3-25D	55	20	32	47	42	7.5	17.5	23.5	26.5	9.5	12.5	18	59	50	14	6	6h9 $^{0}_{-0.030}$	3	M5	8

Model	R	SB	TB	WA
MHSJ3-16D	24	6	5	17H9 $^{+0.043}_0$
MHSJ3-20D	29	6.5	6	21H9 $^{+0.052}_0$
MHSJ3-25D	34	6.5	6	26H9 $^{+0.052}_0$

MHSJ3-32D to 80D

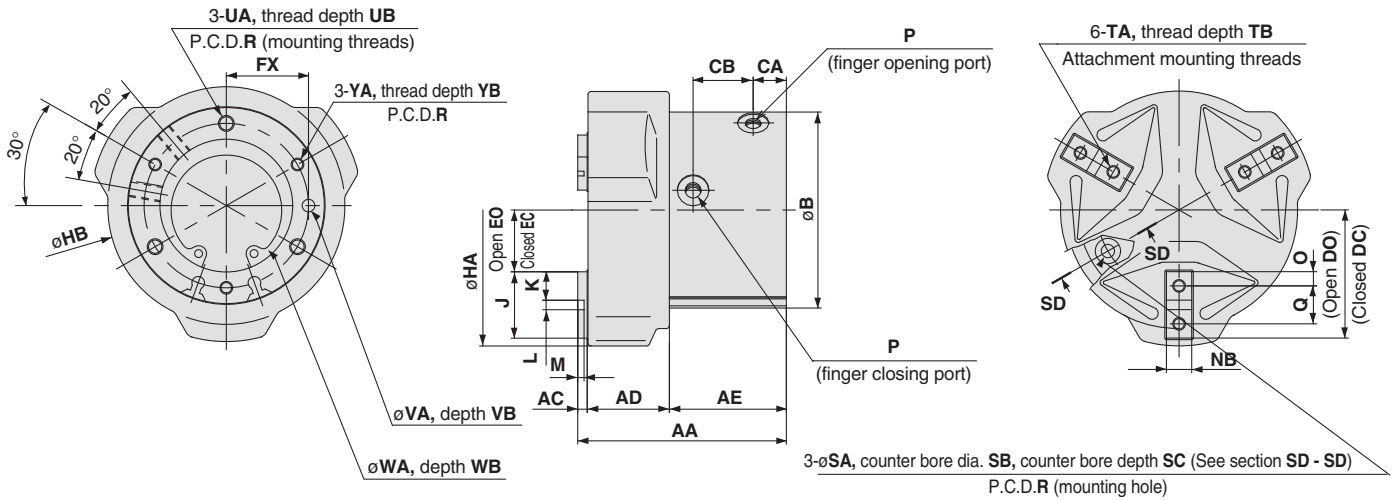

Auto switch mounting groove positions (2 locations)

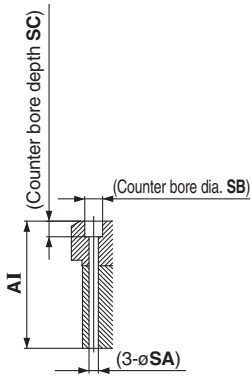

MHSJ3-32D

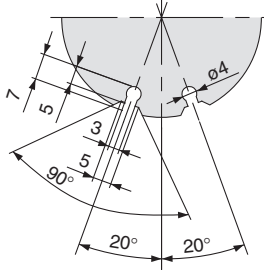

MHSJ3-40D

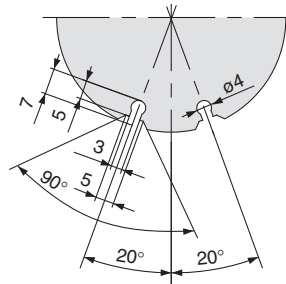

MHSJ3-50D

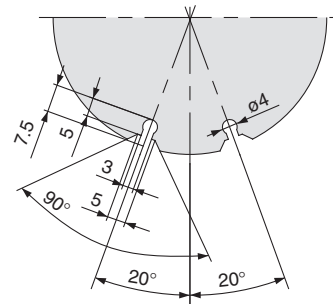

Section SD - SD

MHSJ3-63D

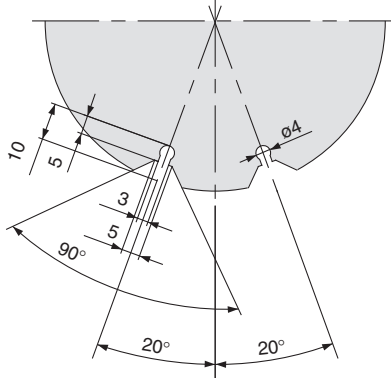

MHSJ3-80D

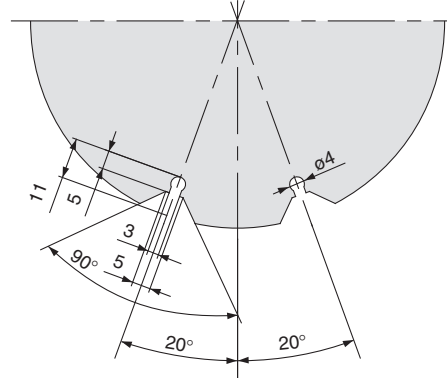

(mm)

Model	AA	AC	AD	AE	AI	B	CA	CB	DC	DO	EC	EO	FX	HA	HB	J	K	L	M	NB
MHSJ3-32D	63	3	24	36	54	54	9.5	19	31.5	35.5	11.5	15.5	22	76	65	20	9	2H9 ^{+0.025} ₀	2	8h9 ⁰ _{-0.036}
MHSJ3-40D	66	3	26	37	57	62	10.5	19	36	40	15	19	26	86	75	21	9	3H9 ^{+0.025} ₀	2	8h9 ⁰ _{-0.036}
MHSJ3-50D	80	3	31	46	70	74	11.5	26.5	42	48	18	24	32	103	88	24	10	4H9 ^{+0.030} ₀	2	10h9 ⁰ _{-0.036}
MHSJ3-63D	91	4	37	50	79	92	13	28	51	59	23	31	40	125	106	28	11	6H9 ^{+0.030} ₀	3	12h9 ⁰ _{-0.043}
MHSJ3-80D	108	5	46	57	93	112	14	31	63	73	31	41	50	158	130	32	12	8H9 ^{+0.036} ₀	4	14h9 ⁰ _{-0.043}

Model	O	P	Q	R	SA	SB	SC	TA	TB	UA	UB	VA	VB	WA	WB	YA	YB
MHSJ3-32D	4.5	M5	11	44	4.2	8	7	M4	8	M5 x 0.8	10	4H9 ^{+0.030} ₀	4	34H9 ^{+0.062} ₀	2	M4 x 0.7	8
MHSJ3-40D	4.5	M5	12	52	4.2	8	7	M4	8	M5 x 0.8	10	4H9 ^{+0.030} ₀	4	42H9 ^{+0.062} ₀	2	M4 x 0.7	8
MHSJ3-50D	5	M5	14	63	5.1	9.5	8	M5	10	M6 x 1	12	5H9 ^{+0.030} ₀	5	52H9 ^{+0.074} ₀	2	M5 x 0.8	10
MHSJ3-63D	5.5	M5	17	78	6.6	11	8	M5	10	M8 x 1.25	16	6H9 ^{+0.030} ₀	6	65H9 ^{+0.074} ₀	2.5	M6 x 1	12
MHSJ3-80D	6	Rc 1/8	20	98	6.6	11	8	M6	12	M8 x 1.25	16	6H9 ^{+0.030} ₀	6	82H9 ^{+0.087} ₀	3	M6 x 1	12

3 Finger Air Gripper Parallel Type

Through Hole

Series MSHH3

ø16, ø20, ø25, ø32, ø40, ø50, ø63, ø80

How to Order

MHSH **3** - **32** **D** **M9N**

Through hole

Dust cover

Nil	Without dust cover
J	With dust cover

Note) ø16, ø20 and ø25 are not available with dust cover.

Number of fingers

3	3 fingers
---	-----------

Cylinder bore size

16	16mm
20	20mm
25	25mm
32	32mm
40	40mm
50	50mm
63	63mm
80	80mm

Port thread type

Symbol	Type	Size
Nil	M thread	ø16 to ø63
	Rc	
TN	NPT	ø80
TF	G	

Action

D	Double acting
---	---------------

Number of auto switches

Nil	2 pcs.
S	1 pc.
n (Note 2)	"n" pcs.

Note) Symbol entry examples when mounting auto switches on air gripper with cylinder type centre pusher

- Air gripper unit 1 pc. } Total of 2 pcs. Æ Nil
centre pusher unit 1 pc. }
MHSH3-32DA-M9N
- Air gripper unit 2 pcs. } Total of 4 pcs. Æ Enter "4"
centre pusher unit ... 2 pcs. }
MHSH3-32DA-M9N4

Auto switch type

Nil	Without auto switch (built-in magnet)
-----	---------------------------------------

Dust cover type (with dust cover only)

Nil	Chloroprene rubber (CR)
F	Fluoro rubber (FKM)
S	Silicon rubber (Si)

centre pusher

Nil	Without centre pusher
A	Cylinder type
B	Spring type

Note) ø16, ø20 and ø25 are not available with centre pusher.

centre Pusher Assembly

MHSH 3 - **A** **50** **A** - **M9N**

Through hole

Number of fingers

3	3 fingers
---	-----------

centre pusher assembly

Air gripper cylinder bore size

32	32mm
40	40mm
50	50mm
63	63mm
80	80mm

Number of auto switches

Nil	2 pcs.
S	1 pc.

Auto switch type (cylinder type only)

Nil	Without auto switch (built-in magnet)
-----	---------------------------------------

centre pusher

A	Cylinder type
B	Spring type

Applicable Auto Switches

Type	Special function	Electrical entry	Indicator light	Wiring (Output)	Load voltage		Auto switch model		Lead wire length (m)*				Pre-wired connector	Applicable load		
					DC	AC	Electrical entry direction		0.5 (Nil)	1 (M)	3 (L)	5 (Z)				
							Perpendicular	In-line								
Solid state auto switch	—	Grommet	Yes	3-wire(NPN)	5 V, 12 V	—	M9NV	M9N	●	●	●	○	○	IC circuit		
				3-wire(PNP)			M9PV	M9P	●	●	●	○				
				2-wire	12 V	—	M9BV	M9B	●	●	●	○	○		—	
				3-wire(NPN)			M9NVV	M9NW	●	●	●	○	○			
				3-wire(PNP)	5 V, 12 V	—	M9PVV	M9PW	●	●	●	○	○		IC circuit	
				2-wire			M9BVV	M9BW	●	●	●	○	○			
	Water resistant (2-colour indication)	Grommet	Yes	Yes	3-wire(NPN)	5 V, 12 V	—	M9NAV**	M9NA**	○	○	●	○	○	IC circuit	
					3-wire(PNP)			M9PAV**	M9PA**	○	○	●	○	○		
					2-wire	12 V	—	M9BAV**	M9BA**	○	○	●	○	○		—

** Water resistant type auto switches can be mounted on the above models, but in such case SMC cannot guarantee water resistance.

* Lead wire length symbols: 0.5 m Nil (Example) M9NW
1 m M (Example) M9NWM
3 m L (Example) M9NWL
5 m Z (Example) M9NWZ

* Auto switches marked with a "O" symbol are produced upon receipt of order.

Note 1) When using the 2-colour indicator type, please make the setting so that the indicator is lit in red to ensure the detection at the proper position of the air gripper.

Models and Specifications

Without centre pusher



Centre pusher/cylinder type



Centre pusher/spring type



Air gripper specifications

Model	MHSH3-16D	MHSH3-20D	MHSH3-25D	MHSH3-32D	MHSH3-40D	MHSH3-50D	MHSH3-63D	MHSH3-80D	
Cylinder bore size mm	16	20	25	32	40	50	63	80	
Fluid	Air								
Operating pressure MPa	0.2 to 0.6				0.1 to 0.6				
Ambient and fluid temperature °C	-10 to 60								
Repeatability mm	±0.01								
Maximum operating frequency c.p.m.	120				60			30	
Lubrication	Non-lube								
Action	Double acting								
Effective gripping force N at pressure of 0.5MPa	External gripping force	9	21	36	62	97	155	280	400
	Internal gripping force	15	26	45	77	118	187	329	490
Through hole diameter mm	∅3H10 ^{+0.040} ₀	∅3H10 ^{+0.040} ₀	∅4H10 ^{+0.048} ₀	∅6H10 ^{+0.048} ₀	∅10H10 ^{+0.058} ₀	∅12H10 ^{+0.070} ₀	∅16H10 ^{+0.070} ₀	∅20H10 ^{+0.084} ₀	
Opening/closing stroke (dia.) mm	4	4	6	8	8	12	16	20	
Weight g	90	140	220	410	570	970	1,650	2,920	

Note 1) Values for ∅16 to ∅25 are with gripping point L = 20mm, for ∅32 to ∅63 with gripping point L = 30mm, and for ∅80 with gripping point L = 50mm. Refer to the "Effective Gripping Force" data on pages 5-186 through 5-189 for the gripping force at each gripping position.

Centre pusher (cylinder type) specifications

Model	MHSH3-32DA	MHSH3-40DA	MHSH3-50DA	MHSH3-63DA	MHSH3-80DA
Pusher cylinder bore size mm	12	20	25	32	40
Fluid	Air				
Operating pressure MPa	0.2 to 0.6		0.1 to 0.6		
Ambient and fluid temperature °C	-10 to 60				
Pusher maximum operating frequency c.p.m.	60				30
Lubrication	Non-lube				
Action	Double acting				
Pusher stroke mm	5	5	10	10	15
Pusher thrust N at pressure of 0.5MPa	Extension				
	45	130	204	335	524
Weight g	530	770	1,330	2,300	4,000

Centre pusher (spring type) specifications

Model	MHSH3-32DB	MHSH3-40DB	MHSH3-50DB	MHSH3-63DB	MHSH3-80DB
Pusher stroke mm	5	5	10	10	15
Pusher spring force N	6 to 10	11 to 15	20 to 25	29 to 34	49 to 59
Weight g	500	740	1,290	2,250	4,000

Weights

	∅32	∅40	∅50	∅63	∅80
Through hole with dust cover MHSHJ3-□D	430	600	1,020	1,710	3,040
centre pusher (cylinder type) with dust cover MHSHJ3-□DA	550	800	1,380	2,360	4,120
centre pusher (spring type) with dust cover MHSHJ3-□DB	520	770	1,340	2,310	4,120

Series MSHH3

Construction

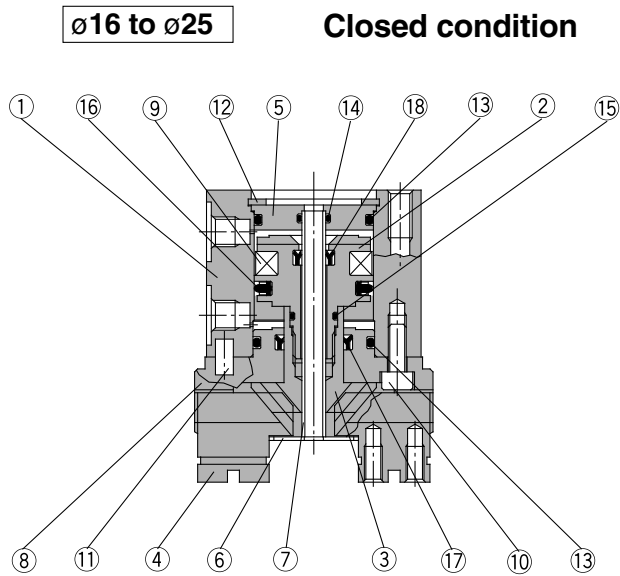

Open condition

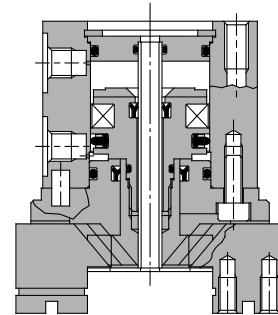

∅32 to ∅80

Open condition

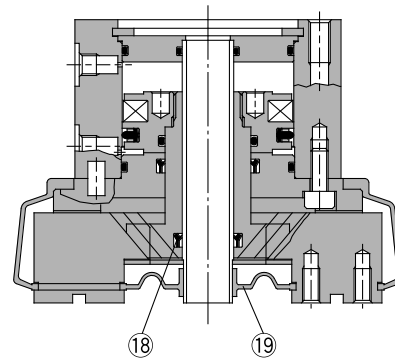

Parts list

No.	Description	Material	Note
1	Body	Aluminum alloy	Hard anodized
2	Piston	∅16 to ∅25: Stainless steel ∅32 to ∅80: Aluminum alloy	Hard anodized
3	Cam (A)	Carbon steel	Heat treated, Specially treated
4	Finger	Carbon steel	Heat treated, Specially treated
5	Cap (A)	Aluminum alloy	Hard anodized
6	End plate (A)	Stainless steel	
7	Tube	Stainless steel	
8	Guide	Aluminum alloy	Hard anodized
9	Rubber magnet	Synthetic rubber	
10	Hexagon socket head screw	Carbon steel	Nickel plated
11	Parallel pin	Stainless steel	
12	C type snap ring	Carbon steel	Nickel plated

No.	Description	Material	Note
13	Gasket	NBR	
14	Gasket	NBR	
15	Gasket	NBR	
16	Piston seal	NBR	
17	Rod seal	NBR	
18	Rod seal	NBR	

Replacement parts/Seal kits

MSHH3-16D	MSHH3-20D	MSHH3-25D	Kit number					MSHH3-80D	Contents
			MSHH3-32D	MSHH3-40D	MSHH3-50D	MSHH3-63D	MSHH3-80D		
MHSH16-PS	MHSH20-PS	MHSH25-PS	MHSHJ3-32D	MHSHJ3-40D	MHSHJ3-50D	MHSHJ3-63D	MHSHJ3-80D	A set of the above Nos. 13, 14, 15, 16, 17 & 18	

□ Seal kits are sets consisting of items 13, 14, 15, 16, 17 and 18, which can be ordered using the kit number for each cylinder bore size.

Replacement parts/Dust cover (A)

No.	Description	Material	Part number				
			MSHH3-32D	MSHH3-40D	MSHH3-50D	MSHH3-63D	MSHH3-80D
19	Dust cover (A)	CR ^{Note)}	MHSHJ3-J32	MHSHJ3-J40	MHSHJ3-J50	MHSHJ3-J63	MHSHJ3-J80
		FKM ^{Note)}	MHSHJ3-J32F	MHSHJ3-J40F	MHSHJ3-J50F	MHSHJ3-J63F	MHSHJ3-J80F
		Si ^{Note)}	MHSHJ3-J32S	MHSHJ3-J40S	MHSHJ3-J50S	MHSHJ3-J63S	MHSHJ3-J80S

Note) CR: Chloroprene rubber, FKM: Fluoro rubber, Si: Silicon rubber

Construction

Centre pusher/cylinder type

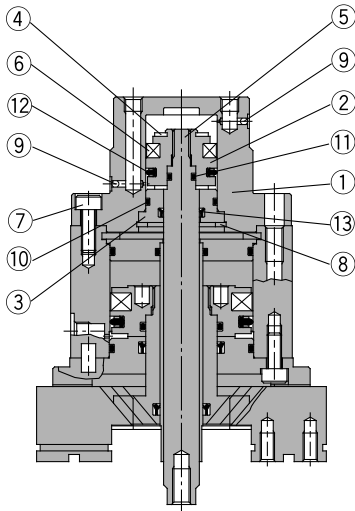

Parts list

No.	Description	Material	Note
1	Push holder (P)	Aluminum alloy	Hard anodized
2	Piston (P)	Aluminum alloy	Hard anodized
3	Rod holder	Aluminum alloy	Hard anodized
4	Bumper	Urethane rubber	
5	Push rod (P)	Stainless steel	Hard chromed
6	Rubber magnet	Synthetic rubber	
7	Hexagon socket head screw	Carbon steel	Nickel plated
8	C type snap ring	Carbon steel	Nickel plated
9	Steel ball	Stainless steel	
10	Gasket	NBR	
11	Gasket	NBR	
12	Piston seal	NBR	
13	Rod seal	NBR	

Replacement parts/Seal kits (centre pusher/cylinder type)

Kit number					Contents
MHSH3-A32A	MHSH3-A40A	MHSH3-A50A	MHSH3-A63A	MHSH3-A80A	
MHSH32A-PS	MHSH40A-PS	MHSH50A-PS	MHSH63A-PS	MHSH80A-PS	A set of the above Nos. 10, 11, 12 & 13

□ Seal kits are sets consisting of items 10, 11, 12 and 13, which can be ordered using the kit number for each cylinder bore size.

Construction

Centre pusher/spring type

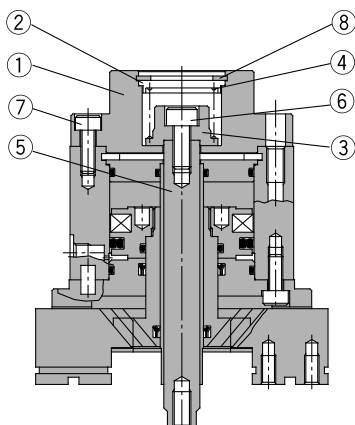

Parts list

No.	Description	Material	Note
1	Push holder (S)	Aluminum alloy	Hard anodized
2	Cap (S)	Stainless steel	
3	Spring holder	Stainless steel	
4	Spring	Stainless steel	
5	Push rod (S)	Stainless steel	Hard chromed
6	Hexagon socket head screw	Carbon steel	Nickel plated
7	Hexagon socket head screw	Carbon steel	Nickel plated
8	C type snap ring	Carbon steel	Nickel plated

Series MSH3

Gripping Point

- The work piece gripping point distance should be within the gripping force ranges given for each pressure in the effective gripping force graphs below.
- If operated with the work piece gripping point beyond the indicated ranges, an excessive offset load will be applied to the sliding section of the fingers, which can have an adverse effect on the service life of the product.

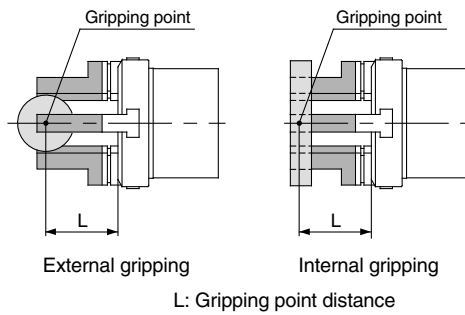

Effective Gripping Force

- Expressing the effective gripping force
The effective gripping force shown in the graphs to the right is expressed as F, which is the impellent force of one finger when all 3 of the fingers and attachments are in full contact with the work piece as shown in the figure below.

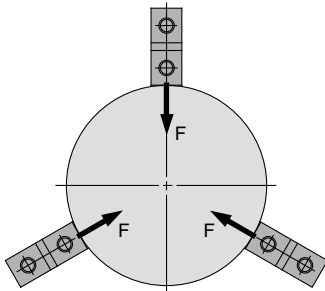

External gripping

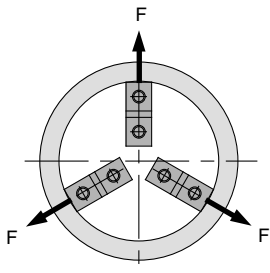

Internal gripping

1N: Approx. 0.102kgf
1MPa: Approx. 10.2kgf/cm²

External gripping force

MSH3-16D

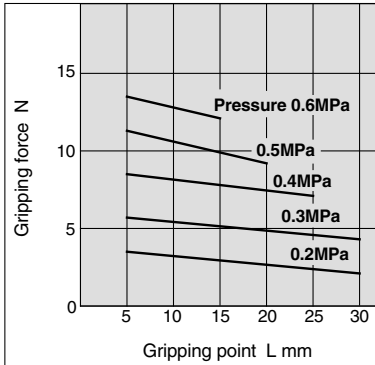

MSH3-20D

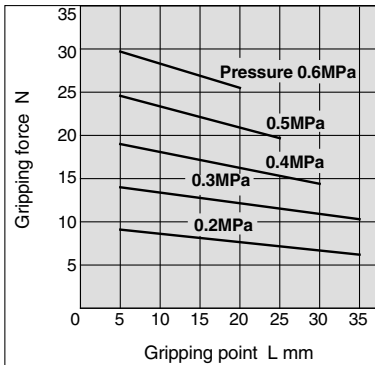

MSH3-25D

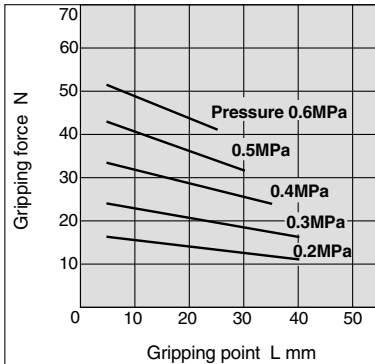

Internal gripping force

MSH3-16D

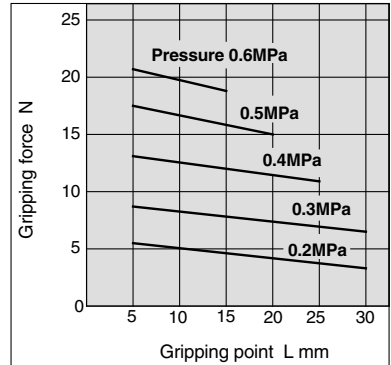

MSH3-20D

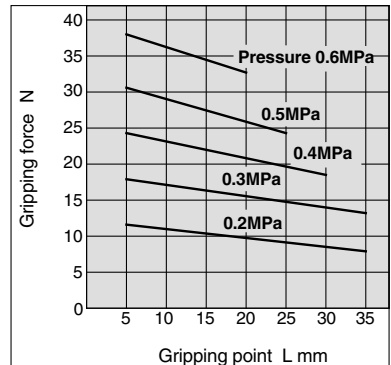

MSH3-25D

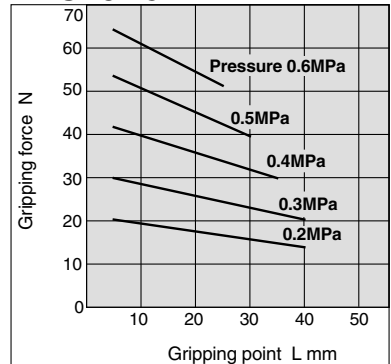

Effective Gripping Force

- Expressing the effective gripping force

The effective gripping force shown in the graphs to the right is expressed as F , which is the impellent force of one finger when all 3 of the fingers and attachments are in full contact with the work piece as shown in the figure below.

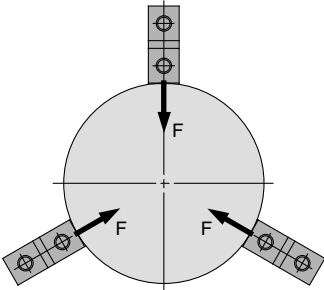

External gripping

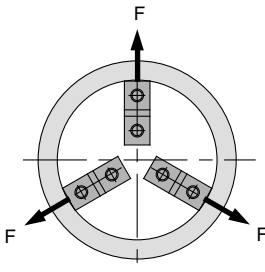

Internal gripping

1N: Approx. 0.102kgf
1MPa: Approx. 10.2kgf/cm²

External gripping force

MHSH3-32D

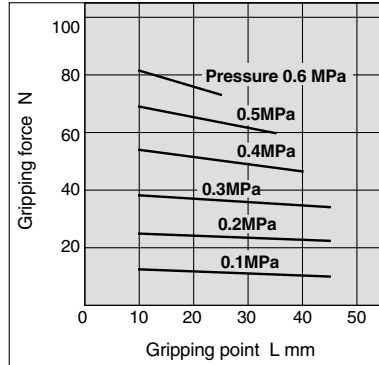

MHSH3-40D

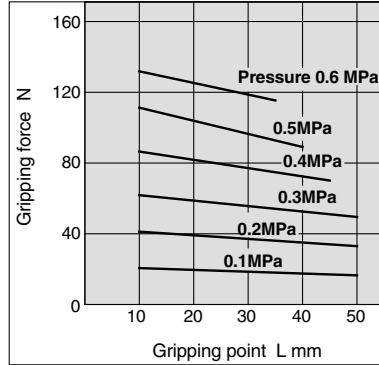

MHSH3-50D

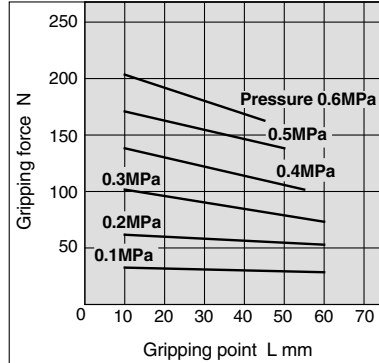

MHSH3-63D

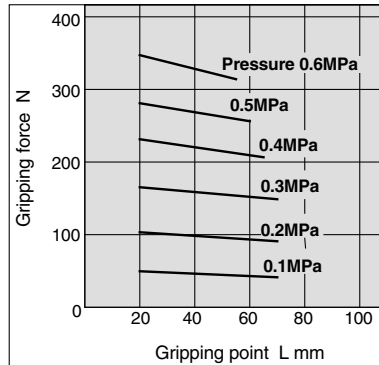

Internal gripping force

MHSH3-32D

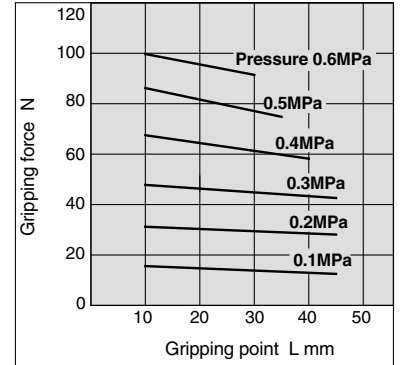

MHSH3-40D

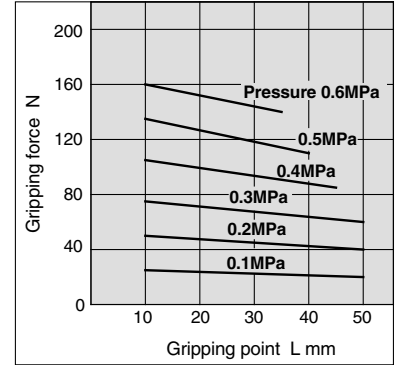

MHSH3-50D

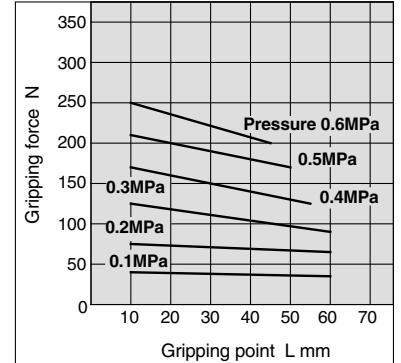

MHSH3-63D

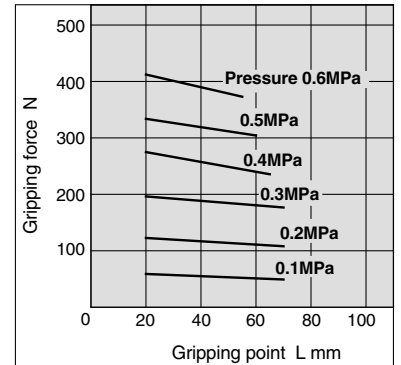

Series MSH3

Effective Gripping Force

- Expressing the effective gripping force
The effective gripping force shown in the graphs to the right is expressed as F, which is the impellent force of one finger when all 3 of the fingers and attachments are in full contact with the work piece as shown in the figure below.

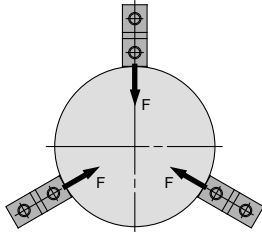

External gripping

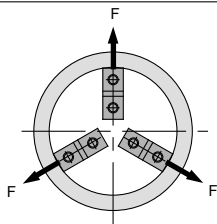

Internal gripping

1N: Approx. 0.102kgf
1MPa: Approx. 10.2kgf/cm²

External gripping force

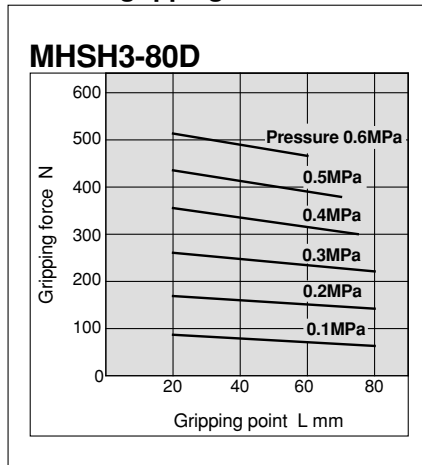

Internal gripping force

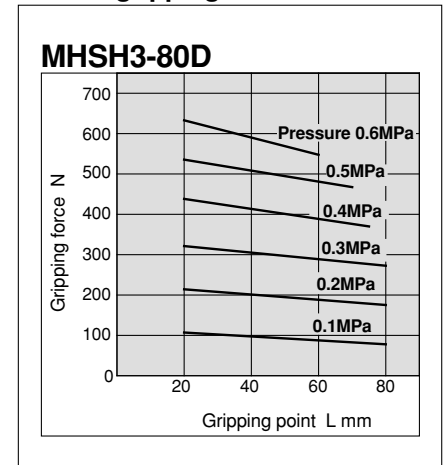

Effective Thrust of Centre Pusher

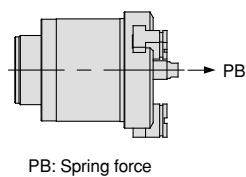
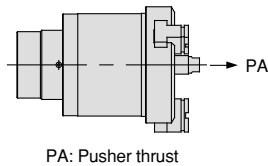

Cylinder type (Note1)

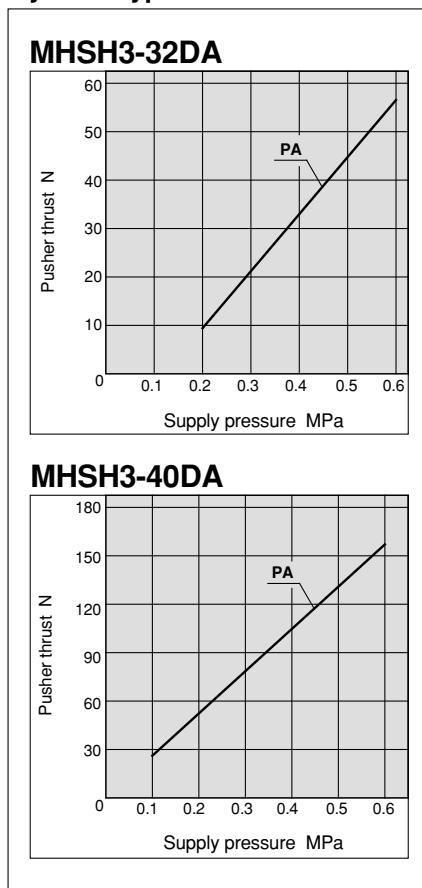

Spring type

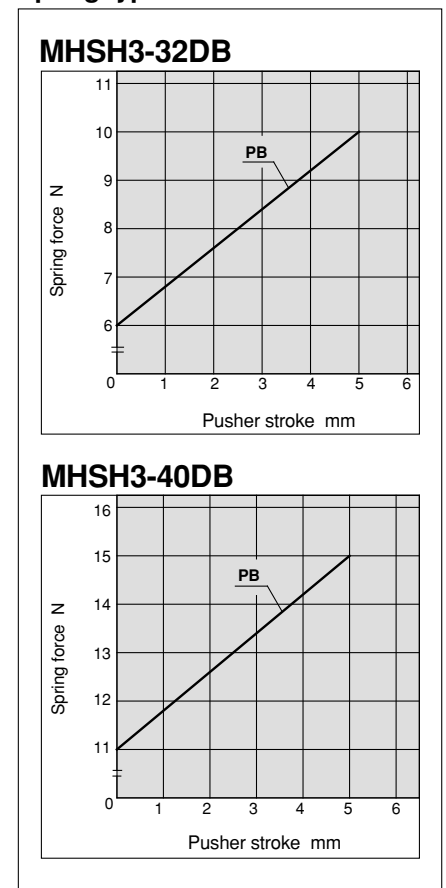

Note1) The thrust of the cylinder type is on extension of the push rod.

Effective Thrust of Centre Pusher

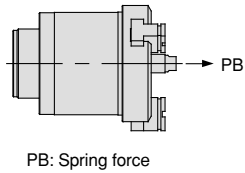
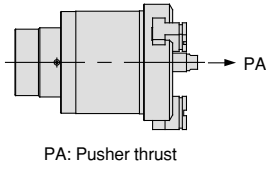

Cylinder type (Note1)

MSH3-50DA

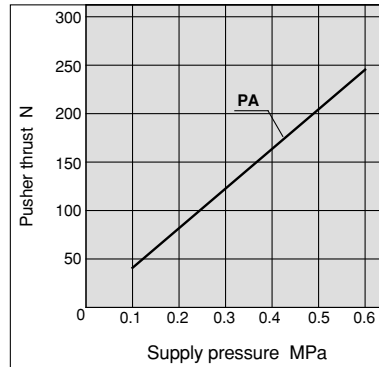

MSH3-63DA

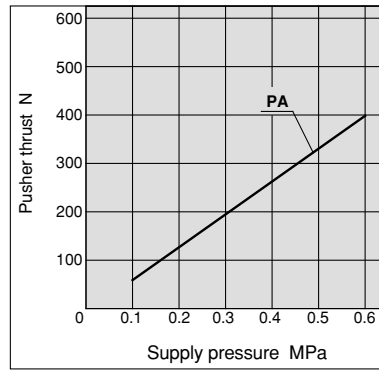

MSH3-80DA

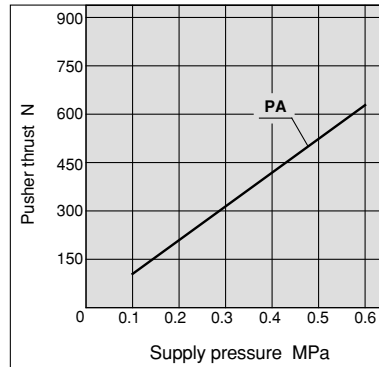

Spring type

MSH3-50DB

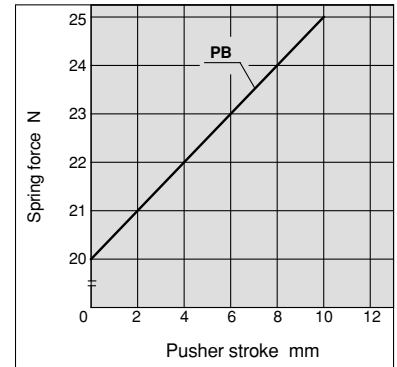

MSH3-63DB

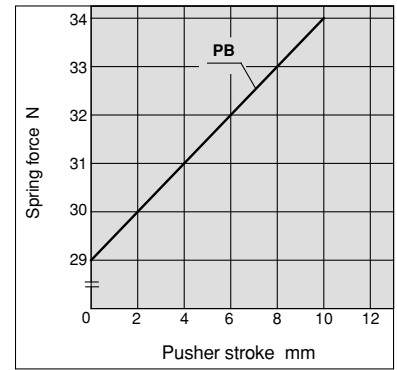

MSH3-80DB

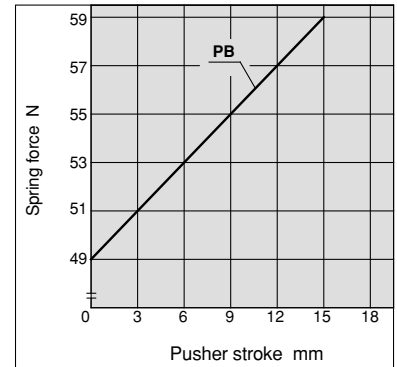

Note1) The thrust of the cylinder type is on extension of the push rod.

Series MSH3

Dimensions

MSH3-16D to 25D

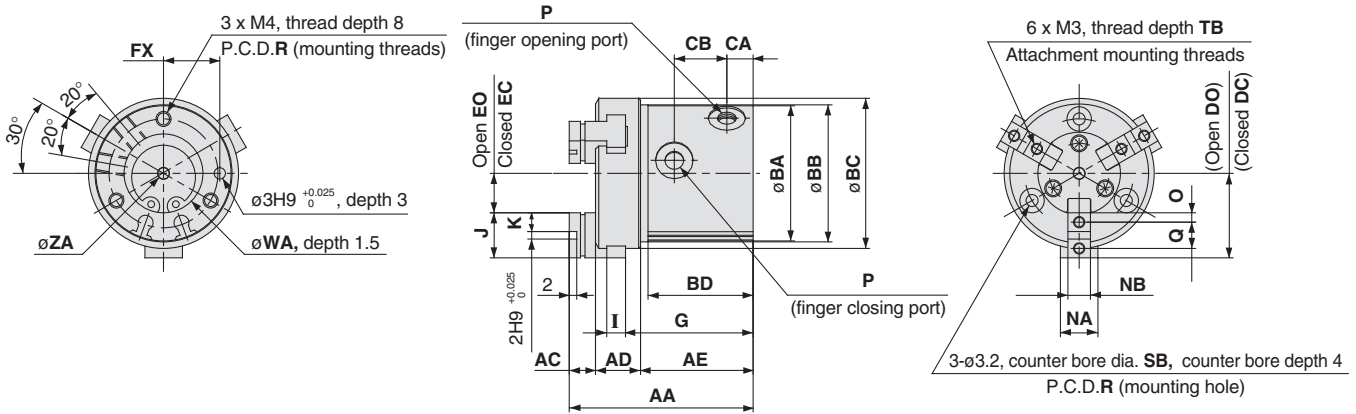

Auto switch mounting groove positions (2 locations)

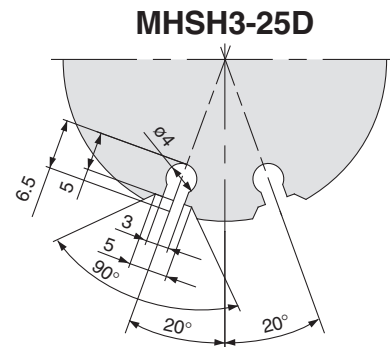
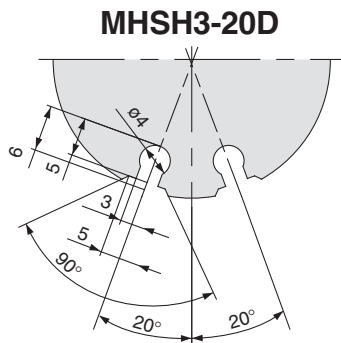
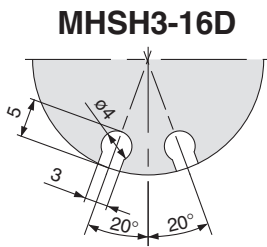

Model	AA	AC	AD	AE	BA	BB	BC	BD	CA	CB	DC	DO	EC	EO	FX	G	I	J	K	NA	NB
MSH3-16D	46	7	10.5	28.5	30	30.5	34	27	7	14	17.5	19.5	7.5	9.5	12	32	4	10	4	8	5h9 ₀ ⁰ -0.030
MSH3-20D	49	7	12	30	36	36.5	40	28	7	14	20	22	8	10	15	34	5	12	5	10	6h9 ₀ ⁰ -0.030
MSH3-25D	55	8	13	34	42	42.5	47	32	7.5	17.5	23.5	26.5	9.5	12.5	18	38	5	14	6	12	6h9 ₀ ⁰ -0.030

Model	O	P	Q	R	SB	TB	WA	ZA
MSH3-16D	2	M3	6	24	6	5	17H9 ₀ ^{+0.043}	3H10 ₀ ^{+0.040}
MSH3-20D	2.5	M5	7	29	6.5	6	21H9 ₀ ^{+0.052}	3H10 ₀ ^{+0.040}
MSH3-25D	3	M5	8	34	6.5	6	26H9 ₀ ^{+0.052}	4H10 ₀ ^{+0.048}

Series MSHH3

Dimensions: Centre Pusher/Cylinder Type

MSHH3-32DA to 80DA

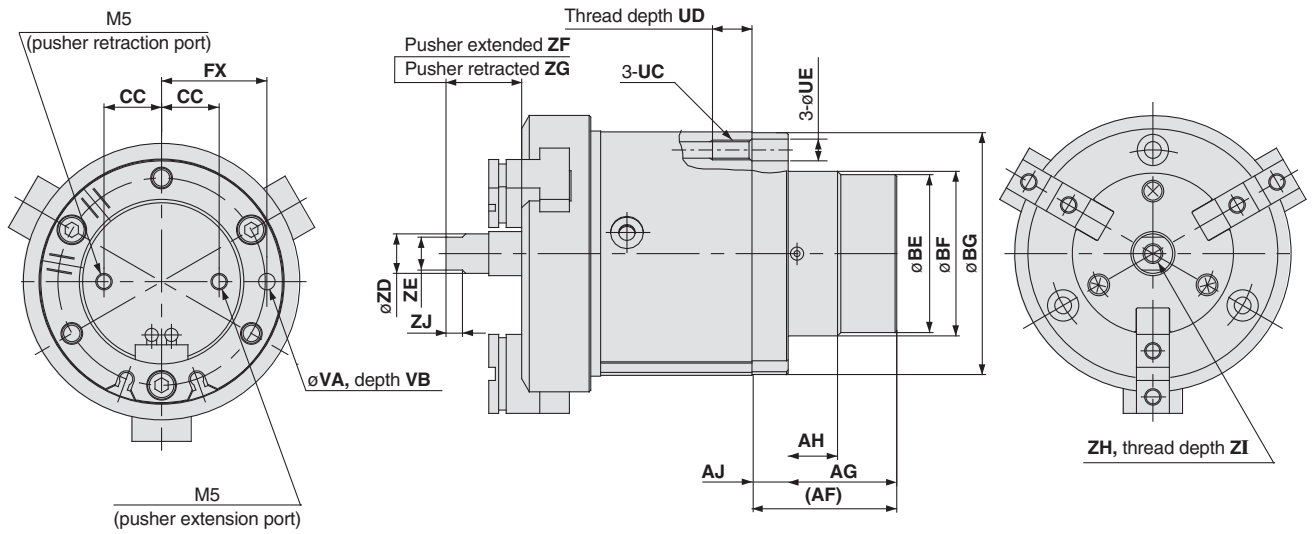

Centre pusher auto switch mounting groove positions (2 locations)

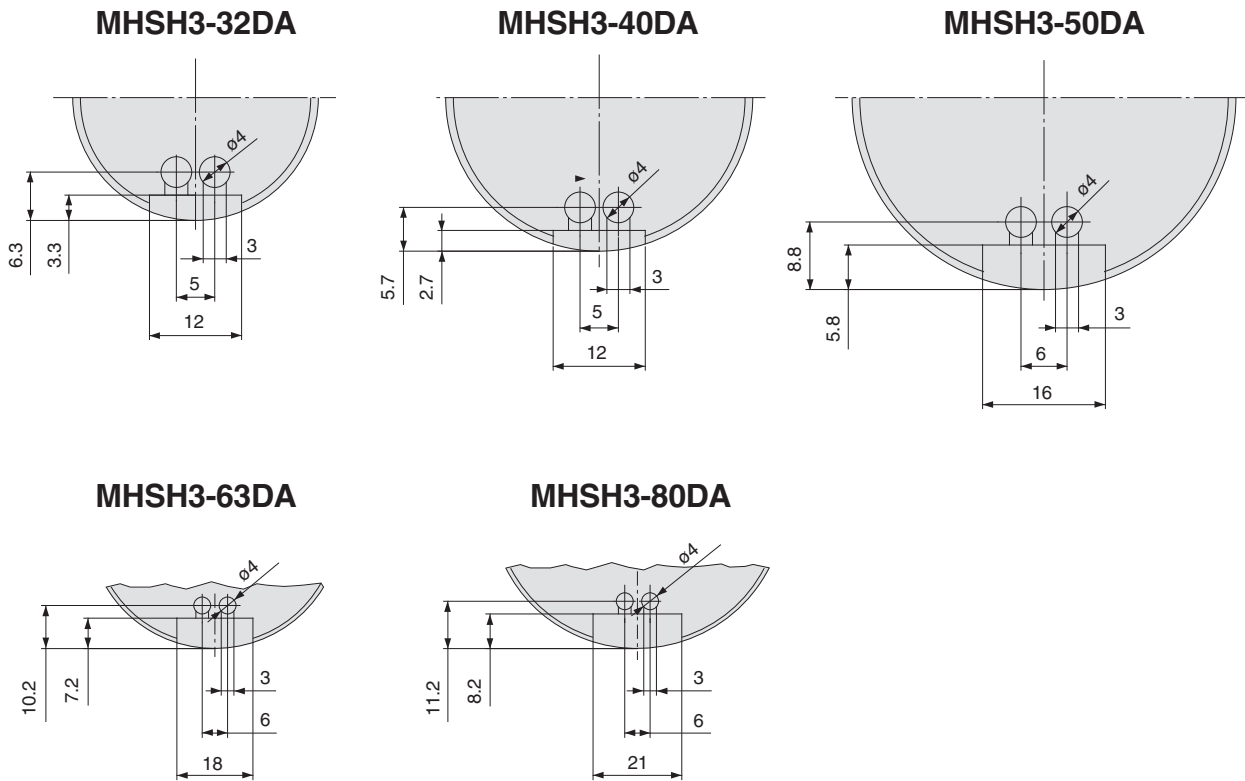

Note) For dimensions, refer to the MSHH3-32 to 80D dimensions on page 5-191

Model	AF	AG	AH	AJ	BE	BF	BG	CC	FX	UC	UD	UE	VA	VB	ZD	ZE	ZF	ZG	ZH	ZI	ZJ
MSHH3-32DA	35	26	9	9	30	32h9 ₀ ^{-0.062}	53.5	9.5	22	M5	10	5.5	4H9 ₀ ^{+0.030}	4	6	5	20	15	M3	6	3.5
MSHH3-40DA	36	27	12	9	38	40h9 ₀ ^{-0.062}	61.5	13.5	26	M5	10	5.5	4H9 ₀ ^{+0.030}	4	10	8	21	16	M5	10	4.5
MSHH3-50DA	44	33	15	11	48	50h9 ₀ ^{-0.062}	73.5	17.5	32	M6	12	6.6	5H9 ₀ ^{+0.030}	5	12	10	28	18	M6	12	5
MSHH3-63DA	48	35	18	13	58	60h9 ₀ ^{-0.074}	91.5	20	40	M8	16	8.6	6H9 ₀ ^{+0.030}	6	16	14	32	22	M8	16	7
MSHH3-80DA	58	45	20	13	68	70h9 ₀ ^{-0.074}	111.5	25	50	M8	16	8.6	6H9 ₀ ^{+0.030}	6	20	17	41	26	M10	20	8

Dimensions: Centre Pusher/Spring Type

MSH3-32DB to 80DB

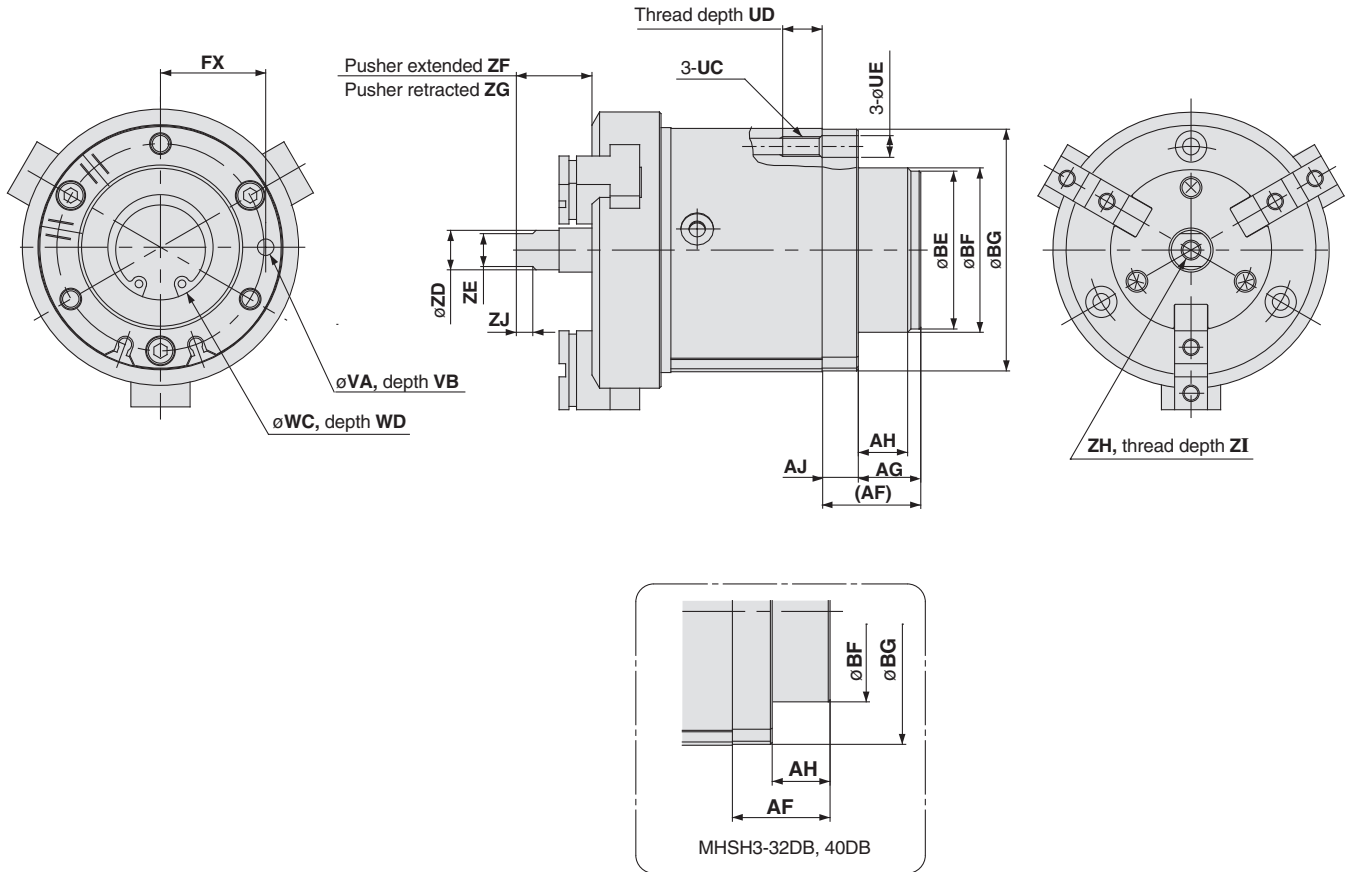

Note) For dimensions, refer to the MSH3-32 to 80D dimensions on page 5-191

Model	AF	AG	AH	AJ	BE	BF	BG	FX	UC	UD	UE	VA	VB	WC	WD	ZD	ZE	ZF	ZG
MSH3-32DB	18	—	9	9	—	32h9 ⁰ _{-0.062}	53.5	22	M5	10	5.5	4H9 ^{+0.030} ₀	4	20 ^{+0.1} ₀	1.5	6	5	20	15
MSH3-40DB	21	—	12	9	—	40h9 ⁰ _{-0.062}	61.5	26	M5	10	5.5	4H9 ^{+0.030} ₀	4	24 ^{+0.1} ₀	1.5	10	8	21	16
MSH3-50DB	30	19	15	11	48	50h9 ⁰ _{-0.062}	73.5	32	M6	12	6.6	5H9 ^{+0.030} ₀	5	32 ^{+0.1} ₀	1.5	12	10	28	18
MSH3-63DB	35	22	18	13	58	60h9 ⁰ _{-0.074}	91.5	40	M8	16	8.6	6H9 ^{+0.030} ₀	6	42 ^{+0.1} ₀	2	16	14	32	22
MSH3-80DB	48	35	20	13	68	70h9 ⁰ _{-0.074}	111.5	50	M8	16	8.6	6H9 ^{+0.030} ₀	6	52 ^{+0.1} ₀	2	20	17	41	26

Model	ZH	ZI	ZJ
MSH3-32DB	M3	6	3.5
MSH3-40DB	M5	10	4.5
MSH3-50DB	M6	12	5
MSH3-63DB	M8	16	7
MSH3-80DB	M10	20	8

Dimensions: Centre Pusher/Cylinder Type with Dust Cover

MHSHJ3-32DA to 80DA

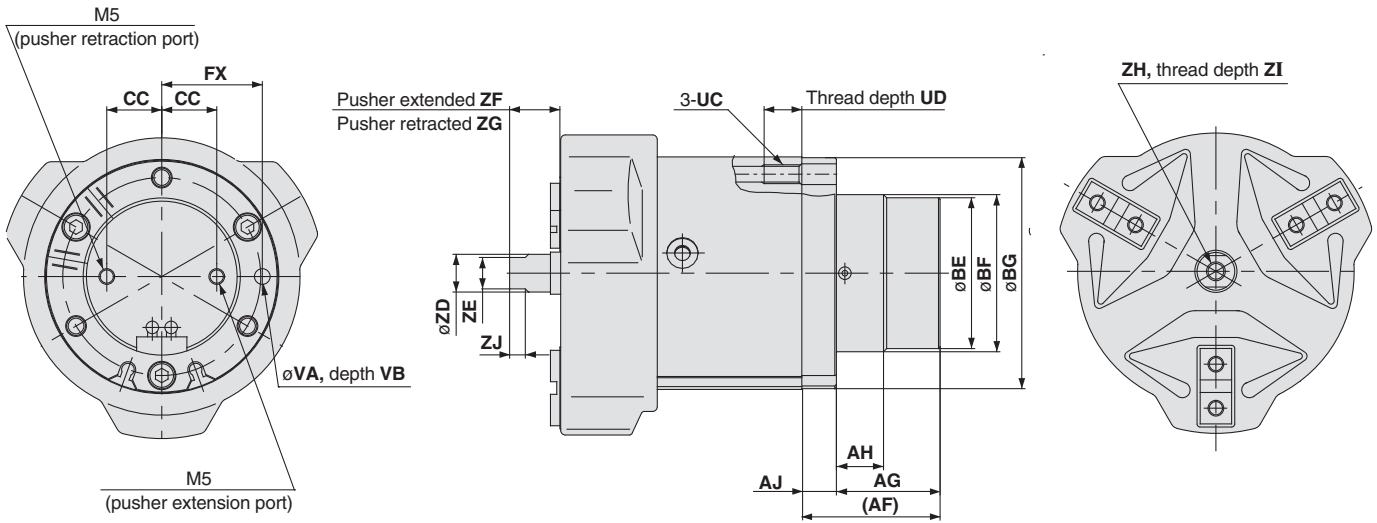

Note) For dimensions, refer to the MHSHJ3-32 to 80D dimensions on page 5-194
For auto switch mounting groove dimensions for the centre pusher, refer to MHSH3-32 to 80DA on page 5-192

Model	AF	AG	AH	AJ	BE	BF	BG	CC	FX	UC	UD	VA	VB	ZD	ZE	ZF	ZG	ZH	ZI	ZJ
MHSHJ3-32DA	35	26	9	9	30	32h9 ⁰ _{-0.062}	53.5	9.5	22	M5	10	4H9 ^{+0.030} ₀	4	6	5	14	9	M3	6	3.5
MHSHJ3-40DA	36	27	12	9	38	40h9 ⁰ _{-0.062}	61.5	13.5	26	M5	10	4H9 ^{+0.030} ₀	4	10	8	15	10	M5	10	4.5
MHSHJ3-50DA	44	33	15	11	48	50h9 ⁰ _{-0.062}	73.5	17.5	32	M6	12	5H9 ^{+0.030} ₀	5	12	10	21	11	M6	12	5
MHSHJ3-63DA	48	35	18	13	58	60h9 ⁰ _{-0.074}	91.5	20	40	M8	16	6H9 ^{+0.030} ₀	6	16	14	24	14	M8	16	7
MHSHJ3-80DA	58	45	20	13	68	70h9 ⁰ _{-0.074}	111.5	25	50	M8	16	6H9 ^{+0.030} ₀	6	20	17	31	16	M10	20	8

Series MSHJ3

Dimensions: Centre Pusher/Spring Type with Dust Cover

MHSHJ3-32DB to 80DB

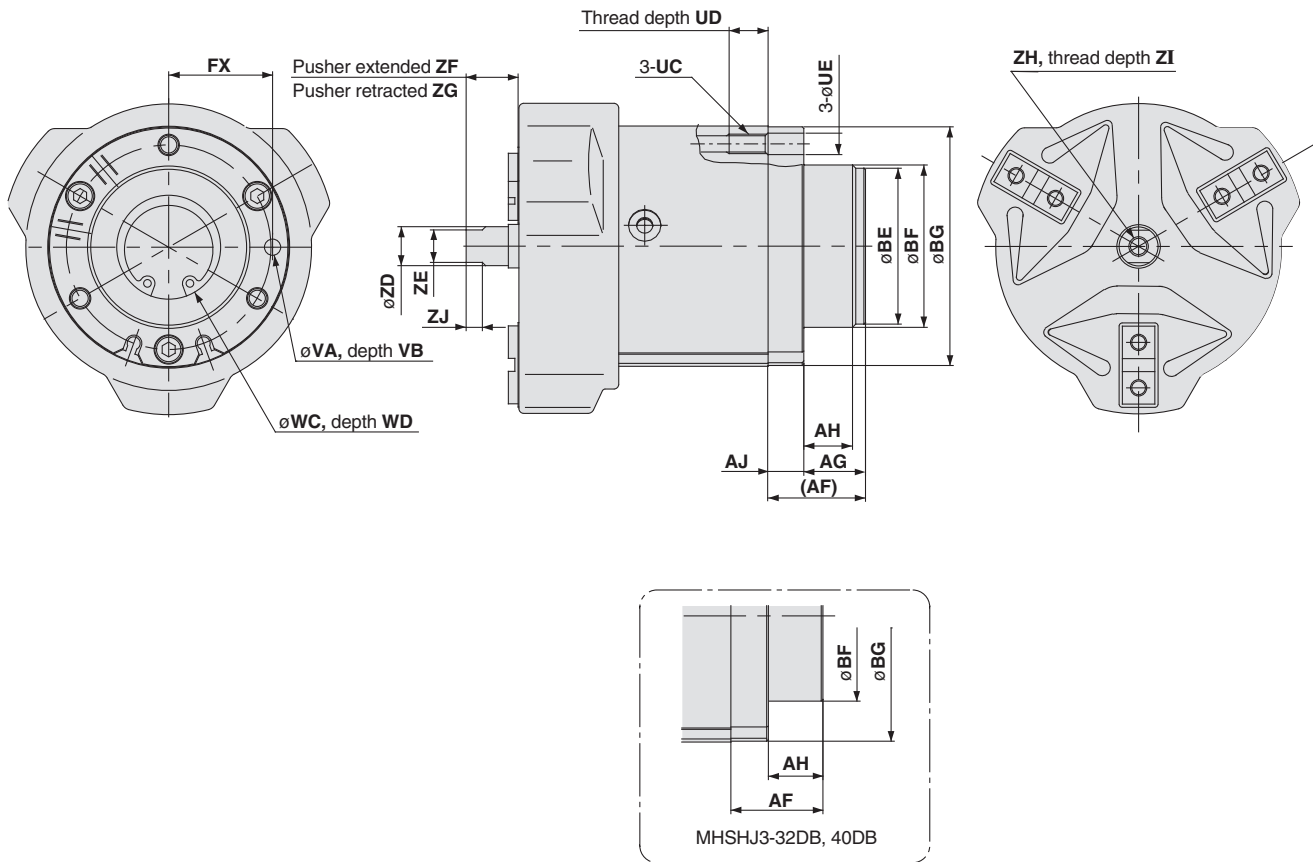

Note) For dimensions, refer to the MSHJ3-32 to 80D dimensions on page 5-194

Model	AF	AG	AH	AJ	BE	BF	BG	FX	UC	UD	UE	VA	VB	WC	WD	ZD	ZE	ZF
MHSHJ3-32DB	18	—	9	9	—	32h9 _{-0.062}	53.5	22	M5	10	5.5	4H9 ^{+0.030} ₀	4	20 ^{+0.1} ₀	1.5	6	5	14
MHSHJ3-40DB	21	—	12	9	—	40h9 _{-0.062}	61.5	26	M5	10	5.5	4H9 ^{+0.030} ₀	4	24 ^{+0.1} ₀	1.5	10	8	15
MHSHJ3-50DB	30	19	15	11	48	50h9 _{-0.062}	73.5	32	M6	12	6.6	5H9 ^{+0.030} ₀	5	32 ^{+0.1} ₀	1.5	12	10	21
MHSHJ3-63DB	35	22	18	13	58	60h9 _{-0.074}	91.5	40	M8	16	8.6	6H9 ^{+0.030} ₀	6	42 ^{+0.1} ₀	2	16	14	24
MHSHJ3-80DB	48	35	20	13	68	70h9 _{-0.074}	111.5	50	M8	16	8.6	6H9 ^{+0.030} ₀	6	52 ^{+0.1} ₀	2	20	17	31

Model	ZG	ZH	ZI	ZJ
MHSHJ3-32DB	9	M3	6	3.5
MHSHJ3-40DB	10	M5	10	4.5
MHSHJ3-50DB	11	M6	12	5
MHSHJ3-63DB	14	M8	16	7
MHSHJ3-80DB	16	M10	20	8

**3 Finger
Air Gripper
Parallel Type
Long Stroke**

Series MHS L3

ø16, ø20, ø25, ø32, ø40, ø50, ø63, ø80, ø100, ø125

How to Order

Cylinder Bore Size

ø16 to ø25 **MHSL 3-20 D-M9N**

- Long Stroke**
- Number of fingers**
3 | 3 fingers
- Cylinder bore size**
16 | 16mm
20 | 20mm
25 | 25mm
- Number of auto switches**
Nil | 2 pcs.
S | 1 pc.
- Auto switch type**
Without auto switch (built-in magnet)
For details see table below
- Action**
D | Double acting

Cylinder Bore Size

ø32 to ø125 **MHSL 3-50 D-M9N**

- Long Stroke**
- Number of fingers**
3 | 3 fingers
- Cylinder bore size**
32 | 32mm
40 | 40mm
50 | 50mm
63 | 63mm
80 | 80mm
100 | 100mm
125 | 125mm
- Number of auto switches**
Nil | 2 pcs.
S | 1 pc.
n | "n" pcs.
- Auto switch type**
Nil | Without auto switch (built-in magnet)
- Action**
D | Double acting
- Port thread type**
Symbol | Type | Size
Nil | M thread | ø32 to ø63
Rc | ø80 to ø125
TN | NPT | ø80 to ø125
TF | G | ø80 to ø125

Symbol

Applicable Auto Switches

Type	Special function	Electrical entry	Indicator light	Wiring (Output)	Load voltage		Auto switch model		Lead wire length (m)*				Pre-wired connector	Applicable load		
					DC	AC	Electrical entry direction		0.5 (Nil)	1 (M)	3 (L)	5 (Z)				
							Perpendicular	In-line								
Solid state auto switch	—	Grommet	Yes	3-wire (NPN)	5 V, 12 V	—	M9NV	M9N	●	●	○	○	IC circuit	Relay, PLC		
							F8N	—	●	—	●	○			—	
				3-wire (PNP)	M9PV	M9P	●	●	●	○	○					
					F8P	—	●	—	●	○	—					
				2-wire	12 V	M9BV	M9B	●	●	●	○	○				
					F8B	—	●	—	●	○	—					
	Diagnosis (2-colour indication)			3-wire (NPN)	5 V, 12 V	—	M9N WV	M9N W	●	●	●	○	○		○	IC circuit
							M9P WV	M9P W	●	●	●	○	○		○	
				3-wire (PNP)	12 V	M9B WV	M9B W	●	●	●	○	○	○		—	
					5 V, 12 V	M9NAV**	M9NA**	○	○	●	○	○	○		IC circuit	
				2-wire	5 V, 12 V	M9PAV**	M9PA**	○	○	●	○	○	○			—
					12 V	M9BAV**	M9BA**	○	○	●	○	○	○		—	

** Water resistant type auto switches can be mounted on the above models, but in such case SMC cannot guarantee water resistance.

* Lead wire length symbols: 0.5 m Nil (Example) M9N W
1 m M (Example) M9N W M
3 m L (Example) M9N W L
5 m Z (Example) M9N W Z

* Solid state auto switches marked with ○ are produced upon receipt of order.

Note 1) When using the 2-color indicator type, please make the setting so that the indicator is lit in red to ensure the detection at the proper position of the air gripper.

Note 2) When ordering the air gripper with auto switch, auto switch mounting brackets are supplied with the air gripper having a bore size of ø32 to ø125.

When ordering the auto switch separately, auto switch mounting brackets (BMG2-012) are required for bore size of ø32 to ø125.

Series MHSL3

Models and Specifications



Model	MHSL3-16D	MHSL3-20D	MHSL3-25D	MHSL3-32D	MHSL3-40D	MHSL3-50D	MHSL3-63D	MHSL3-80D	MHSL3-100D	MHSL3-125D																						
Cylinder bore size mm	16	20	25	32	40	50	63	80	100	125																						
Fluid	Air																															
Operating pressure MPa	0.2 to 0.6					0.1 to 0.6																										
Ambient and fluid temperature °C	-10 to 60																															
Repeatability mm	±0.01																															
Max. operating frequency c.p.m.	120					60			30																							
Lubrication	Non-lube																															
Action	Double acting																															
Effective gripping force N at pressure of 0.5MPa	<table border="1"> <thead> <tr> <th>External gripping force</th> <th>Internal gripping force</th> </tr> </thead> <tbody> <tr> <td>14</td> <td>16</td> </tr> <tr> <td>25</td> <td>28</td> </tr> <tr> <td>42</td> <td>47</td> </tr> <tr> <td>74</td> <td>82</td> </tr> <tr> <td>118</td> <td>130</td> </tr> <tr> <td>187</td> <td>204</td> </tr> <tr> <td>335</td> <td>359</td> </tr> <tr> <td>500</td> <td>525</td> </tr> <tr> <td>750</td> <td>780</td> </tr> <tr> <td>1,270</td> <td>1,320</td> </tr> </tbody> </table>										External gripping force	Internal gripping force	14	16	25	28	42	47	74	82	118	130	187	204	335	359	500	525	750	780	1,270	1,320
External gripping force	Internal gripping force																															
14	16																															
25	28																															
42	47																															
74	82																															
118	130																															
187	204																															
335	359																															
500	525																															
750	780																															
1,270	1,320																															
Opening/closing stroke mm (diameter)	10	10	12	16	20	28	32	40	48	64																						
Weight g	80	135	180	370	550	930	1,550	2,850	5,500	11,300																						

Note 1) Values for $\phi 16$ to $\phi 25$ are with gripping point $L = 20\text{mm}$, for $\phi 32$ to $\phi 63$ with gripping point $L = 30\text{mm}$, and for $\phi 80$ to $\phi 125$ with gripping point $L = 50\text{mm}$.

Refer to the "Effective Gripping Force" data on pages 5-199 through 5-201 for the gripping force at each gripping position.

Note 2) Open and closed diameter values apply for external gripping of work pieces.

Construction

Closed condition

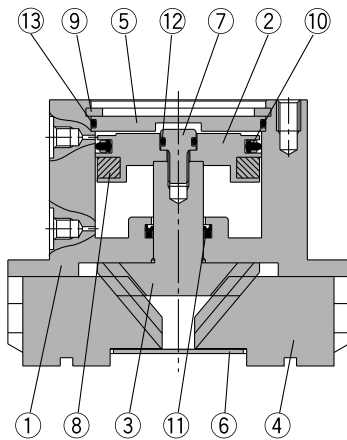

Open condition

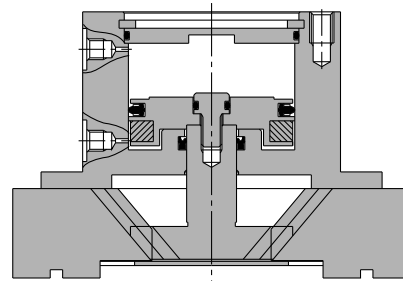

Parts list

No.	Description	Material	Note
1	Body	Aluminum alloy	Hard anodized
2	Piston	Aluminum alloy	Hard anodized
3	Cam	Carbon steel	Heat treated, Specially treated
4	Finger	Carbon steel	Heat treated, Specially treated
5	Cap	Aluminum alloy	Hard anodized
6	End plate	Stainless steel	
7	Piston bolt	Stainless steel	

No.	Description	Material	Note
8	Rubber magnet	Synthetic rubber	
9	C type snap ring	Carbon steel	Nickel plated
10	Piston seal	NBR	
11	Rod seal	NBR	
12	Gasket	NBR	
13	Gasket	NBR	

Replacement parts/Seal kits

Kit Number										Contents
MHSL3-16D	MHSL3-20D	MHSL3-25D	MHSL3-32D	MHSL3-40D	MHSL3-50D	MHSL3-63D	MHSL3-80D	MHSL3-100D	MHSL3-125D	
MHSL16-PS	MHSL20-PS	MHSL25-PS	MHSL32-PS	MHSL40-PS	MHSL50-PS	MHSL63-PS	MHSL80-PS	MHSL100-PS	MHSL125-PS	A set of the above Nos. 10, 11, 12 and 13

* Seal kits are sets consisting of items 10, 11, 12 and 13, which can be ordered using the kit number for each cylinder bore size.

Gripping Point

- The work piece gripping point distance should be within the gripping force ranges given for each pressure in the effective gripping force graphs below.
- If operated with the work piece gripping point beyond the indicated ranges, an excessive offset load will be applied to the sliding section of the fingers, which can have an adverse effect on the service life of the product.

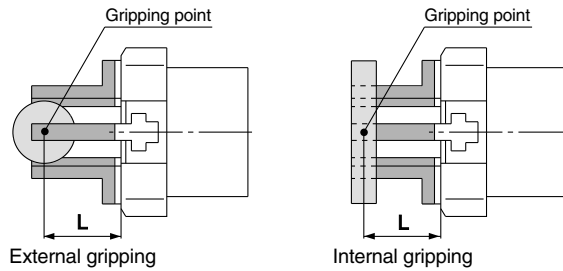

L: Gripping point distance

Effective Gripping Force

- Expressing the effective gripping force
- The effective gripping force shown in the graphs to the right is expressed as F, which is the impellent force of one finger when all 3 of the fingers and attachments are in full contact with the work piece as shown in the figure below.

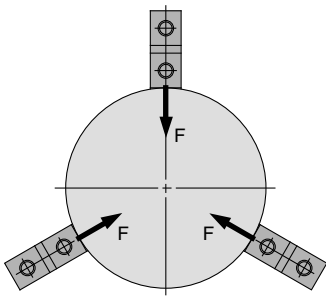

External gripping

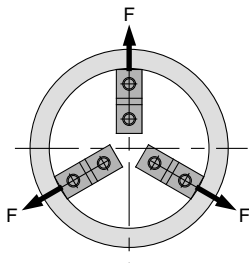

Internal gripping

1N: Approx. 0.102kgf
1MPa: Approx. 10.2kgf/cm²

External gripping force

MHSL3-16D

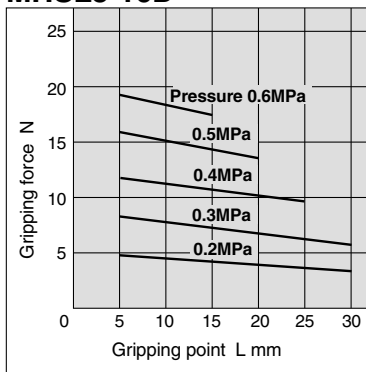

MHSL3-20D

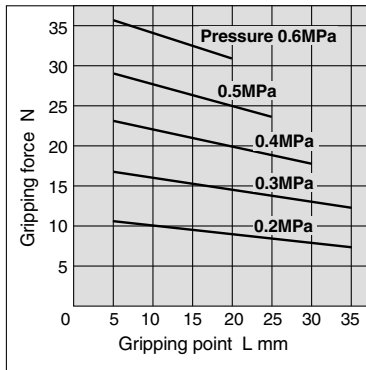

MHSL3-25D

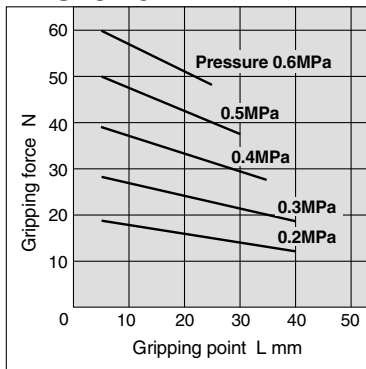

Internal gripping force

MHSL3-16D

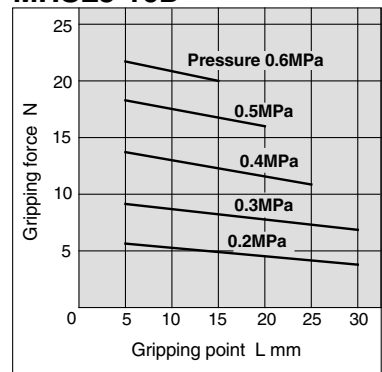

MHSL3-20D

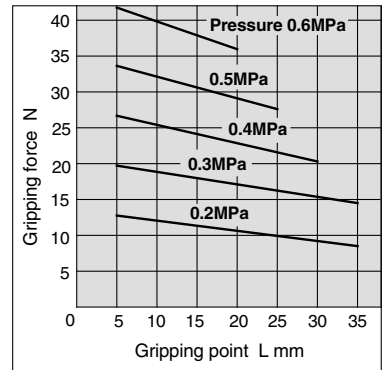

MHSL3-25D

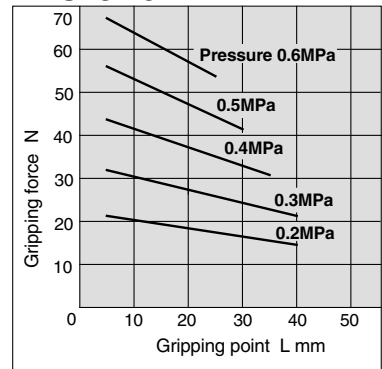

Series MHSL3

Effective Gripping Force

- Expressing the effective gripping force
The effective gripping force shown in the graphs to the right is expressed as F, which is the impellent force of one finger when all 3 of the fingers and attachments are in full contact with the work piece as shown in the figure below.

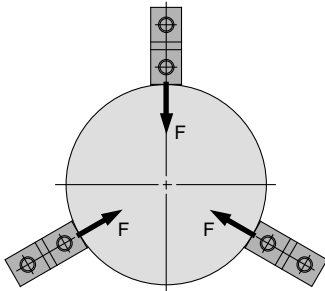

External gripping

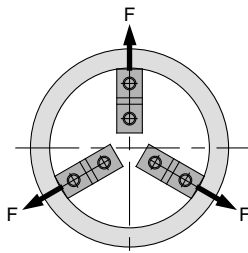

Internal gripping

1N: Approx. 0.102kgf
1MPa: Approx. 10.2kgf/cm²

External gripping force

MHSL3-32 D

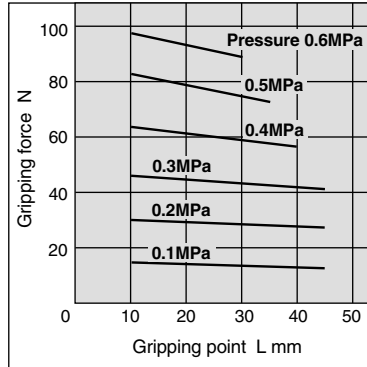

MHSL3-40 D

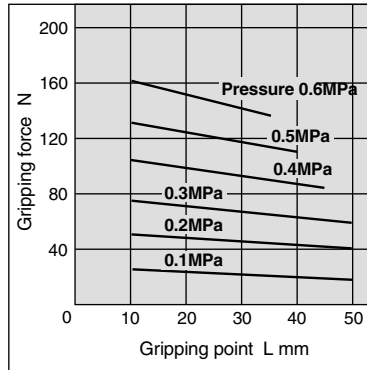

MHSL3-50 D

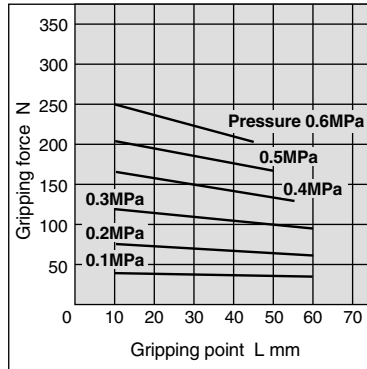

MHSL3-63 D

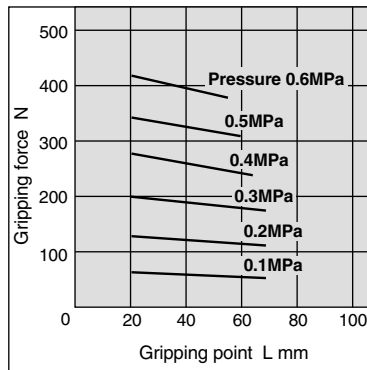

Internal gripping force

MHSL3-32 D

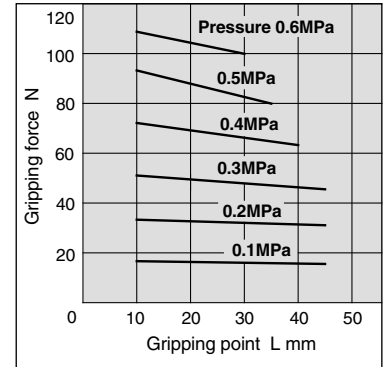

MHSL3-40 D

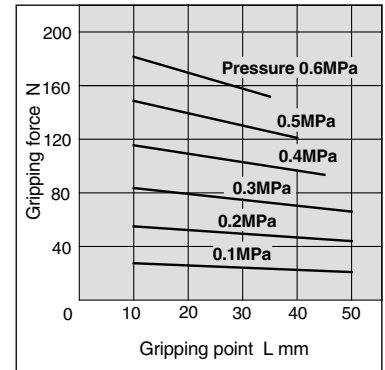

MHSL3-50 D

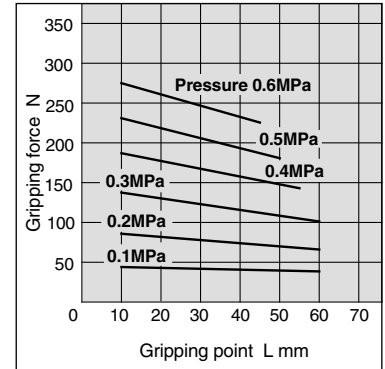

MHSL3-63 D

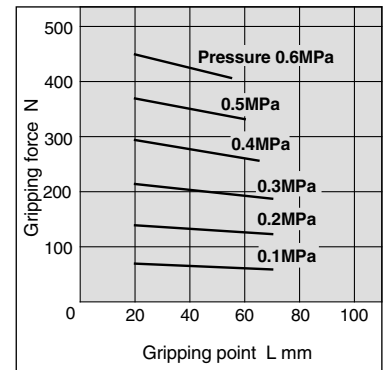

External gripping force

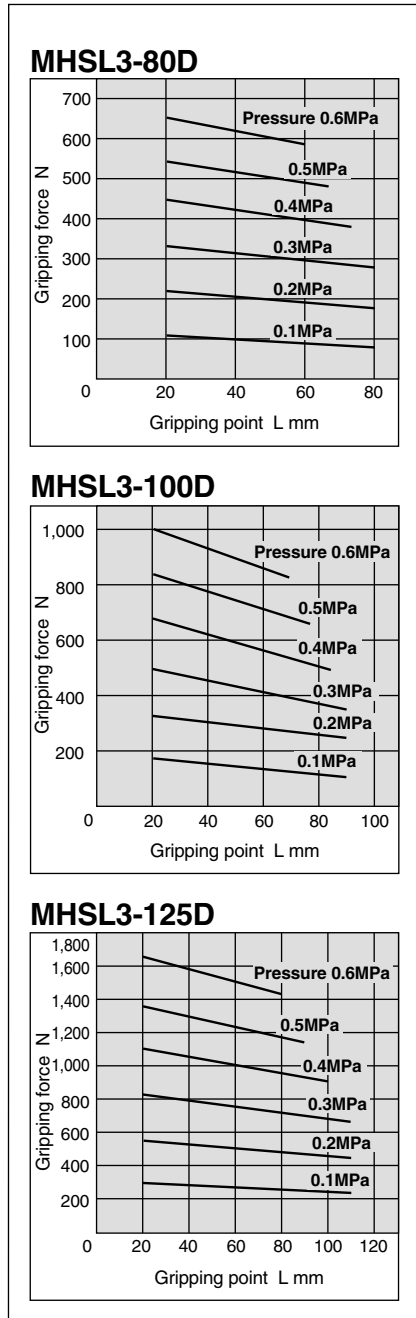

Internal gripping force

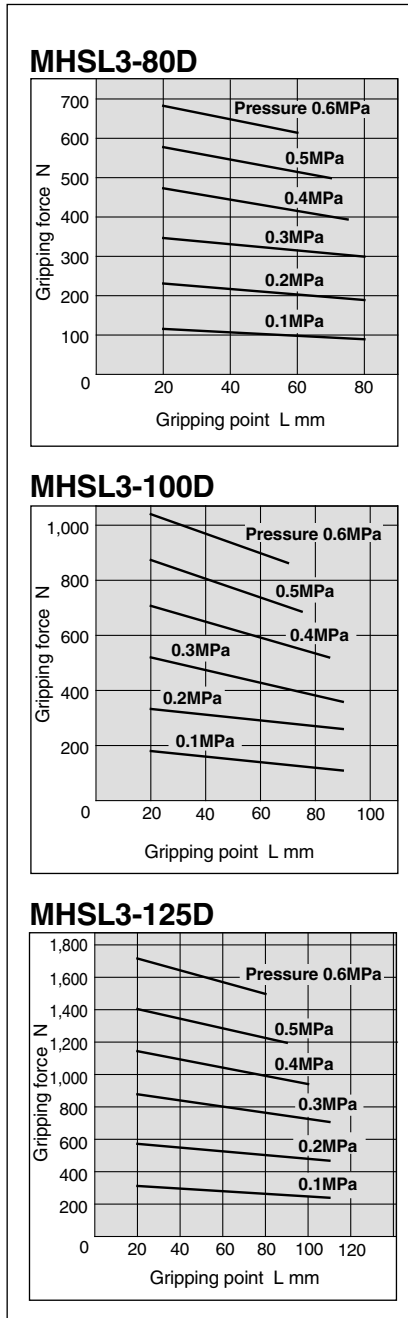

MHSL3-32D to 80D

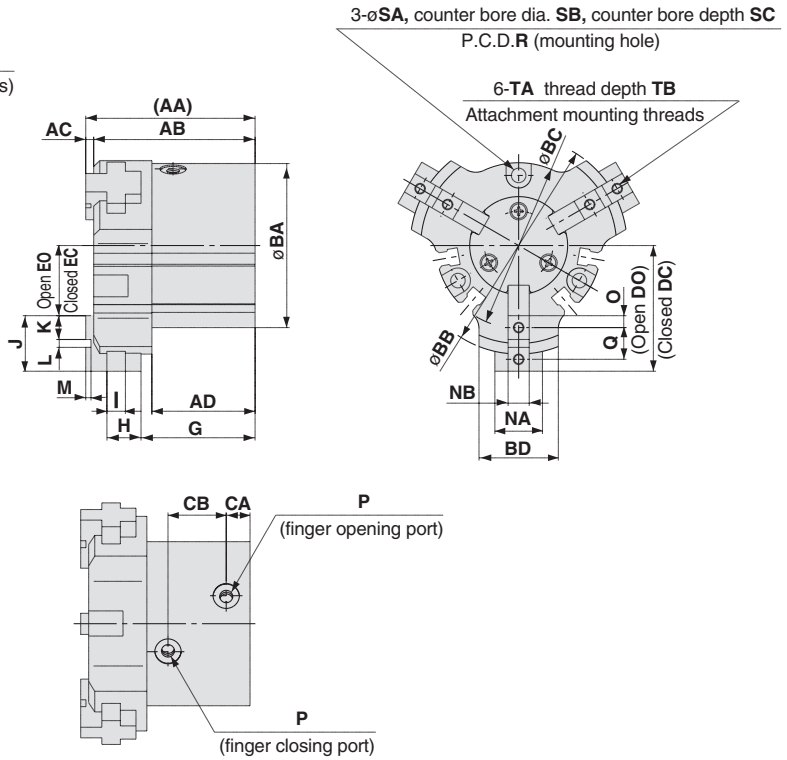
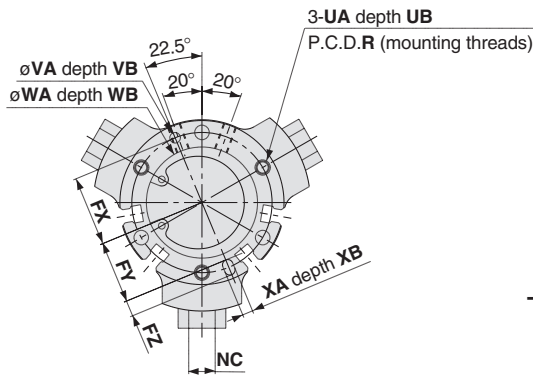

Auto switch mounting groove positions (4 locations)

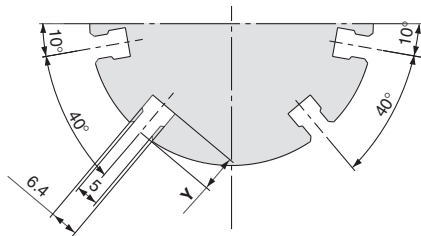

Auto switch mounting groove positions

Mounting hole counter bore dimensions
MHSL3-32D

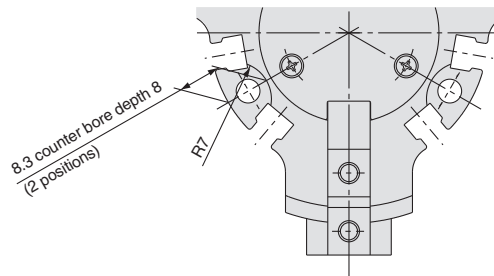

Note) The counter bore configuration differs only for the mounting hole section between the auto switch mounting grooves. (ø32 only)

Model	AA	AB	AC	AD	BA	BB	BC	BD	CA	CB	DO	DC	EO	EC	FX	FY	FZ	G	H	I	J	K
MHSL3-32D	58	55	3	35.5	52	72	52.6	24	8	20	42	34	22	14	22	19.5	5	39.6	10.4	5	20	9
MHSL3-40D	64	61	3	38.5	62	82	62.6	30	9	22	47.5	37.5	26.5	16.5	26.5	23.5	6	42.5	13.5	7	21	9
MHSL3-50D	77.5	74.5	3	46.5	70	104	70.6	32	9	29	60	46	36	22	31	28	6	51.3	17.7	8	24	10
MHSL3-63D	89	85	4	51	86	120	86.6	40	12	30.5	70	54	42	26	38	34.5	7	58.5	19.5	10	28	11
MHSL3-80D	116	111	5	70	106	140	106.6	50	14	37.5	80.5	60.5	48.5	28.5	47.5	43.5	8	78.5	23.5	11	32	12

Model	L	M	NA	NB	NC	O	P	Q	R	SA	SB	SC	TA	TB	UA	UB	VA	VB
MHSL3-32D	2H9 ^{+0.025} ₀	2	16	8h9 ⁰ _{-0.036}	10	4.5	M5	11	44	4.5	8	8	M4	8	M4	6	3H9 ^{+0.025} ₀	3
MHSL3-40D	3H9 ^{+0.025} ₀	2	18	8h9 ⁰ _{-0.036}	10	4.5	M5	12	53	5.5	9.5	9.5	M4	8	M5	10	4H9 ^{+0.030} ₀	4
MHSL3-50D	4H9 ^{+0.030} ₀	2	20	10h9 ⁰ _{-0.036}	12	5	M5	14	62	5.5	9.5	9.5	M5	10	M5	10	4H9 ^{+0.030} ₀	4
MHSL3-63D	6H9 ^{+0.036} ₀	3	26	12h9 ⁰ _{-0.043}	14	5.5	M5	17	76	6.6	11	17	M5	10	M6	12	5H9 ^{+0.030} ₀	5
MHSL3-80D	8H9 ^{+0.036} ₀	4	30	14h9 ⁰ _{-0.043}	16	6	Rc 1/8	20	95	6.6	11	23	M6	12	M6	12	6H9 ^{+0.030} ₀	6

Model	WA	WB	XA	XB	Y
MHSL3-32D	34H9 ^{+0.062} ₀	2	3H9 ^{+0.025} ₀	3	6
MHSL3-40D	42H9 ^{+0.062} ₀	2	4H9 ^{+0.030} ₀	4	8
MHSL3-50D	52H9 ^{+0.074} ₀	2	4H9 ^{+0.030} ₀	4	7
MHSL3-63D	65H9 ^{+0.074} ₀	2.5	5H9 ^{+0.030} ₀	5	7.5
MHSL3-80D	82H9 ^{+0.087} ₀	3	6H9 ^{+0.030} ₀	6	9

Series MHSL3

Dimensions

MHSL3-100D, 125D

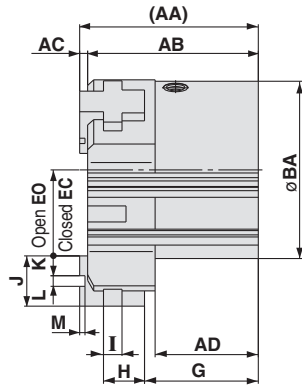
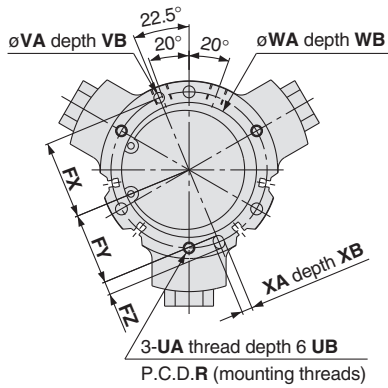

3- ϕSA , counter bore dia. SB, counter bore depth SC
P.C.D.R (mounting hole)
6-TA thread depth TB
(attachment mounting threads)

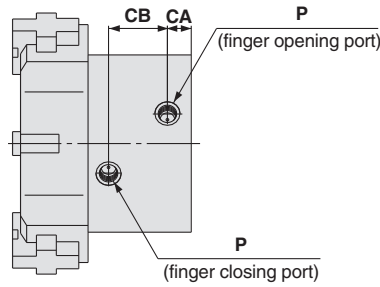
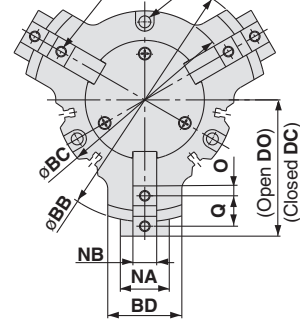

MHSL3-100D

MHSL3-125D

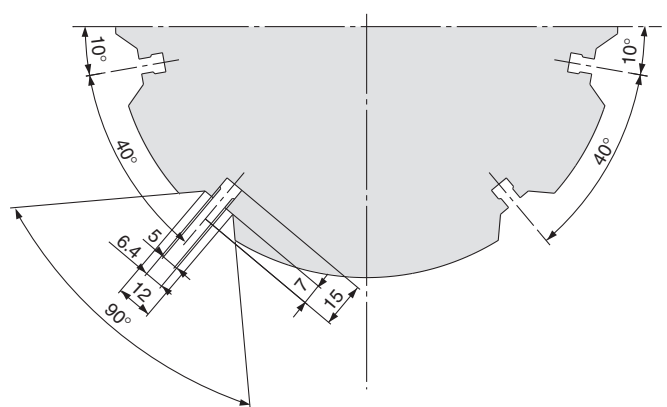
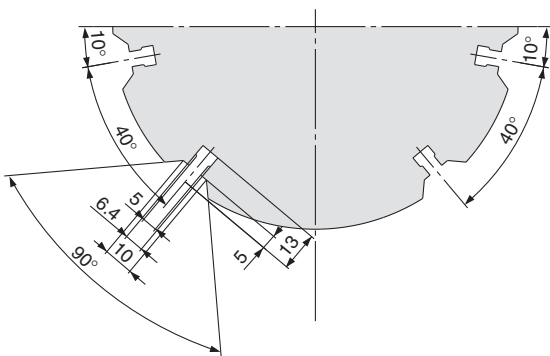

(mm)

Model	AA	AB	AC	AD	BA	BB	BC	BD	CA	CB	DO	DC	EO	EC	FX	FY	FZ	G	H	I	J	K
MHSL3-100D	135	129	6	78	134	184	134.6	56	18	44.5	103	79	65	41	59	54	10	86	31	14	38	15
MHSL3-125D	175	167	8	102	166	234	166.6	66	24	54	132	100	80	48	74	68	12	112	43	17	52	21

Model	L	M	NA	NB	NC	O	P	Q	R	SA	SB	SC	TA	TB	UA	UB	VA
MHSL3-100D	8H9 ^{+0.036} ₀	4	37	18h9 ₀ ^{0.043}	21	7.5	Rc 1/4	23	118	9	14	31	M8	16	M8	16	8H9 ^{+0.036} ₀
MHSL3-125D	10H9 ^{+0.036} ₀	6	43	22h9 ₀ ^{0.052}	25	10.5	Rc 3/8	31	148	11	17.5	32	M10	20	M10	20	10H9 ^{+0.036} ₀

Model	VB	WA	WB	XA	XB
MHSL3-100D	6	102H9 ^{+0.087} ₀	4	8H9 ^{+0.036} ₀	6
MHSL3-125D	8	130H9 ^{+0.100} ₀	6	10H9 ^{+0.036} ₀	8

4 Finger Air Gripper Parallel Type

Series MHS4

∅16, ∅20, ∅25, ∅32, ∅40, ∅50, ∅63

How to Order

Cylinder Bore Size

∅16 to ∅25 **MHS 4 - 20 D - M9N**

Number of fingers

4	4 fingers
---	-----------

Cylinder bore size

16	16mm
20	20mm
25	25mm

Action

D	Double acting
---	---------------

Number of auto switches

Nil	2 pcs.
S	1 pc.

Auto switch type

Nil	Without auto switch (built-in magnet)
-----	---------------------------------------

For details see table below

Cylinder Bore Size

∅32 to ∅63 **MHS 4 - 50 D - M9N**

Number of fingers

4	4 fingers
---	-----------

Cylinder bore size

32	32mm
40	40mm
50	50mm
63	63mm

Action

D	Double acting
---	---------------

Number of auto switches

Nil	2 pcs.
S	1 pc.

Auto switch type

Nil	Without auto switch (built-in magnet)
-----	---------------------------------------

Symbol

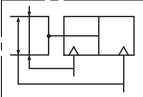

Applicable Auto Switches

Type	Special function	Electrical entry	Indicator light	Wiring (Output)	Load voltage		Auto switch model		Lead wire length (m)*				Pre-wired connector	Applicable load	
					DC	AC	Electrical entry direction		0.5 (Nil)	1 (M)	3 (L)	5 (Z)			
							Perpendicular	In-line							
Solid state auto switch	—	Grommet	Yes	3-wire (NPN)	24 V	5 V, 12 V	—	M9NV	M9N	●	●	●	○	○	IC circuit
				3-wire (PNP)				F8N	—	●	—	●	○	—	
				2-wire				M9PV	M9P	●	●	●	○	○	
				3-wire (NPN)				F8P	—	●	—	●	○	—	
				3-wire (PNP)				M9BV	M9B	●	●	●	○	○	
				2-wire				F8B	—	●	—	●	○	—	
	Diagnosis (2-colour indication)	Grommet	Yes	3-wire (NPN)	24 V	5 V, 12 V	—	M9NWV	M9NW	●	●	●	○	○	IC circuit
				3-wire (PNP)				M9PWV	M9PW	●	●	●	○	○	
				2-wire				M9B WV	M9BW	●	●	●	○	○	
				3-wire (NPN)				M9NAV**	M9NA**	○	○	●	○	○	
				3-wire (PNP)				M9PAV**	M9PA**	○	○	●	○	○	
				2-wire				M9BAV**	M9BA**	○	○	●	○	○	

** Water resistant type auto switches can be mounted on the above models, but in such case SMC cannot guarantee water resistance.

* Lead wire length symbols: 0.5 m Nil (Example) M9NW
 1 m M (Example) M9NWM
 3 m L (Example) M9NWL
 5 m Z (Example) M9NWZ

* Solid state auto switches marked with ○ are produced upon receipt of order.

Note 1) When using the 2-color indicator type, please make the setting so that the indicator is lit in red to ensure the detection at the proper position of the air gripper.

Note 2) When ordering the air gripper with auto switch, auto switch mounting brackets are supplied with the air gripper.
 When ordering the auto switch separately, auto switch mounting brackets (BMG2-012) are required.

Series MHS4

Models and Specifications



Model	MHS4-16D	MHS4-20D	MHS4-25D	MHS4-32D	MHS4-40D	MHS4-50D	MHS4-63D		
Cylinder bore size mm	16	20	25	32	40	50	63		
Fluid	Air								
Operating pressure MPa	0.2 to 0.6			0.1 to 0.6					
Ambient and fluid temperature °C	-10 to 60								
Repeatability mm	±0.01								
Max. operating frequency c.p.m.	120			60					
Lubrication	Non-lube								
Action	Double acting								
Effective gripping force N at pressure of 0.5MPa	External gripping force		10	19	31	55	88	140	251
	Internal gripping force		12	21	35	61	97	153	268
Opening/closing stroke mm	4	4	6	8	8	12	16		
Weight g	66	110	154	300	390	590	1,095		

Note) Values for $\phi 16$ to $\phi 25$ are with gripping point L = 20mm, and for $\phi 32$ to $\phi 63$ with gripping point L = 30mm.
Refer to the "Effective Gripping Force" data for the gripping force at each gripping position.

Construction

Closed condition

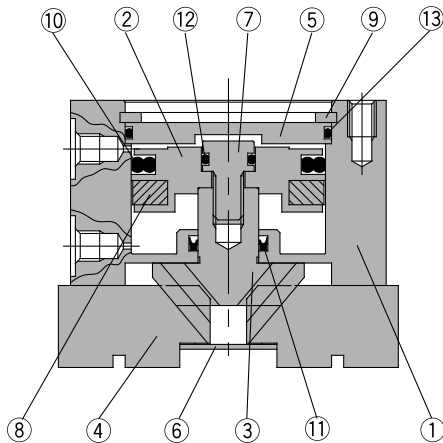

Open condition

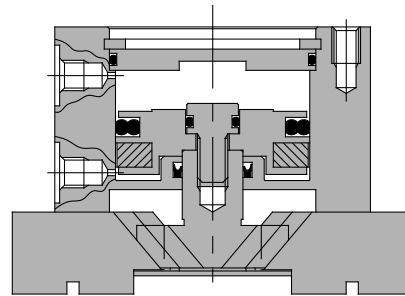

Parts list

No.	Description	Material	Note
1	Body	Aluminum alloy	Hard anodized
2	Piston	Aluminum alloy	Hard anodized
3	Cam	Carbon steel	Heat treated, Specially treated
4	Finger	Carbon steel	Heat treated, Specially treated
5	Cap	Aluminum alloy	Hard anodized
6	End plate	Stainless steel	
7	Piston bolt	Stainless steel	

No.	Description	Material	Note
8	Rubber magnet	Synthetic rubber	
9	C type snap ring	Carbon steel	Nickel plated
10	Piston seal	NBR	
11	Rod seal	NBR	
12	Gasket	NBR	
13	Gasket	NBR	

Replacement parts/Seal kits

Kit number							Contents
MHS4-16D	MHS4-20D	MHS4-25D	MHS4-32D	MHS4-40D	MHS4-50D	MHS4-63D	
MHS16-PS	MHS20-PS	MHS25-PS	MHS32-PS	MHS40-PS	MHS50-PS	MHS63-PS	A set of the above Nos. 10, 11, 12 and 13

□ Seal kits are sets consisting of items 10, 11, 12 and 13, which can be ordered using the kit number for each cylinder bore size.

Gripping Point

- The work piece gripping point distance should be within the gripping force ranges given for each pressure in the effective gripping force graphs below.
- If operated with the work piece gripping point beyond the indicated ranges, an excessive offset load will be applied to the sliding section of the fingers, which can have an adverse effect on the service life of the product.

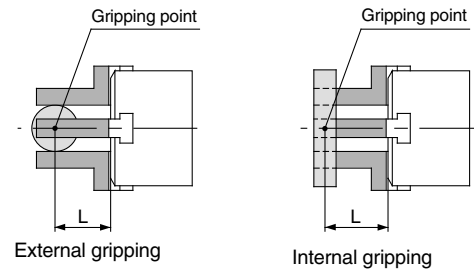

L: Gripping point distance

Effective Gripping Force

- Expressing the effective gripping force
- The effective gripping force shown in the graphs to the right is expressed as F, which is the impellent force of one finger when all four of the fingers and attachments are in full contact with the work piece as shown in the figure below. If only one of the two pairs of opposing fingers are used for gripping work pieces, while the other pair is used for another function such as positioning, the gripping force of the Series MHS4 will be the same as that of the Series MHS2.

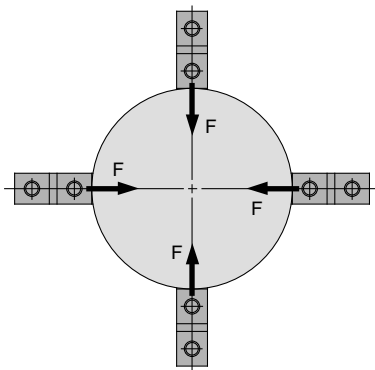

External gripping

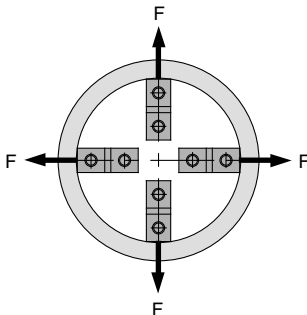

Internal gripping

1N: Approx. 0.102kgf
1MPa: Approx. 10.2kgf/cm²

External gripping force

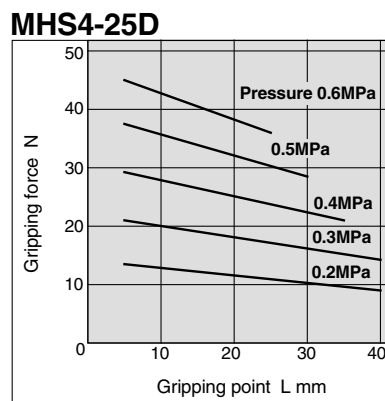
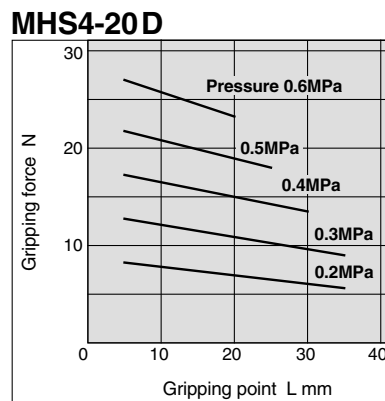
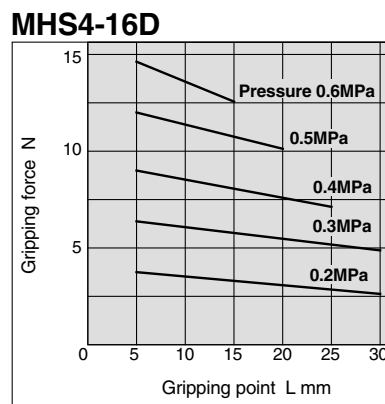

Internal gripping force

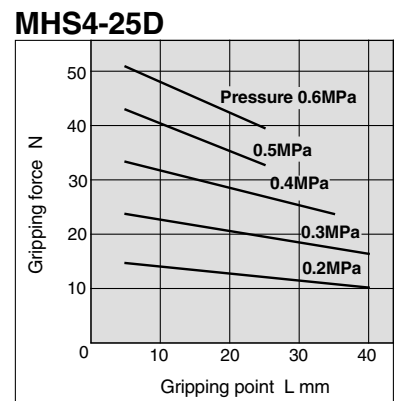
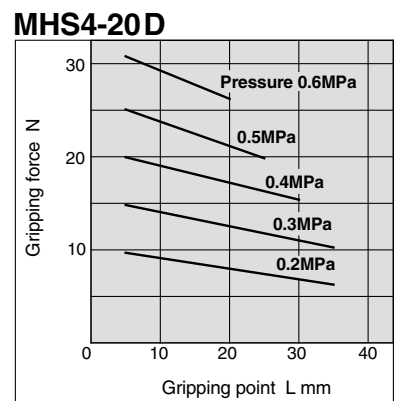
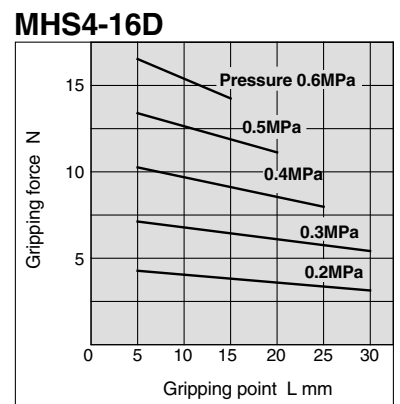

Series MHS4

Effective Gripping Force

• Expressing the effective gripping force
 The effective gripping force shown in the graphs to the right is expressed as F , which is the impellent force of one finger when all four of the fingers and attachments are in full contact with the work piece as shown in the figure below. If only one of the two pairs of opposing fingers are used for gripping work pieces, while the other pair is used for another function such as positioning, the gripping force of the Series MHS4 will be the same as that of the Series MHS2.

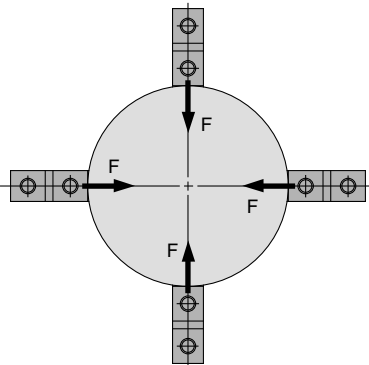

External gripping

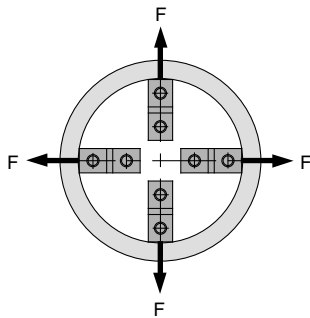

Internal gripping

1N: Approx. 0.102kgf
 1MPa: Approx. 10.2kgf/cm²

External gripping force

MHS4-32D

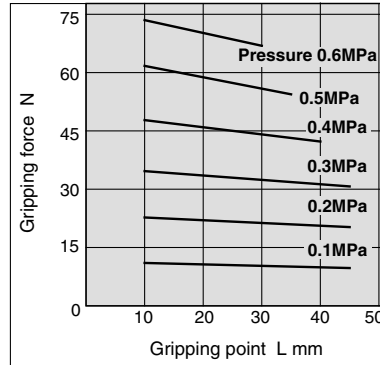

MHS4-40D

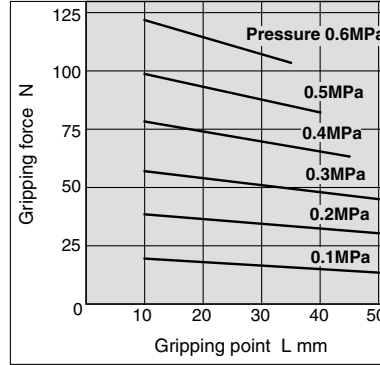

MHS4-50D

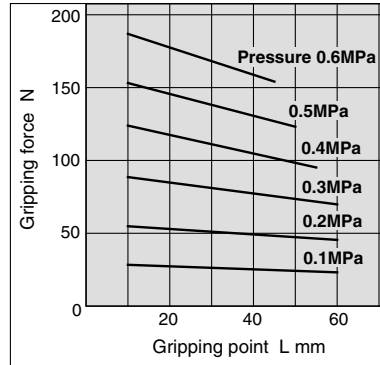

MHS4-63D

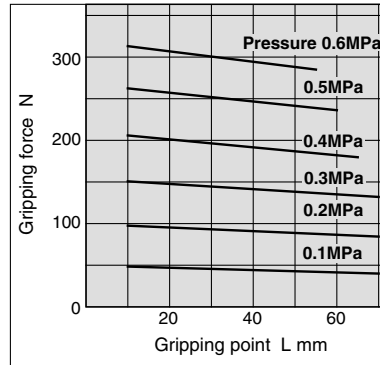

Internal gripping force

MHS4-32D

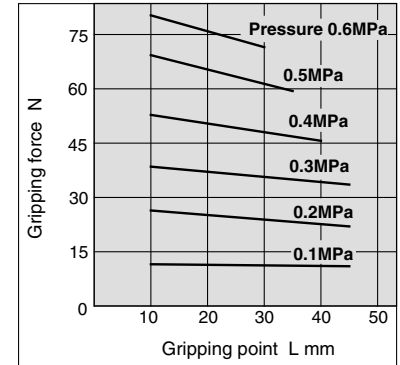

MHS4-40D

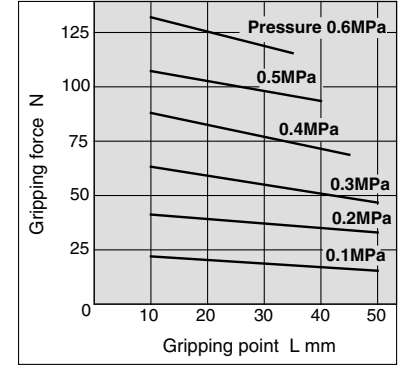

MHS4-50D

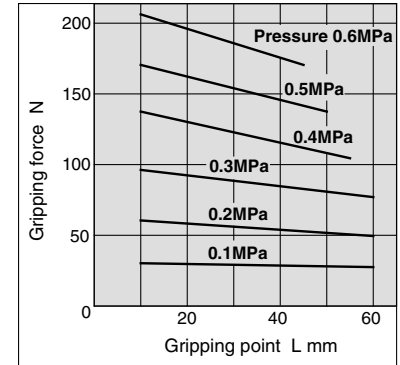

MHS4-63D

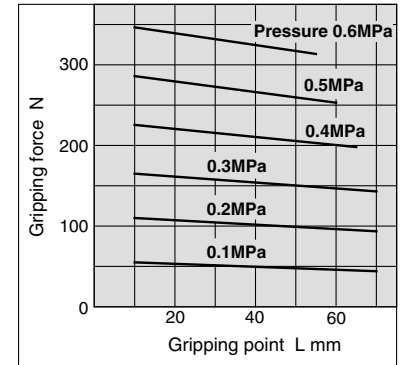

Dimensions

MHS4-16D to 25D

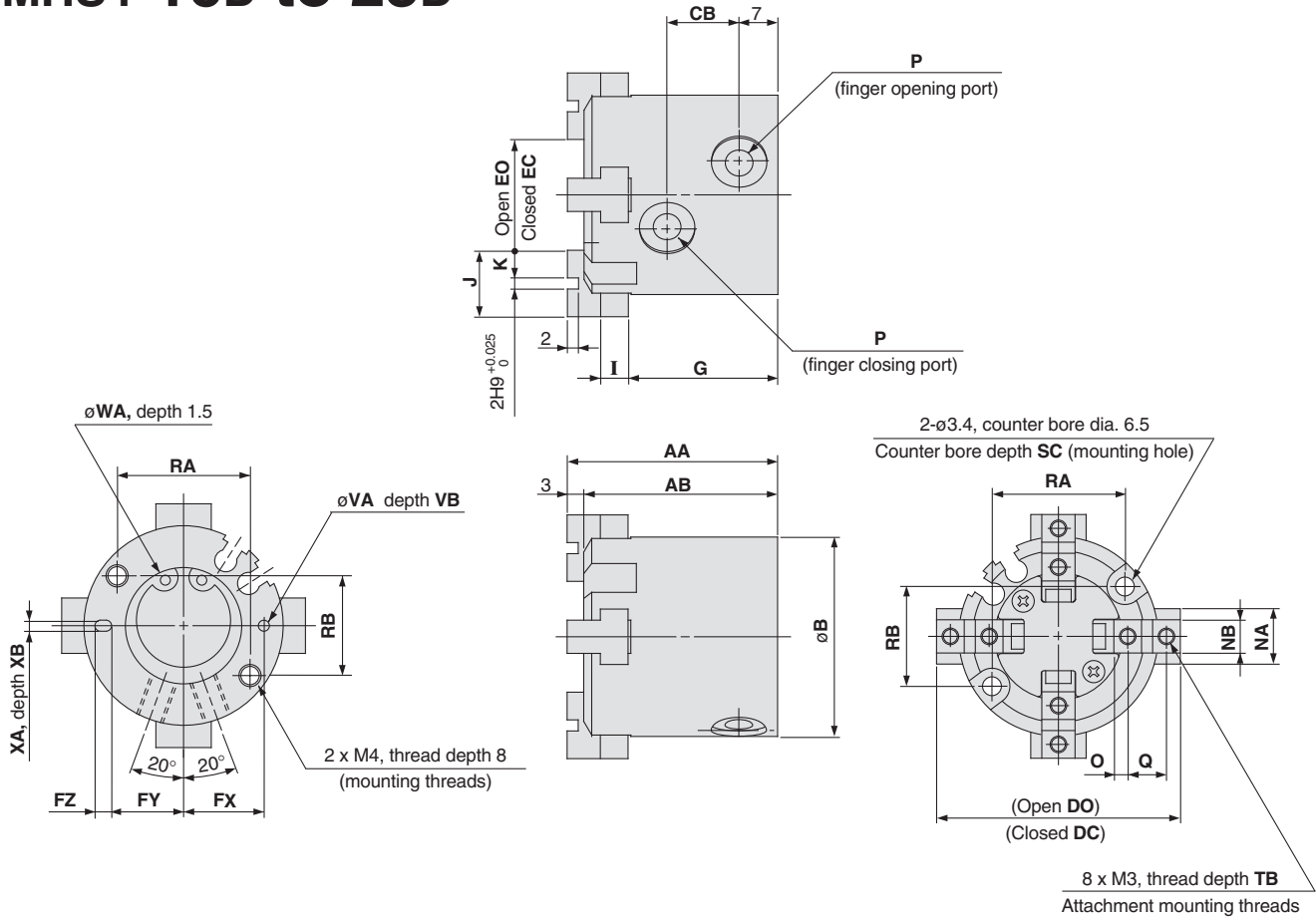

Auto switch mounting groove positions (2 locations)

MHS4-16D

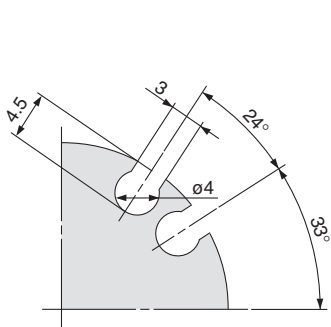

MHS4-20D

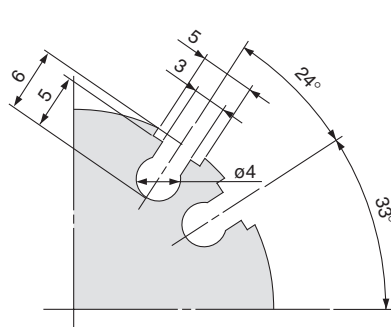

MHS4-25D

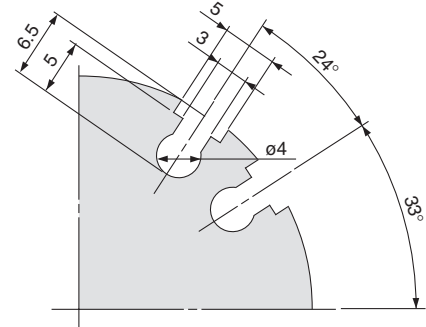

Model	AA	AB	B	CB	DC	DO	EC	EO	FX	FY	FZ	G	I	J	K	NA	NB	O	P	Q
MHS4-16D	35	32	30	11	33	37	13	17	12.5	11	3	25	4	10	4	8	5h9 ₀ ⁰ _{-0.030}	2	M3	6
MHS4-20D	38	35	36	13	39	43	15	19	14.5	13	3	27	5	12	5	10	6h9 ₀ ⁰ _{-0.030}	2.5	M5	7
MHS4-25D	40	37	42	15	48	54	20	26	17	14.5	5	28	5	14	6	12	6h9 ₀ ⁰ _{-0.030}	3	M5	8

Model	RA	RB	SC	TB	VA	VB	WA	XA	XB
MHS4-16D	18	16	8	5	2H9 ₀ ^{+0.025}	2	17H9 ₀ ^{+0.043}	2H9 ₀ ^{+0.025}	2
MHS4-20D	24	18	9.5	6	2H9 ₀ ^{+0.025}	2	21H9 ₀ ^{+0.052}	2H9 ₀ ^{+0.025}	2
MHS4-25D	26	22	10	6	3H9 ₀ ^{+0.025}	3	26H9 ₀ ^{+0.052}	3H9 ₀ ^{+0.025}	3

Series MHS4

Dimensions

MHS4-32D, 40D

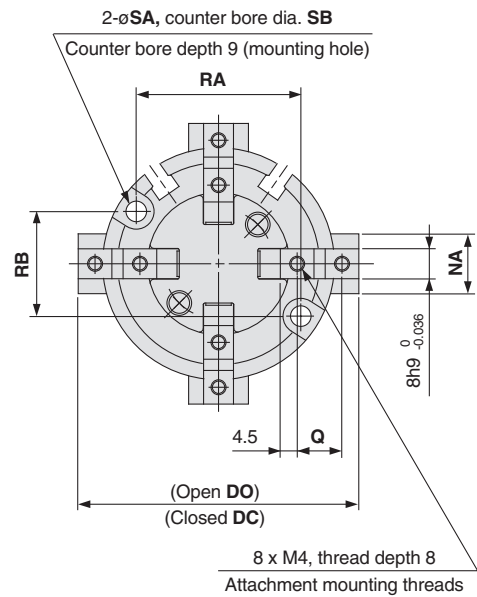
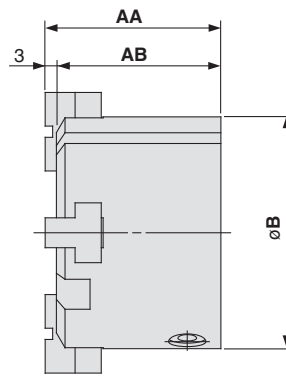
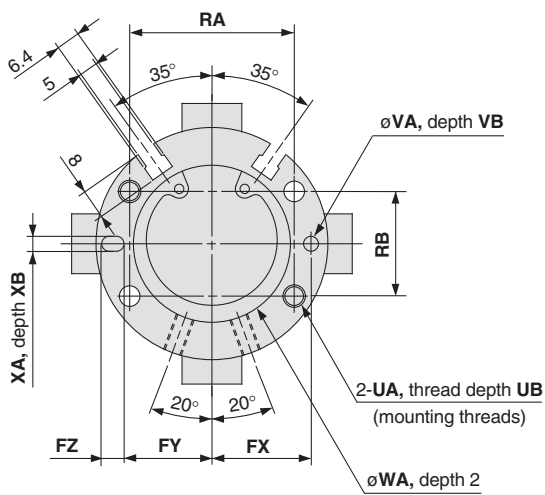
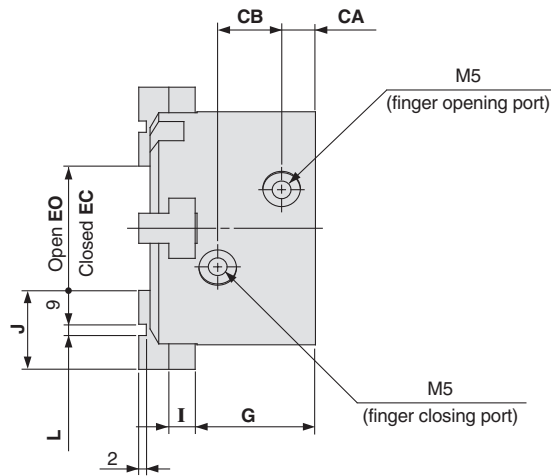

Model	AA	AB	B	CA	CB	DC	DO	EC	EO	FX	FY	FZ	G	I	J	L	NA	Q	RA	RB	SA
MHS4-32D	44	41	56	8	16	60	68	20	28	23	20.5	5	30.5	6	20	2H9 ^{+0.025} ₀	14	11	38	25	4.5
MHS4-40D	47	44	62	9	17	66	74	24	32	26.5	23.5	6	32	7	21	3H9 ^{+0.025} ₀	16	12	44	28	5.5





Model	SB	UA	UB	VA	VB	WA	XA	XB
MHS4-32D	8	M5	10	3H9 ^{+0.025} ₀	3	34H9 ^{+0.062} ₀	3H9 ^{+0.025} ₀	3
MHS4-40D	9.5	M6	12	4H9 ^{+0.030} ₀	4	42H9 ^{+0.062} ₀	4H9 ^{+0.030} ₀	4

Series MHS

Auto Switch Installation Examples and Mounting Positions

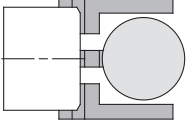
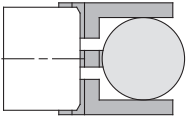
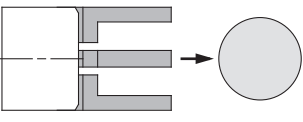
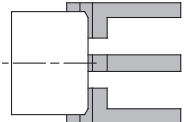
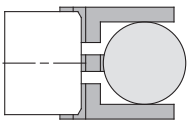
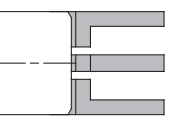
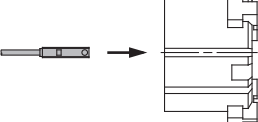
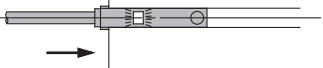
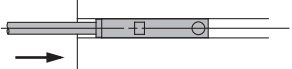
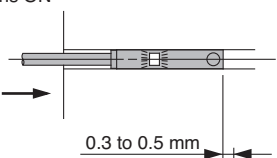
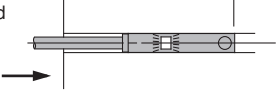
Various auto switch applications are possible through different combinations of auto switch quantities and detecting positions.

1) Detection when Gripping Exterior of Workpiece



Detection example		1. Confirmation of fingers in reset position	2. Confirmation of workpiece held	3. Confirmation of workpiece released
Position to be detected		Position of fingers fully opened 	Position when gripping a workpiece 	Position of fingers fully closed 
Operation of auto switch		Auto switch turned ON when fingers return. (Light ON)	Auto switch turned ON when gripping a workpiece. (Light ON)	When a workpiece is not held (Abnormal operation): Auto switch to turn ON (Light ON)
Detection combinations	One auto switch * One position, any of ①, ② and ③ can be detected.	●	●	●
	Two auto switches * Two positions of ①, ② and ③ can be detected.	Pattern A	●	—
		Pattern B	—	●
Pattern C	●	—	●	
How to determine auto switch installation position		Step 1) Fully open the fingers. 	Step 1) Position fingers for gripping a workpiece. 	Step 1) Fully close the fingers. 
At no pressure or low pressure, connect the auto switch to a power supply, and follow the directions.		Step 2) Insert the auto switch into the auto switch installation groove in the direction shown in the following drawing. 		
		Step 3) Slide the auto switch in the direction of the arrow until the indicator light illuminates. 	Step 3) Slide the auto switch in the direction of the arrow until the indicator light illuminates. Move the switch further 0.3 to 0.5 mm in the direction of the arrow and fasten it.	
		Step 4) Slide the auto switch in the direction of the arrow until the indicator light goes out. 	Position where light turns ON  0.3 to 0.5 mm Position to be secured 	
		Step 5) Move the auto switch in the opposite direction until the indicator light illuminates. Move the switch further 0.3 to 0.5 mm beyond the position where the indicator light illuminates and fasten it. 		
		Position where light turns ON  0.3 to 0.5 mm Position to be secured 		

Note 1) It is recommended that gripping of a workpiece be performed close to the center of the finger stroke.

Note 2) When holding a workpiece close at the end of open/close stroke of fingers, detecting performance of the combinations listed in the above table may be limited, depending on the hysteresis of an auto switch, etc.

Various auto switch applications are possible through different combinations of auto switch quantities and detecting positions.

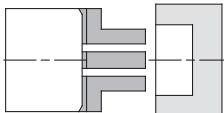
2) Detection when Gripping Interior of Workpiece

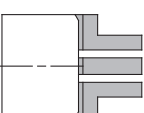
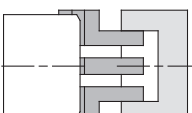
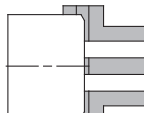
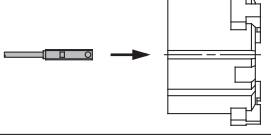
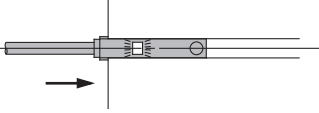
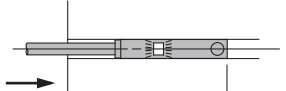
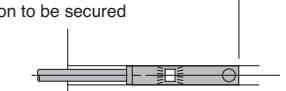
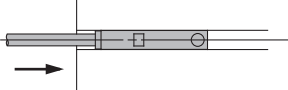
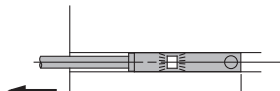
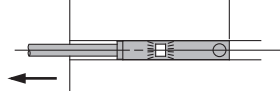
Detection example		1. Confirmation of fingers in reset position	2. Confirmation of workpiece held	3. Confirmation of workpiece released
Position to be detected	Position of fingers fully closed		Position when gripping a workpiece	Position of fingers fully opened 
Operation of auto switch	Auto switch turned ON when fingers return. (Light ON)		Auto switch turned ON when gripping a workpiece. (Light ON)	When a workpiece is not held (Abnormal operation): Auto switch to turn ON (Light ON)
Detection combinations	One auto switch <small>* One position, any of ①, ② and ③ can be detected.</small>	●	●	●
	Two auto switches <small>* Two positions of ①, ② and ③ can be detected.</small>	●	●	—
		—	●	●
Pattern	A	●	●	—
B	—	—	●	●
C	●	—	—	●
How to determine auto switch installation position	Step 1) Fully close the fingers. 	Step 1) Position fingers for gripping a workpiece. 	Step 1) Fully open the fingers. 	
At no pressure or low pressure, connect the auto switch to a power supply, and follow the directions.	Step 2) Insert the auto switch into the auto switch installation groove in the direction shown in the following drawing. 		Also, in case of lead wire entry from the finger direction, installation should be from the direction shown in the drawing.	
	Step 3) Slide the auto switch in the direction of the arrow until the indicator light illuminates. Move the switch further 0.3 to 0.5 mm in the direction of the arrow and fasten it.	Step 3) Slide the auto switch in the direction of the arrow until the indicator light illuminates. 		
	Position where light turns ON  0.3 to 0.5 mm Position to be secured 	Step 4) Slide the auto switch further in the direction of the arrow until the indicator light goes out.  Step 5) Move an auto switch in the opposite direction and fasten it at a position 0.3 to 0.5 mm beyond the position where the indicator light illuminates. Position where light turns ON  0.3 to 0.5 mm Position to be secured 		

Note 1) It is recommended that gripping of a workpiece be performed close to the center of the finger stroke.

Note 2) When holding a workpiece close at the end of open/close stroke of fingers, detecting performance of the combinations listed in the above table may be limited, depending on the hysteresis of an auto switch, etc.

Series MHS

Auto Switch Hysteresis

Auto switches have hysteresis similar to micro switches. Use the table below as a guide when adjusting auto switch positions, etc.

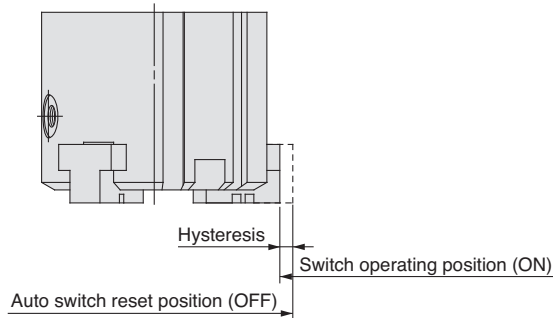

Series MHS□/MHSL

Air gripper model	Auto switch model	Hysteresis (Max. value) (mm)	
		D-M9□(V) D-M9□W(V) D-M9□A(V)	
MHS□ - 16D MHSL3		0.5	
MHS□ - 20D MHSL3		0.5	
MHS□ - 25D MHSL3		0.5	
MHS□ - 32D MHSL3		0.6	
MHS□ - 40D MHSL3		0.6	
MHS□ - 50D MHSL3		0.6	
MHS□ - 63D MHSL3		0.6	
MHS□ - 80D MHSL3		0.6	
MHS□ - 100D MHSL3		0.6	
MHS□ - 125D MHSL3		0.6	

Air gripper model	Auto switch model	Hysteresis (Max. value) (mm)	
		D-Y59□/Y69□/Y7P(V) D-Y7□W(V)/Y7BA	
MHS□ - 32D MHSL3		0.7	
MHS□ - 40D MHSL3		0.5	
MHS□ - 50D MHSL3		0.5	
MHS□ - 63D MHSL3		0.5	
MHS□ - 80D MHSL3		0.5	
MHS□ - 100D MHSL3		0.5	
MHS□ - 125D MHSL3		0.5	

Note) The actual mounting position should be adjusted after confirming the auto switch performance.

Series MHSJ/MHSH

Air gripper model	Auto switch model	Hysteresis (Max. value) (mm)	
		D-M9□(V) D-M9□W(V) D-M9□A(V)	
MHSJ3 -16D MHSH3		0.5	
MHSJ3 -20D MHSH3		0.5	
MHSJ3 -25D MHSH3		0.5	
MHSJ3 -32D MHSH3		0.6	
MHSJ3 -40D MHSH3		0.6	
MHSJ3 -50D MHSH3		0.6	
MHSJ3 -63D MHSH3		0.6	
MHSJ3 -80D MHSH3		0.6	

Auto Switch Hysteresis

Center pusher/Cylinder type

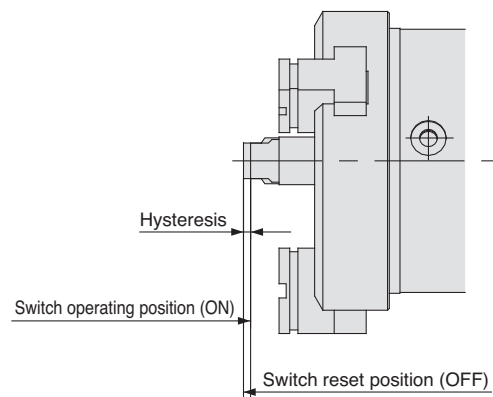

Air gripper model	Auto switch model	Hysteresis (Max. value) (mm)	
		D-M9□(V) D-M9□W(V) D-M9□A(V)	
MHSH□3-32DA		0.3	
MHSH□3-40DA		0.3	
MHSH□3-50DA		0.2	
MHSH□3-63DA		0.4	
MHSH□3-80DA		0.3	

Note) The actual mounting position should be adjusted after confirming the auto switch performance.

Protrusion of Auto Switch from Edge of Body

The projection of an auto switch from the edge of the body is shown in the table below. Use the table as a guideline for mounting.

(mm)

Direction of auto switch mounting on air gripper		Mounting with lead wire on side opposite the fingers				Mounting with lead wire on same side as the fingers			
		In-line entry		Perpendicular entry		In-line entry		Perpendicular entry	
		D-M9□ D-M9□W	D-M9□A	D-M9□V D-M9□WV	D-M9□AV	D-M9□ D-M9□W	D-M9□A	D-M9□V D-M9□WV	D-M9□AV
Auto switch model	Open	—	1	—	—	1	3	—	1
	Closed	5	7	3	5	—	—	—	—
Auto switch model	Open	—	—	—	—	—	—	—	—
	Closed	5	7	3	5	—	—	—	—
Auto switch model	Open	—	—	—	—	—	1	—	—
	Closed	3	5	1	3	—	—	—	—
Auto switch model	Open	—	1	—	—	—	—	—	—
	Closed	5	7	3	5	—	—	—	—
Auto switch model	Open	—	—	—	—	—	—	—	—
	Closed	5	7	3	5	—	—	—	—
Auto switch model	Open	—	—	—	—	—	—	—	—
	Closed	3	5	1	3	—	—	—	—
Auto switch model	Open	—	—	—	—	—	—	—	—
	Closed	5.5	7.5	3.5	5.5	—	—	—	—
Auto switch model	Open	—	—	—	—	—	—	—	—
	Closed	5	7	3.5	5	—	—	—	—
Auto switch model	Open	—	—	—	—	—	—	—	—
	Closed	4.5	6.5	2.5	4.5	—	—	—	—
Auto switch model	Open	—	—	—	—	—	—	—	—
	Closed	2.5	4.5	0.5	2.5	—	—	—	—
Auto switch model	Open	—	—	—	—	—	—	—	—
	Closed	—	—	—	—	—	—	—	—
Auto switch model	Open	—	—	—	—	—	—	—	—
	Closed	—	—	—	—	—	—	—	—
Auto switch model	Open	—	—	—	—	—	—	—	—
	Closed	—	—	—	—	—	—	—	—
Auto switch model	Open	—	—	—	—	—	—	—	—
	Closed	—	—	—	—	—	—	—	—
Auto switch model	Open	—	—	—	—	—	—	—	—
	Closed	—	—	—	—	—	—	—	—
Auto switch model	Open	—	—	—	—	—	—	—	—
	Closed	—	—	—	—	—	—	—	—
Auto switch model	Open	—	—	—	—	—	—	—	—
	Closed	—	—	—	—	—	—	—	—

Note 1) There is no protrusion for sections of the table with no values entered.

Note 2) When mounted with lead wires on the finger side, be sure that attachments and workpieces, etc., do not touch switch units or lead wires.

Note 3) The actual mounting position should be adjusted after confirming the auto switch performance.

Series MHS

Protrusion of Auto Switch from Edge of Body

The projection of an auto switch from the edge of the body is shown in the table below.
Use the table as a guideline for mounting.

(mm)

Direction of auto switch mounting on air gripper		Mounting with lead wire on side opposite the fingers			Mounting with lead wire on same side as the fingers		
		In-line entry		Perpendicular entry	In-line entry		Perpendicular entry
Air gripper model	Lead wire type	D-Y59□ D-Y7P D-Y7□W	D-Y7BA	D-Y69□ D-Y7PV D-Y7□WV	D-Y59□ D-Y7P D-Y7□W	D-Y7BA	D-Y69□ D-Y7PV D-Y7□WV
	MHS□-32D	Open	—	—	—	—	5
Closed		6	9	4	—	—	—
MHS□-40D	Open	—	—	—	—	2.5	—
	Closed	5.5	8	4	—	—	—
MHS□-50D	Open	—	—	—	—	—	—
	Closed	5	7.5	3	—	—	—
MHS□-63D	Open	—	—	—	—	—	—
	Closed	3	5	1	—	—	—
MHS□-80D	Open	—	—	—	—	—	—
	Closed	—	—	—	—	—	—
MHS□-100D	Open	—	—	—	—	—	—
	Closed	—	—	—	—	—	—
MHS□-125D	Open	—	—	—	—	—	—
	Closed	—	—	—	—	—	—
MHSL3-32D	Open	—	—	—	—	—	—
	Closed	6	9	4	—	—	—
MHSL3-40D	Open	—	—	—	—	—	—
	Closed	5.5	8	4	—	—	—
MHSL3-50D	Open	—	—	—	—	—	—
	Closed	5	7.5	3	—	—	—
MHSL3-63D	Open	—	—	—	—	—	—
	Closed	3	5	1	—	—	—
MHSL3-80D	Open	—	—	—	—	—	—
	Closed	—	—	—	—	—	—
MHSL3-100D	Open	—	—	—	—	—	—
	Closed	—	—	—	—	—	—
MHSL3-125D	Open	—	—	—	—	—	—
	Closed	—	—	—	—	—	—

Note 1) There is no protrusion for sections of the table with no values entered.

Note 2) When mounted with lead wires on the finger side, be sure that attachments and workpieces, etc., do not touch switch units or lead wires.

Note 3) The actual mounting position should be adjusted after confirming the auto switch performance.

Protrusion of Auto Switch from Edge of Body

The projection of an auto switch from the edge of the body is shown in the table below. Use the table as a guideline for mounting.

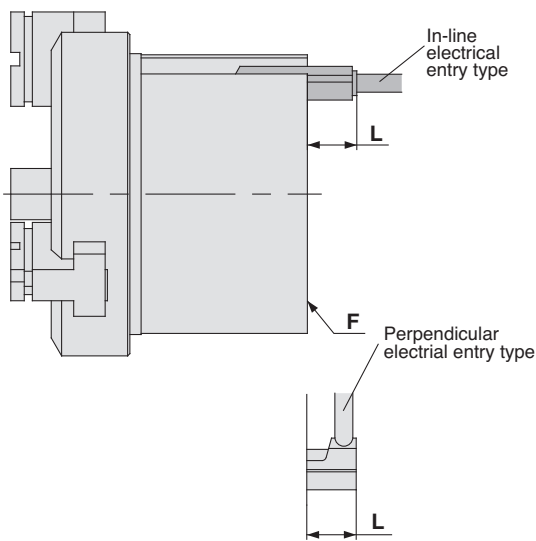

Auto switch model Finger position		Lead wire type			
		In-line entry		Perpendicular entry	
Air gripper model		D-M9□ D-M9□W	D-M9□A	D-M9□V D-M9□WV	D-M9□AV
MHSJ3 MHS3	Open	2	4	—	2
	Closed	5.5	7.5	3.5	5.5
MHSJ3 MHS3	Open	2	4	—	2
	Closed	5	7	3	5
MHSJ3 MHS3	Open	—	3	—	—
	Closed	5	7	3	5
MHSJ3 MHS3	Open	—	1	—	—
	Closed	4.5	6.5	2.5	4.5
MHSJ3 MHS3	Open	—	—	—	—
	Closed	3	5	1	3
MHSJ3 MHS3	Open	—	—	—	—
	Closed	1.5	3.5	—	1.5
MHSJ3 MHS3	Open	—	—	—	—
	Closed	—	2	—	—
MHSJ3 MHS3	Open	—	—	—	—
	Closed	—	1	—	—

- Note 1) Indicates the amount of protrusion from the mounting surface F. There is no protrusion from the finger side.
- Note 2) There is no protrusion for sections of the table with no values entered.
- Note 3) When mounted with lead wires on the finger side, be sure that attachments and workpieces, etc., do not touch switch units or lead wires.
- Note 4) The actual mounting position should be adjusted after confirming the auto switch performance.

Protrusion from Edge of Push Holder (P)

The amount of auto switch protrusion from the push holder (P) end surface is shown in the table below. Use this as a standard when mounting, etc.

Center Pusher/Cylinder Type

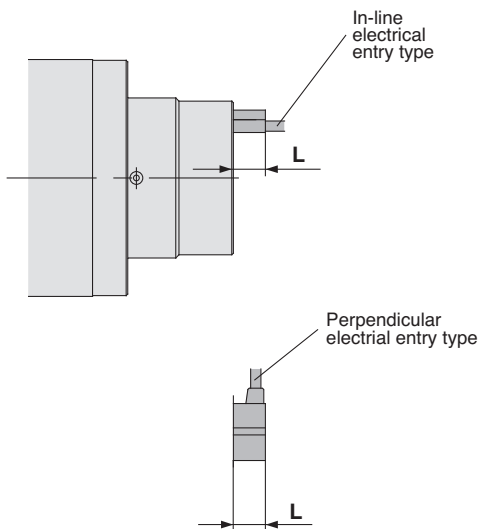

Auto switch model Finger position		Lead wire type			
		In-line entry		Perpendicular entry	
Air gripper model		D-M9□ D-M9□W	D-M9□A	D-M9□V D-M9□WV	D-M9□AV
MHS□-32DA	Extended	4	2	2	4
	Retracted	9	7	7	9
MHS□-40DA	Extended	3	—	1	3
	Retracted	8	6	6	8
MHS□-50DA	Extended	—	—	—	—
	Retracted	7.5	5.5	5.5	7.5
MHS□-63DA	Extended	—	—	—	—
	Retracted	7	5	5	7
MHS□-80DA	Extended	—	—	—	—
	Retracted	4	2	2	4

Note) The actual mounting position should be adjusted after confirming the auto switch performance.

Series MHS

Auto Switch Mounting

Applicable models:

MHS2-16, 20, 25
 MHS3-16, 20, 25
 MHSJ3-16, 20, 25, 32, 40, 50, 63, 80
 MSH3-16, 20, 25, 32, 40, 50, 63, 80
 MSH3-A32, 40, 50, 63, 80
 MHSL3-16, 20, 25
 MHS4-16, 20, 25

To set the auto switch, insert the auto switch into the installation groove of the gripper from the direction indicated in the following drawing. After setting the position, tighten the attached auto switch mounting set screw with a flat head watchmaker's screwdriver.

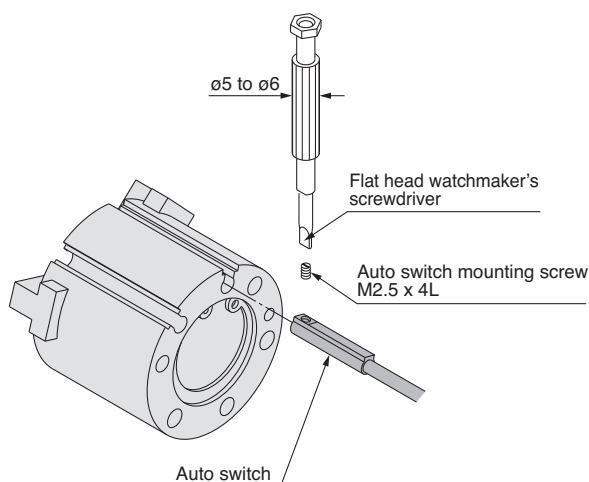

Note) Use a watchmaker's screwdriver with a grip diameter of 5 to 6 mm to tighten the auto switch mounting screw. The tightening torque should be about 0.05 to 0.15 N·m.

Applicable models:

MHS2-32, 40, 50, 63
 MHS3-32, 40, 50, 63, 80, 100, 125
 MHSL3-32, 40, 50, 63, 80, 100, 125
 MHS4-32, 40, 50, 63

- (1) To set the auto switch, insert the auto switch into the installation groove of the cylinder as shown below and set it roughly.
- (2) Insert the auto switch into the auto switch bracket installation groove.
- (3) After confirming the detecting position, tighten the set screws (M2.5) attached to the auto switch and set it.
- (4) Be sure to change the detecting position in the state of (2).

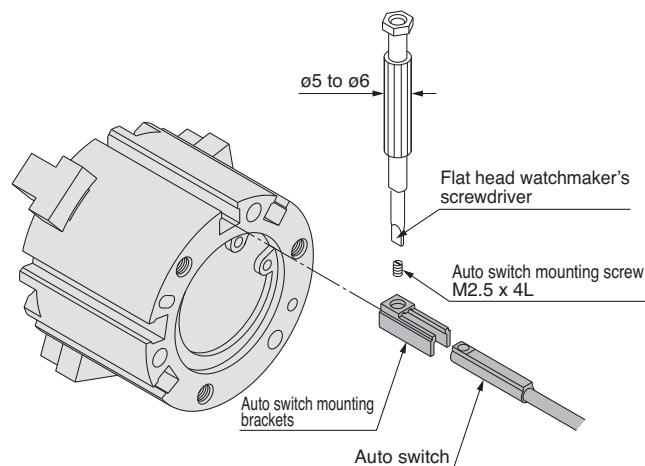

Auto Switch Mounting Bracket Part No.

Auto switch model	Auto switch mounting bracket part no.
D-M9□(V)	BMG2-012
D-M9□W(V)	
D-M9□A(V)	

Note) Use a watchmaker's screwdriver with a grip diameter of 5 to 6 mm to tighten the set screw (M2.5). The tightening torque should be 0.05 to 1 N·m. It should be turned about 90° beyond the point at which tightening can be felt.

1 Oil Resistant Specifications

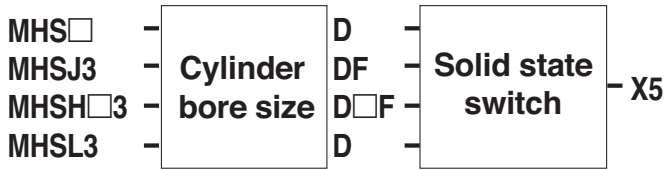

Seals are changed to an oil resistant material for use in environments where there is exposure to cutting oil, etc.

Specifications

Type		Oil resistant type	
Cylinder bore size mm	16, 20, 25	32, 40, 50, 63, 80, 100, 125	
Action	Double acting		
Fluid	Air		
Material	Seals, gaskets — Fluoro rubber		
Applicable auto switches	MHS MHSL	D-M9BAL	D-Y7BAL
	MHSJ	D-M9BAL	
	MHSH		

Note 1) Depending on the type of cutting oil, there are cases in which it is not possible to use air grippers and auto switches. After confirming the type of cutting oil, contact SMC regarding any questions on this matter.

Note 2) Dimensions are the same as the standard type.

2 Heat Resistant Specifications

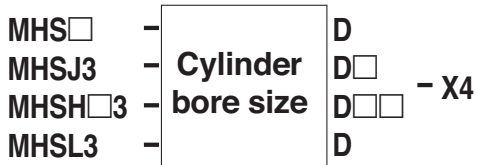

Seals and grease are changed to heat resistant materials for use in high temperature ambient conditions up to 100C.

Specifications

Type		Heat resistant type	
Cylinder bore size mm	16, 20, 25, 32, 40, 50, 63, 80, 100, 125		
Action	Double acting		
Fluid	Air		
Material	Seals, gaskets — Fluoro rubber		

Note 1) Not available with auto switches.

Note 2) Dimensions are the same as the standard type.

Note 3) Select fluoro rubber (F) or silicon rubber (Si) for the dust cover material.



Series MHS Air Gripper Precautions 1

Be sure to read before handling.

Mounting

Warning Attachment design

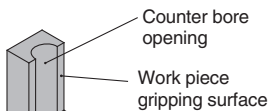
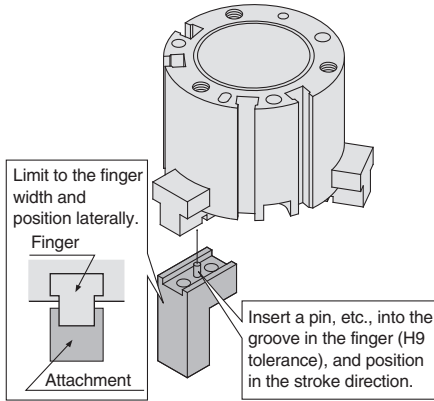

In cases of small diameter work pieces, etc., where there is interference between the work piece gripping surface and the bolt position, provide a counter bore in the work piece gripping surface to accommodate the head of the bolt, as shown in the drawing to the left.

3. Fasten the push plate and other parts securely to the push rod at a torque within the limiting range.

Insufficient tightening can cause slippage or dropping, etc.

Mounting of push plate, etc., onto push rod

Mount a push plate or other parts to the female mounting threads of the push rod using a bolt, etc., and tighten at the appropriate torque shown in the table below.

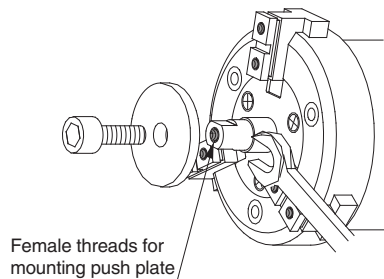

Series MSH3 (with centre pusher)

Model	Bolt	Maximum torque N·m	Max. screw depth mm
MHS□3-32DA, B	M3	0.6	6
-40DA, B	M5	2.8	10
-50DA, B	M6	4.8	12
-63DA, B	M8	12	16
-80DA, B	M10	24	20

4. When installing or removing the product's dust cover, use the procedure shown in the drawing below.

Installation and removal of dust cover

<Removal>

1. Squeeze the sections of the dust cover and remove the dust cover return from the circumference of the guide.
2. When the dust cover return has been removed from the circumference of the guide, pull it in the direction of the arrows while holding the sections and remove it from the slots in the fingers.
3. When the dust cover is removed from the slots in the fingers, pull it in the direction of the arrows and remove it from the product.

<Mounting>

1. Reversing the removal procedure, install the dust cover in the slots in the fingers.
2. Install the dust cover return onto the entire circumference of the guide.
Note) Be careful not to tear the dust cover when installing or removing it.

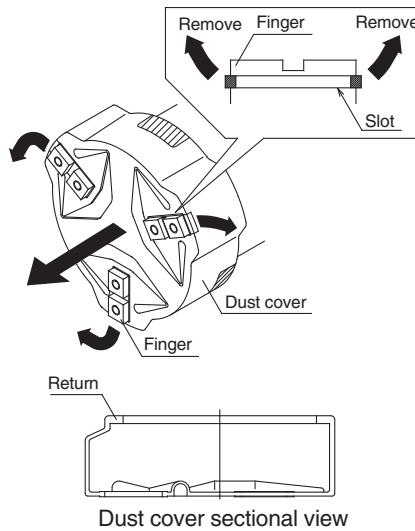

5. When mounting an air gripper, tighten screws properly at a torque value within the limits of the specified range.

Tightening at a torque above the limits of the range can cause malfunction, while tightening at a lower torque can cause slipping or dropping of work pieces, etc.

Mounting of air gripper

Using tapped holes

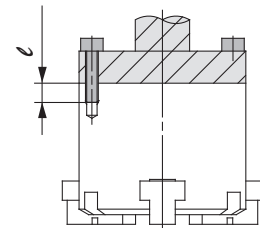

Series MHS2

Model	Bolt	Maximum torque N·m	Max. screw depth ℓ (mm)
MHS2- 16D	M4	2.1	8
20D	M4	2.1	8
25D	M4	2.1	8
32D	M5	4.3	10
40D	M6	7.3	12
50D	M6	7.3	12
63D	M6	7.3	12

Series MHS3, MHSL3

Model	Bolt	Maximum torque N·m	Max. screw depth ℓ (mm)
MHS3- 16D	M3	0.88	6
MHSL3- 20D	M3	0.88	6
25D	M4	1.6	6
32D	M4	1.6	6
40D	M5	4.3	10
50D	M5	4.3	10
63D	M6	7.3	12
80D	M6	7.3	12
100D	M8	18	16
125D	M10	36	20

Series MHS4

Model	Bolt	Maximum torque N·m	Max. screw depth ℓ (mm)
MHS4- 16D	M4	2.1	8
20D	M4	2.1	8
25D	M4	2.1	8
32D	M5	4.3	10
40D	M6	7.3	12
50D	M6	7.3	12
63D	M6	7.3	12



Series MHS Air Gripper Precautions 2

Be sure to read before handling.

Mounting

Mounting of air gripper

Using tapped holes

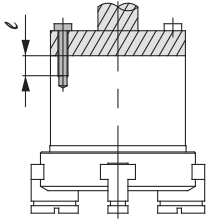

Series MHSJ3, MSH3

Model	Bolt	Max. torque N·m	Max. screw depth ℓ (mm)
MHSJ3-16D MSH3	M4	2.1	8
MHSJ3-20D MSH3	M4	2.1	8
MHSJ3-25D MSH3	M4	2.1	8
MHSJ3-32D MSH3	M4 M5	2.1 3.2	8 10
MHSJ3-40D MSH3	M4 M5	2.1 3.2	8 10
MHSJ3-50D MSH3	M5 M6	3.2 7.3	10 12
MHSJ3-63D MSH3	M6 M8	7.3 18	12 16
MHSJ3-80D MSH3	M6 M8	7.3 18	12 16

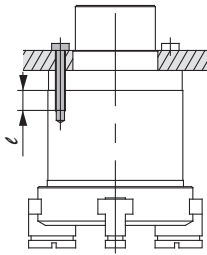

Series MSH3 (center pusher)

Model	Bolt	Max. torque N·m	Max. screw depth ℓ (mm)
MHS3-32DA MHS3-32DB	M5	3.2	10
MHS3-40DA MHS3-40DB	M5	3.2	10
MHS3-50DA MHS3-50DB	M6	7.3	12
MHS3-63DA MHS3-63DB	M8	18	16
MHS3-80DA MHS3-80DB	M8	18	16

Using through holes

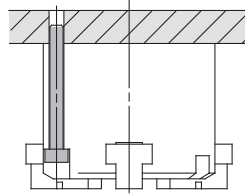

Series MHS2

Model	Bolt	Maximum torque N·m
MHS2-16D	M3	0.88
20D	M3	0.88
25D	M3	0.88
32D	M4	2.1
40D	M5	4.3
50D	M5	4.3
63D	M5	4.3

Series MHS3, MHSL3

Model	Bolt	Maximum torque N·m
MHS3-16D	M3	0.88
MHSL3-20D	M3	0.88
25D	M4	2.1
32D	M4	2.1
40D	M5	4.3
50D	M5	4.3
63D	M6	7.3
80D	M6	7.3
100D	M8	18
125D	M10	36

Series MHS4

Model	Bolt	Maximum torque N·m
MHS4-16D	M3	0.88
20D	M3	0.88
25D	M3	0.88
32D	M4	2.1
40D	M5	4.3
50D	M5	4.3
63D	M5	4.3

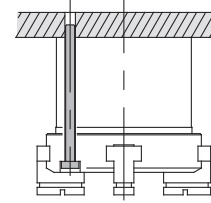

Series MHSJ3, MSH3

Model	Bolt	Maximum torque N·m
MHSJ3-16D MSH3	M3	0.88
MHSJ3-20D MSH3	M3	0.88
MHSJ3-25D MSH3	M3	0.88
MHSJ3-32D MSH3	M4	2.1
MHSJ3-40D MSH3	M4	2.1
MHSJ3-50D MSH3	M5	4.3
MHSJ3-63D MSH3	M6	7.3
MHSJ3-80D MSH3	M6	7.3

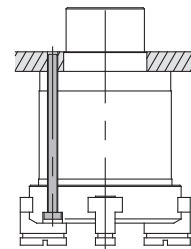

Series MSH3 (center pusher)

Model	Bolt	Maximum torque N·m
MHS3-32DA MHS3-32DB	M4	2.1
MHS3-40DA MHS3-40DB	M4	2.1
MHS3-50DA MHS3-50DB	M5	4.3
MHS3-63DA MHS3-63DB	M6	7.3
MHS3-80DA MHS3-80DB	M6	7.3

Note) When using the through holes to mount models MHSJ3 and MSHJ3, first remove the dust cover from the product, and after screwing it into place, reinstall the dust cover. Refer to page 5-216 for installation and removal of the dust cover.

