

Pressure relief valve, pilot-operated

Type DB...W65; DBW...W65; DB 20 K

RE 25818

Edition: 2017-06

Replaces: 2012-07



H6964

- ▶ Sizes 10 and 25
- ▶ Component series 1X; 4X
- ▶ Maximum operating pressure 350 bar
- ▶ Maximum flow 400 l/min

Features

- ▶ For subplate mounting
Porting pattern according to ISO 6264-06-09-* -97 (NG10) and ISO 6264-08-13-* -97 (NG25)
- ▶ For threaded connection
- ▶ As screw-in cartridge valve
- ▶ 4 adjustment types for pressure adjustment, optionally:
 - Rotary knob
 - Bushing with hexagon and protective cap
 - Lockable rotary knob with scale
 - Rotary knob with scale
- ▶ 5 pressure ratings
- ▶ Solenoid-actuated unloading via a built-on directional spool valve

Contents

| | |
|-----------------------------------------------------------------------------------------------------------------------------------------|-----------|
| Features | 1 |
| Ordering code | 2, 3 |
| Symbols | 4 |
| Function, section | 5 |
| Technical data | 6, 7 |
| Characteristic curves | 7 ... 9 |
| Dimensions | 10 ... 15 |
| Mounting cavity | 14, 15 |
| Dimensions | 16 |
| Mating connectors | 19 |
| General information, Further information | 19 |
| Type-examination tested safety valves type DB 20 K...E, component series 1X according to Pressure Equipment Directive 2014/68/EU | |
| Ordering code | 17 |
| Deviating technical data | 17 |
| Safety instructions | 18 |

Ordering code

| | | | | | | | | | | | | | | | | | | |
|----|----|----|----|----|----|----|----|----|----|----|----|----|----|----|----|----|----|----|
| 01 | 02 | 03 | 04 | 05 | 06 | 07 | 08 | 09 | 10 | 11 | 12 | 13 | 14 | 15 | 16 | 17 | 18 | 19 |
| DB | | | | | - | / | | | | | | | | | | | | * |

| | | |
|----|---------------------------------|-----------------|
| 01 | Pressure relief valve | DB |
| 02 | Without directional valve | no code |
| | With attached directional valve | W ¹⁾ |

| | | |
|----|----------------------------------|----|
| 03 | - Size 10 | |
| | Subplate mounting "-" | 10 |
| | Threaded connection "G" (G1 1/2) | 10 |
| | - Size 25 | |
| | Subplate mounting "-" | 20 |
| | Threaded connection "G" (G3/4) | 15 |
| | Threaded connection "G" (G1) | 20 |
| | Screw-in cartridge valve "K" | 20 |

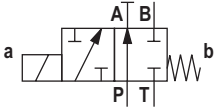
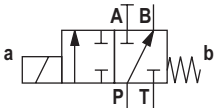
| | | | |
|----|------------------------------------------------------------------------------------|-----------------|-----------------|
| 04 |  | normally closed | A ²⁾ |
| |  | normally open | B ²⁾ |

Type of connection

| | | |
|----|--------------------------|---|
| 05 | Subplate mounting | - |
| | Threaded connection | G |
| | Screw-in cartridge valve | K |

Adjustment type

| | | |
|----|----------------------------------------------------------------------------------------------------------------------|-----------------|
| 06 | Rotary knob | 1 |
| | Bushing with hexagon and protective cap | 2 |
| | Lockable rotary knob with scale | 3 ³⁾ |
| | Rotary knob with scale | 7 |
| 07 | Component series 10 ... 19 (10 ... 19: unchanged installation and connection dimensions); (version "K" only) | 1X |
| | Component series 40 ... 49 (40 ... 49: unchanged installation and connection dimensions); (version "-" and "G" only) | 4X |

- 1) Only with version "G".
- 2) Ordering code only necessary with version "W".
- 3) H-key with material no. **R900008158** is included in the scope of delivery.
- 4) Dash "-" only necessary with version "W" and without specification of "U".
- 5) Mating connectors, separate order, see page 19.

Notices:

In case spare parts of the screw-in cartridge valve for standard subplate mounting or threaded connection housing NG10 and 25 are required, **always** order type DB 20 K.-1X/.XY. Type-examination tested safety valves are **only** available as type DB 20 K.-1X/.Y...E.

 **Notice:** Preferred types and standard units are contained in the EPS (standard price list).

Ordering code

| | | | | | | | | | | | | | | | | | | |
|----|----|----|----|----|----|----|----|----|----|----|----|----|----|----|----|----|----|----|
| 01 | 02 | 03 | 04 | 05 | 06 | 07 | 08 | 09 | 10 | 11 | 12 | 13 | 14 | 15 | 16 | 17 | 18 | 19 |
| DB | | | | | | - | / | | | | | | | | | | | * |

Pressure rating

| | | |
|----|------------------------------------------------|-----|
| 08 | Set pressure up to 50 bar | 50 |
| | Set pressure up to 100 bar | 100 |
| | Set pressure up to 200 bar | 200 |
| | Set pressure up to 315 bar | 315 |
| | Set pressure up to 350 bar (only version "DB") | 350 |

Pilot oil supply and pilot oil return (see also Symbols on page 4)

| | | |
|----|-----------------------------------------------------------------------|--------------------|
| 09 | Internal pilot oil supply and pilot oil return | - ⁴⁾ |
| | External pilot oil supply, internal pilot oil return | X |
| | Internal pilot oil supply, external pilot oil return | Y |
| | External pilot oil supply and pilot oil return | XY |
| 10 | Standard version | no code |
| | Valve for minimum cracking pressure (not suitable for mutual relief!) | U |
| 11 | Without directional valve | no code |
| | With directional spool valve (data sheet 23178) | 6E ²⁾ |
| 12 | Direct voltage 24 V | G24 ²⁾ |
| | AC voltage 230 V 50/60 Hz | W230 ²⁾ |
| 13 | With concealed manual override (standard) | N9 ²⁾ |
| | With manual override | N ²⁾ |
| | Without manual override | no code |

Corrosion resistance

| | | |
|----|--------------------------------------------------------------------------------------------------------|---------|
| 14 | None | no code |
| | High corrosion protection (720 h salt spray test according to EN ISO 9227); (only version "K" and "2") | J5 |

Electrical connection

| | | |
|----|-------------------------------------------------------|------------------|
| 15 | Individual connection | |
| | Without mating connector; connector DIN EN 175301-803 | K4 ²⁾ |

Seal material

| | | |
|----|-------------------------------------------------------------------------------------------------------|---------|
| 16 | NBR seals | no code |
| | FKM seals | V |
| | Observe compatibility of seals with hydraulic fluid used! (Other seals upon request) | |
| 17 | Vertical installation position of the screw-in cartridge valve (cartridge) (only version "-" and "G") | W65 |
| | Any installation position of the screw-in cartridge valve (only version "K") | no code |

Type-examination procedure

| | | |
|----|--------------------------------------------------------------------------------------|---------|
| 18 | Without type-examination procedure | no code |
| | Safety valve according to Pressure Equipment Directive 2014/68/EU (version "K" only) | E |
| 19 | Further details in the plain text | |

Symbols

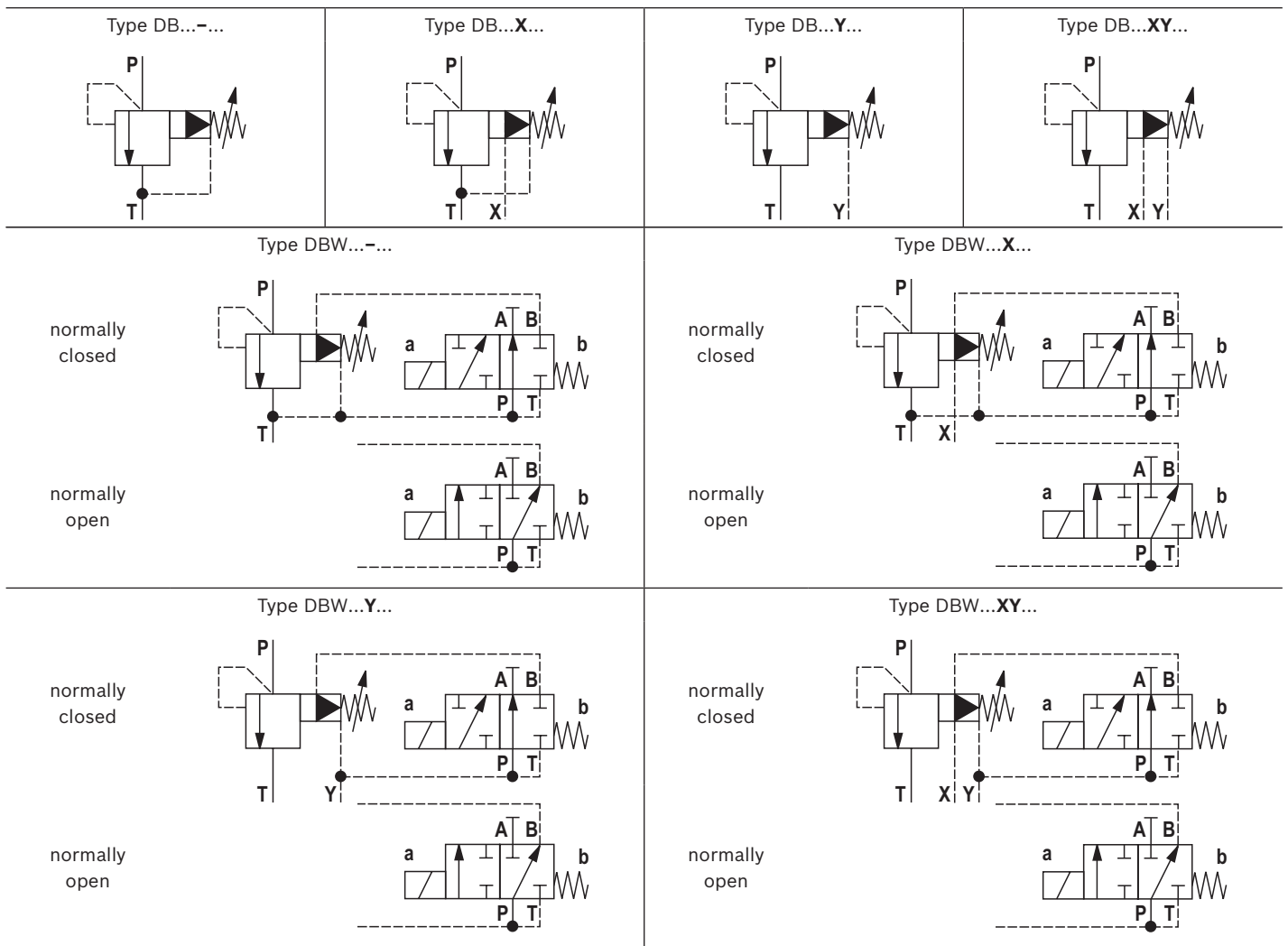

Function, section

Valves of type DB and DBW are pilot-operated pressure relief valves. They are used for limitation (DB) or limitation and solenoid-actuated unloading (DBW) of the operating pressure.

The valves basically consist of housing (1) and pilot control valve (2) with adjustment type.

Pressure relief valve type DB

The pressure applied to channel P acts on the main spool (3). Via the nozzle bores (4 and 5), the pressure is at the same time applied to poppet (6). If the pressure in channel P exceeds the value set at spring (7), poppet (6) opens against spring (7). Via the nozzle bores (4 and 5), the hydraulic fluid from channel P now flows into the spring chamber (8). From here, it is led into the tank internally (version "-"), via the control line (9 and 10), or externally (version "Y") via the control line (9 and 11).

Due to the state of equilibrium at the main spool (3), hydraulic fluid flows from channel P to channel T, maintaining the set operating pressure.

A pressure gauge connection (12) allows for the control of the operating pressure.

The pressure relief valve can be unloaded or switched to another pressure (second pressure rating) via port X (13).

Pressure relief valve type DBW (only threaded connection)

The function of this valve is basically the same as that of valve type DB.

The main spool (3) is unloaded by controlling a built-on directional valve.

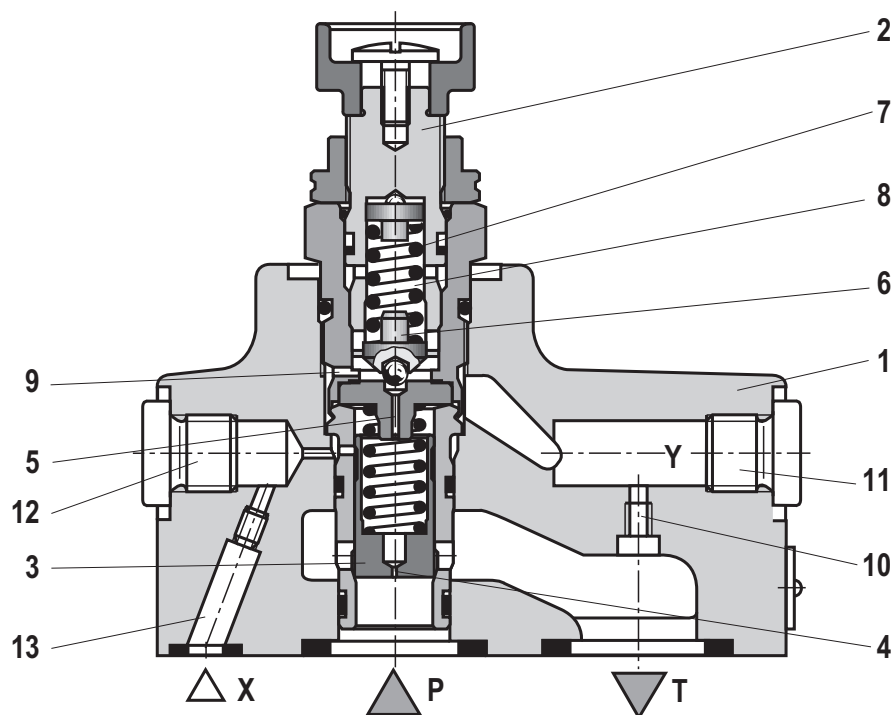

Technical data

(For applications outside these parameters, please consult us!)

| general | | | | |
|--------------------------------------------|--------------------------------|------------|------------------------------------------------------------------------------------------------------------------------------------------------------------------------------------------------------------------|------|
| Size | | | NG10 | NG25 |
| Weight | ▶ Subplate mounting "-" | kg | 1.6 | 2.3 |
| | ▶ Threaded connection "G" | - Type DB | kg | 2.95 |
| | | - Type DBW | kg | 4.25 |
| | ▶ Screw-in cartridge valve "K" | kg | - | 0.35 |
| Installation position | | | any | |
| Ambient temperature range | ▶ Type DB | °C | -30 ... +80 (NBR seals) -15 ... +80 (FKM seals) | |
| | ▶ Type DBW | | -30 ... +50 (NBR seals) -15 ... +50 (FKM seals) | |
| Minimum stability of the housing materials | | | Housing materials are to be selected so that there is sufficient safety for all imaginable operating conditions (e.g. with reference to pressure resistance, thread stripping strengths and tightening torques). | |

| hydraulic | | | | |
|----------------------------------------------------------------------------------------------------------------|---------------------------|--------------------|--------------------------------------------------------|----------------------|
| Maximum operating pressure | ▶ Port P, X | bar | 350 | |
| | ▶ Port T | bar | 315 | |
| Maximum counter pressure | ▶ Port Y - Type DB | bar | 250 | |
| | ▶ Port Y, T - Type DBW | bar | 210 (DC solenoid) 160 (AC solenoid) | |
| Minimum set pressure | | bar | flow-dependent, see characteristic curves page 8 ... 9 | |
| Maximum set pressure | | bar | 50; 100; 200; 315; 350 (only type DB) | |
| Maximum flow | ▶ Subplate mounting "-" | l/min | 200 | 400 |
| | ▶ Threaded connection "G" | | 150 | 200 (G3/4); 300 (G1) |
| Hydraulic fluid | | | see table page 7 | |
| Hydraulic fluid temperature range (at the valve working ports) | | °C | -20 ... +80 (NBR seals) -15 ... +80 (FKM seals) | |
| | | | | |
| Viscosity range | | mm ² /s | 10 ... 800 | |
| Maximum admissible degree of contamination of the hydraulic fluid, cleanliness class according to ISO 4406 (c) | | | Class 20/18/15 ¹⁾ | |

¹⁾ The cleanliness classes specified for the components must be adhered to in hydraulic systems. Effective filtration prevents faults and simultaneously increases the life cycle of the components.

For the selection of the filters see www.boschrexroth.com/filter.

Technical data for directional spool valve see data sheet 23178.

Technical data

(For applications outside these parameters, please consult us!)

| Hydraulic fluid | | Classification | Suitable sealing materials | Standards | Data sheet |
|-----------------|----------------------|----------------|----------------------------|-----------|------------|
| Mineral oils | | HL, HLP | NBR, FKM | DIN 51524 | 90220 |
| Bio-degradable | ▶ Insoluble in water | HETG | FKM | ISO 15380 | 90221 |
| | | HEES | FKM | | |
| | ▶ Soluble in water | HEPG | FKM | ISO 15380 | |

Important notices on hydraulic fluids:

- ▶ For further information and data on the use of other hydraulic fluids, please refer to the data sheets above or contact us.
- ▶ There may be limitations regarding the technical valve data (temperature, pressure range, life cycle, maintenance intervals, etc.).
- ▶ The ignition temperature of the hydraulic fluid used must be 50 K higher than the maximum surface temperature.

▶ **Bio-degradable:** If these hydraulic fluids are used, small amounts of dissolved zinc may get into the hydraulic system.

Characteristic curves

(measured with HLP46, $\vartheta_{oil} = 40 \pm 5^\circ\text{C}$)

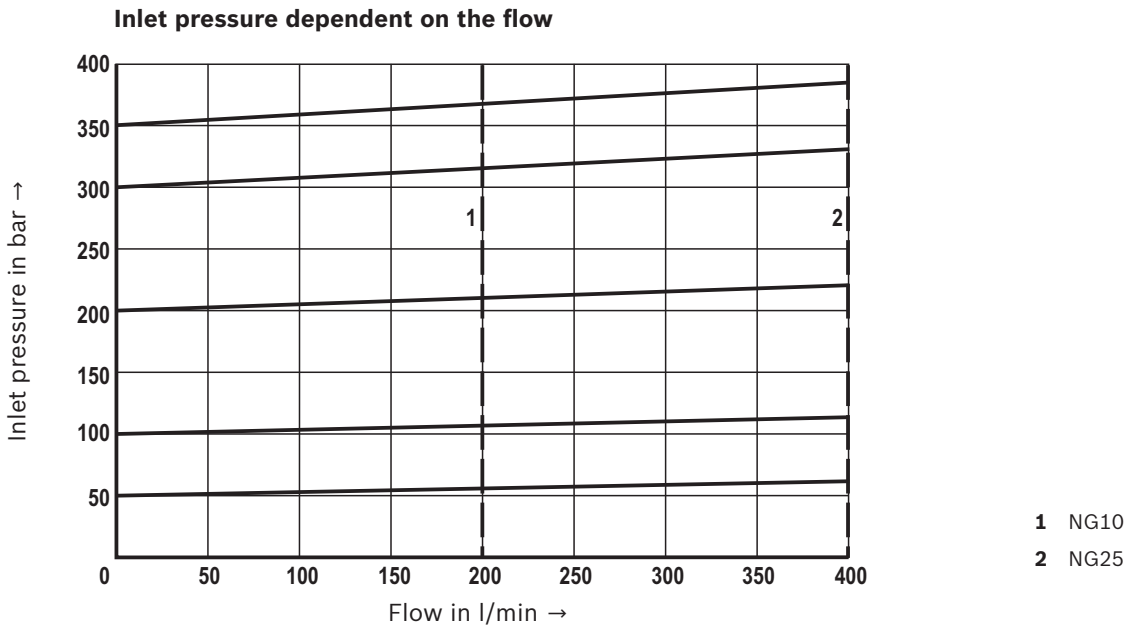

Notices:

The characteristic curves were measured with **external, depressurized pilot oil return**.
 With internal pilot oil return, the inlet pressure increases by the output pressure present in port T.

Characteristic curves: Subplate mounting
(measured with HLP46, $\vartheta_{oil} = 40 \pm 5 \text{ }^\circ\text{C}$)

Minimum set pressure and circulation pressure dependent on the flow ¹⁾
Standard version

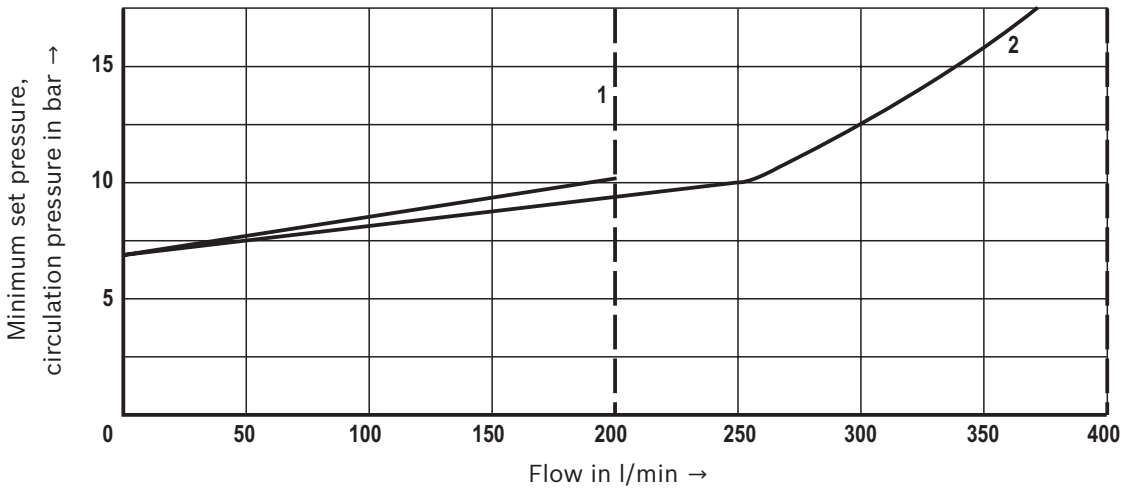

- 1 NG10
- 2 NG25

Minimum set pressure and circulation pressure dependent on the flow ¹⁾
Version "U"

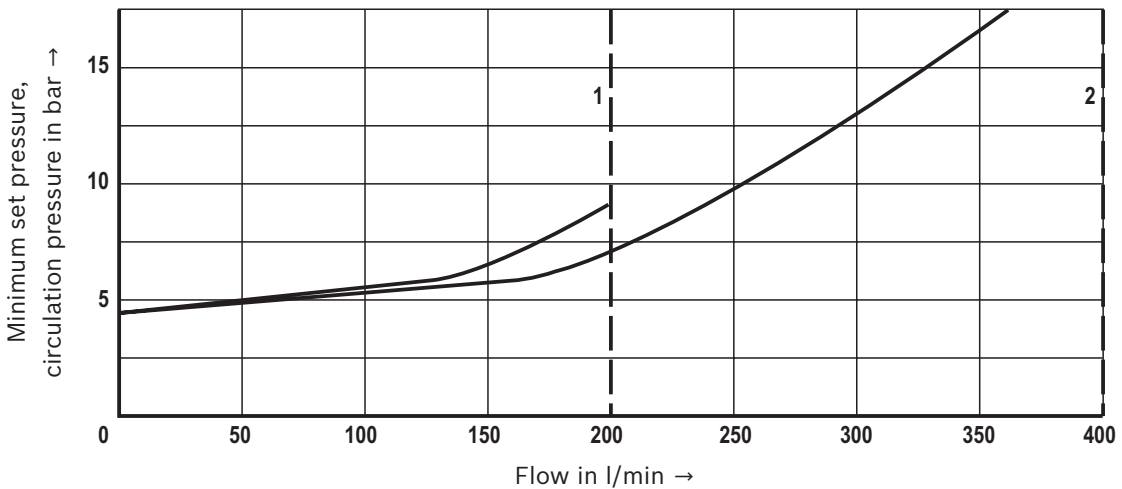

- 1 NG10
- 2 NG25

Notices:

The characteristic curves were measured with **external, depressurized pilot oil return.**

With internal pilot oil return, the inlet pressure increases by the output pressure present in port T.

¹⁾ The characteristic curves apply to the pressure at the valve output $p_T = 0 \text{ bar}$ across the entire flow range.

Characteristic curves: Threaded connection
(measured with HLP46, $\vartheta_{oil} = 40 \pm 5 \text{ }^\circ\text{C}$)

Minimum set pressure and circulation pressure dependent on the flow ¹⁾
Standard version

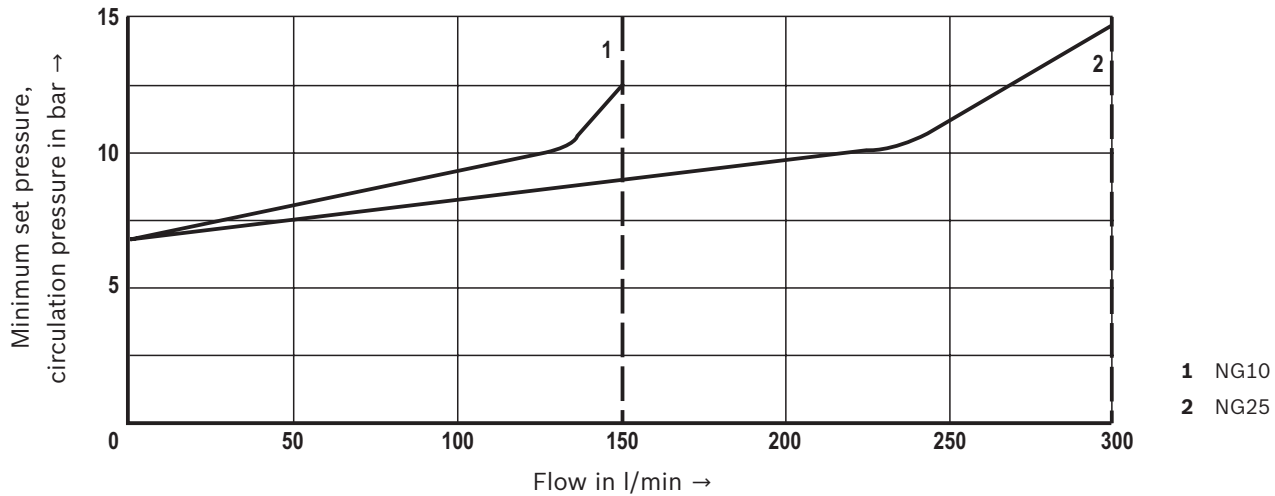

Minimum set pressure and circulation pressure dependent on the flow ¹⁾
Version "U"

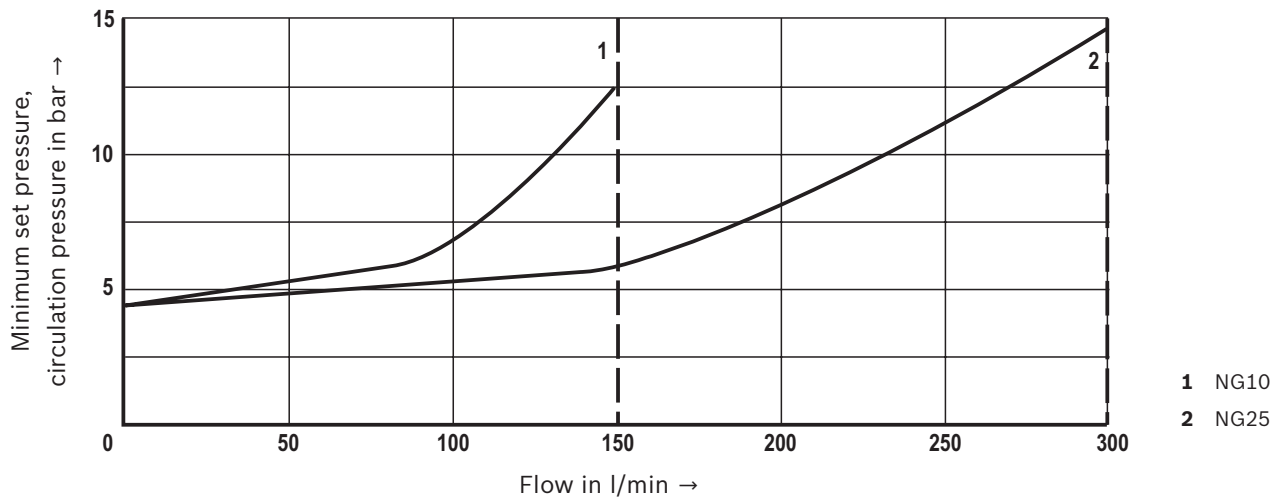

Notices:

The characteristic curves were measured with **external, depressurized pilot oil return**.

With internal pilot oil return, the inlet pressure increases by the output pressure present in port T.

¹⁾ The characteristic curves apply to the pressure at the valve output $p_T = 0 \text{ bar}$ across the entire flow range.

Dimensions: Subplate mounting – size 10
(dimensions in mm)

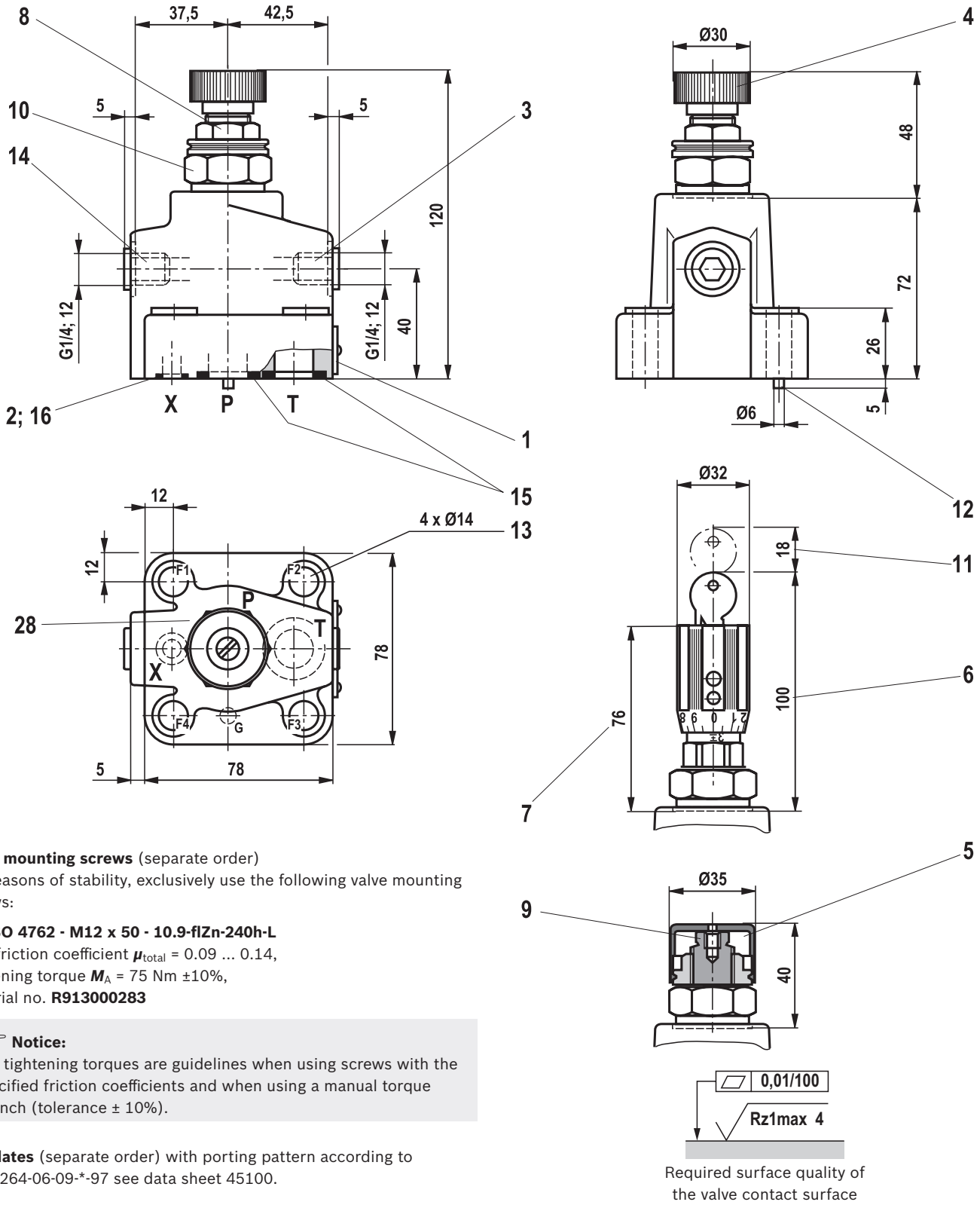

Valve mounting screws (separate order)
For reasons of stability, exclusively use the following valve mounting screws:

4 x ISO 4762 - M12 x 50 - 10.9-fIZn-240h-L
with friction coefficient $\mu_{total} = 0.09 \dots 0.14$,
tightening torque $M_A = 75 \text{ Nm} \pm 10\%$,
material no. **R913000283**

Notice:
The tightening torques are guidelines when using screws with the specified friction coefficients and when using a manual torque wrench (tolerance $\pm 10\%$).

Subplates (separate order) with porting pattern according to ISO 6264-06-09-*97 see data sheet 45100.

Item explanations see page 16.

Dimensions: Subplate mounting – size 25
(dimensions in mm)

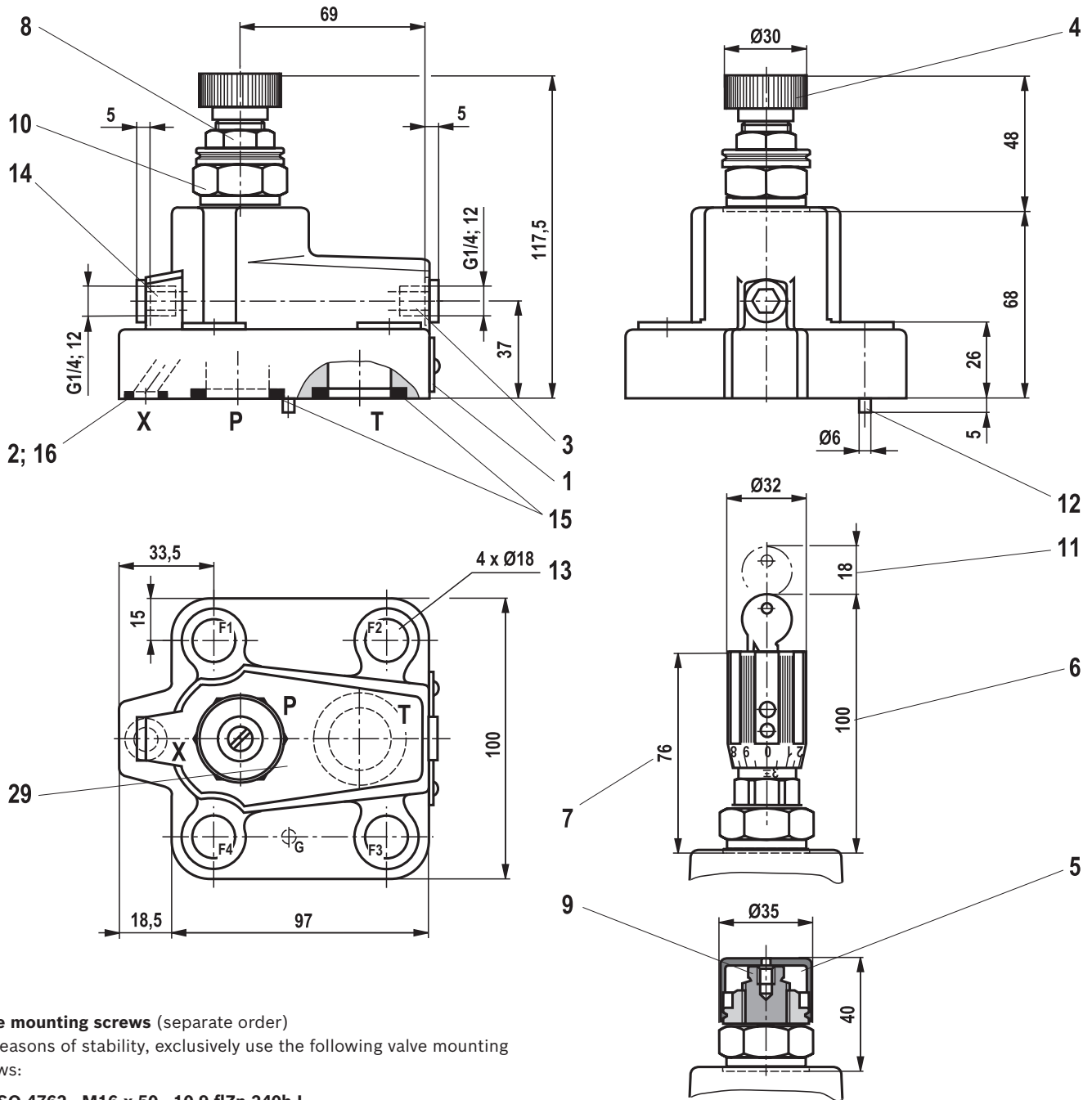

Valve mounting screws (separate order)

For reasons of stability, exclusively use the following valve mounting screws:

4 x ISO 4762 - M16 x 50 - 10.9-flZn-240h-L

with friction coefficient $\mu_{\text{total}} = 0.09 \dots 0.14$,
tightening torque $M_A = 185 \text{ Nm} \pm 10\%$,
material no. **R913000378**

Notice:

The tightening torques are guidelines when using screws with the specified friction coefficients and when using a manual torque wrench (tolerance $\pm 10\%$).

Subplates (separate order) with porting pattern according to ISO 6264-08-13-*97, see data sheet 45100.

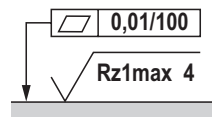

Required surface quality of the valve contact surface

Item explanations see page 16.

Dimensions: Threaded connection
(dimensions in mm)

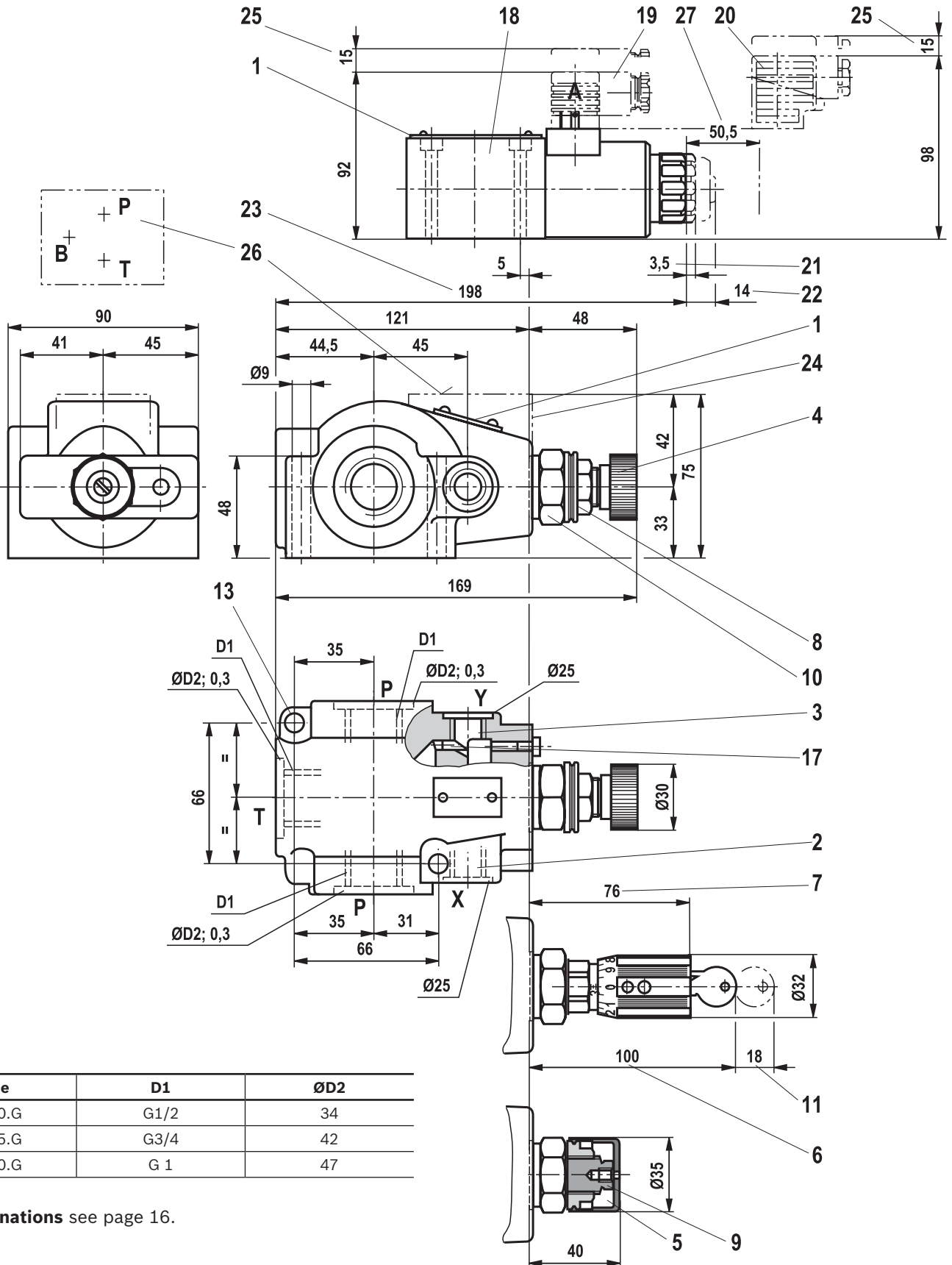

| Type | D1 | ØD2 |
|---------|------|-----|
| DB.10.G | G1/2 | 34 |
| DB.15.G | G3/4 | 42 |
| DB.20.G | G 1 | 47 |

Item explanations see page 16.

Dimensions: Screw-in cartridge valve
(dimensions in mm)

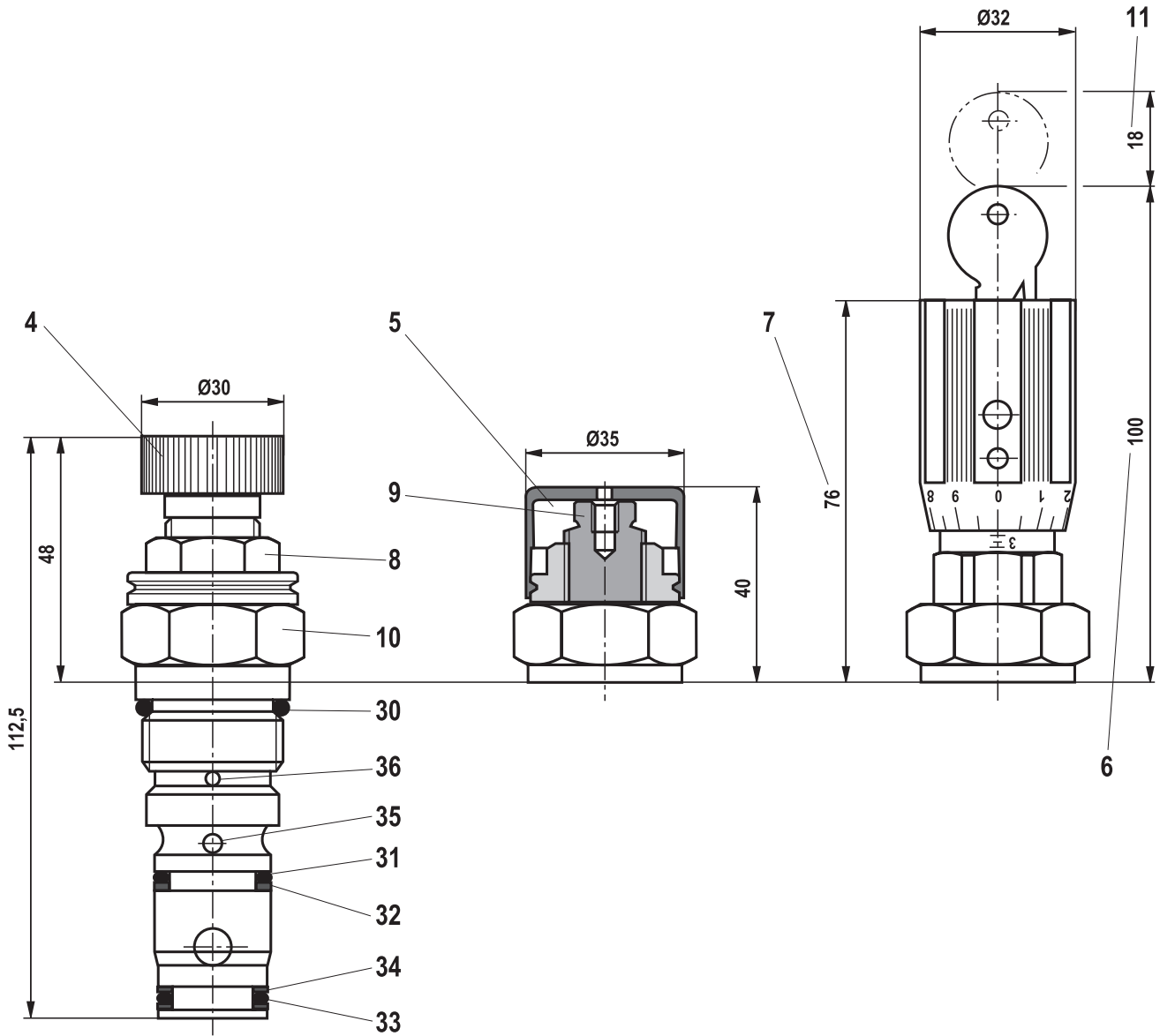

Item explanations see page 16.

Mounting cavity: Version "XY" and type-examination tested safety valves version "Y...E"
(dimensions in mm)

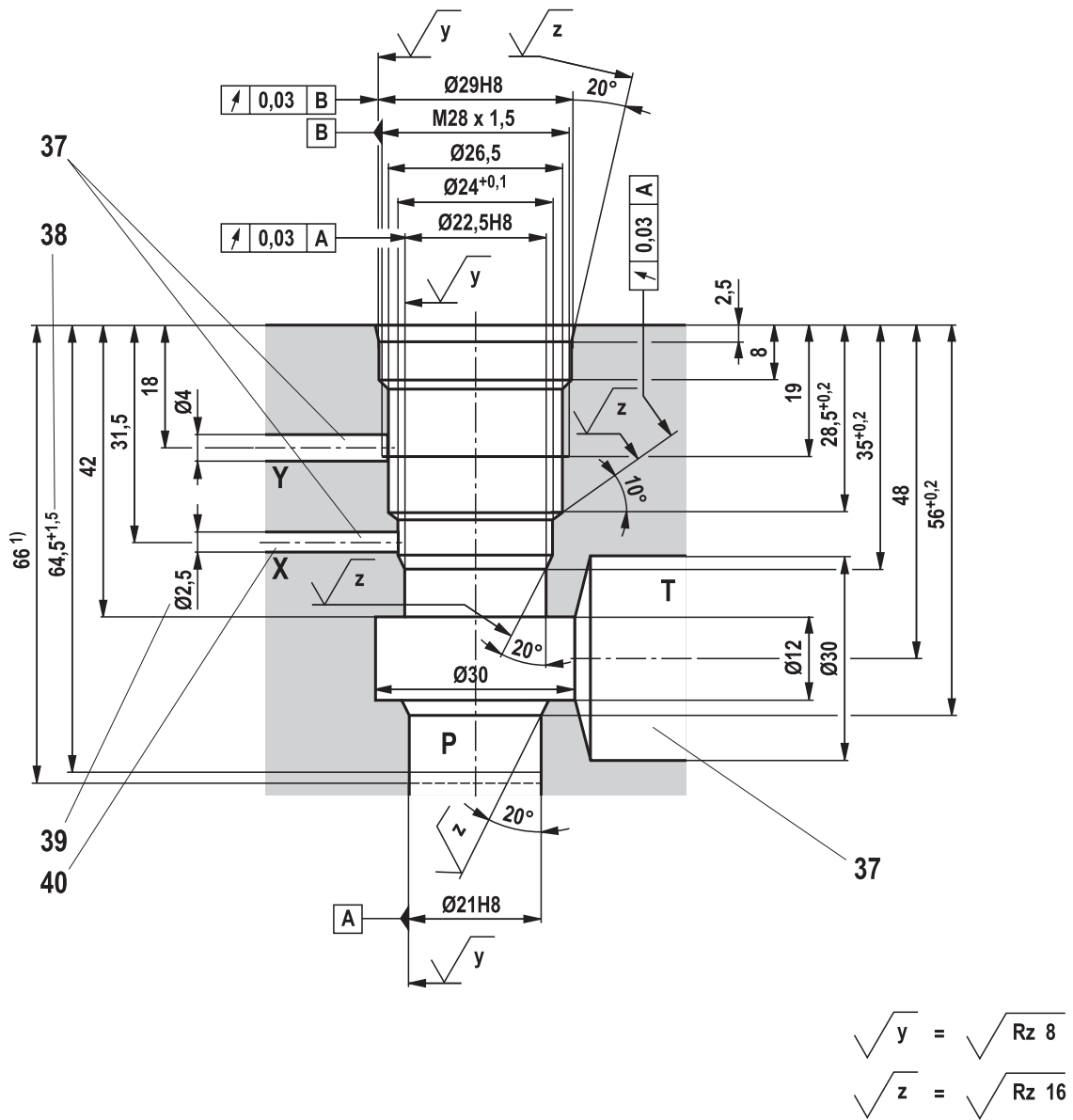

¹⁾ Installation depth

Item explanations see page 16.

Mounting cavity: Version "Y"
(dimensions in mm)

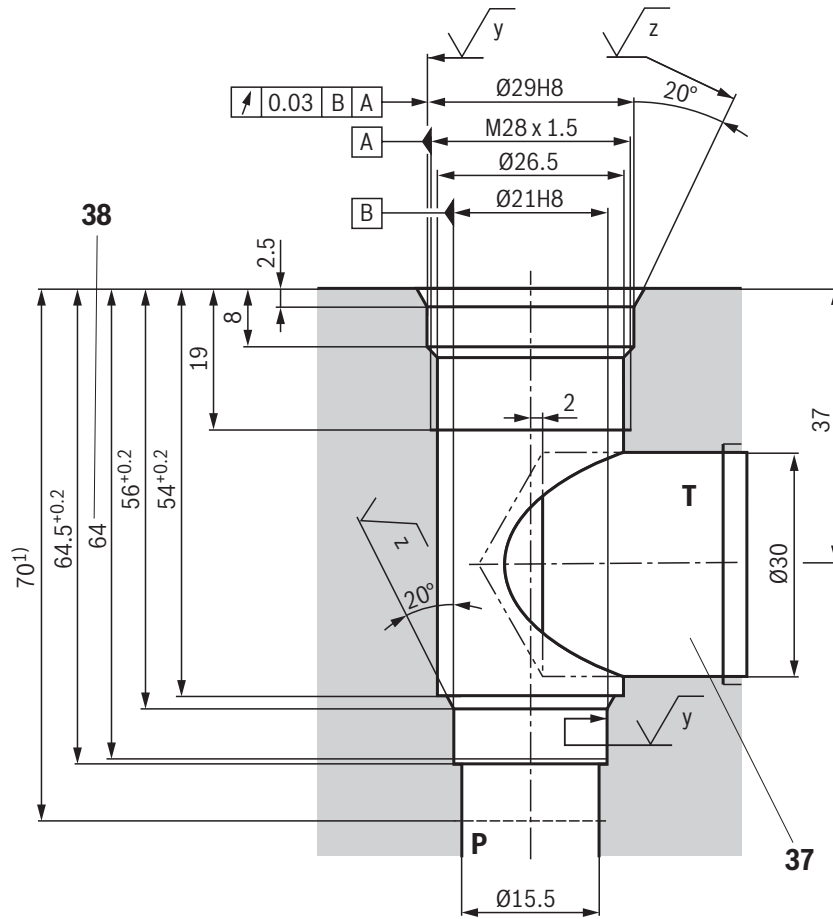

¹⁾ Installation depth

Item explanations see page 16.

Dimensions

- 1 Name plate
- 2 Port X for remote control, optional
- 3 Port Y for external pilot oil return
- 4 Adjustment type "1"
- 5 Adjustment type "2"
- 6 Adjustment type "3"
- 7 Adjustment type "7"
- 8 Lock nut wrench size 22, tightening torque $M_A = 10^{+5}$ Nm
- 9 Hexagon, wrench size 10
- 10 Hexagon, wrench size 30, tightening torque $M_A = 50$ Nm
- 11 Space required to remove the key
- 12 Locating pin
- 13 Valve mounting bores
- 14 Pressure gauge connection
- 15 Identical seal rings for ports P and T
- 16 Seal ring for port X
- 17 Grub screw is omitted with internal pilot oil return
- 18 Directional spool valve NG6, see data sheet 23178
- 19 Mating connector **without** circuitry
(separate order, see page 19)
- 20 Mating connector **with** circuitry
(separate order, see page 19)
- 21 Dimension for valve without manual override
- 22 Dimension for valve with manual override "N"
- 23 Dimension for valve with concealed manual override "N9"
- 24 Housing for version "W"
- 25 Space required to remove the mating connector
- 26 Valve contact surface; port A is not bored
- 27 Space required to remove the solenoid coil
- 28 Porting pattern according to ISO 6264-06-09-*-97
- 29 Porting pattern according to ISO 6264-08-13-*-97
- 30 Seal ring
- 31 Seal ring (omitted with version "Y")
- 32 Support ring (omitted with version "Y")
- 33 Seal ring
- 34 2 support rings
- 35 Bore for port X not available with version "Y"
- 36 Bore for port Y available with version "XY" and "Y"
- 37 ▶ Bore X, Y and T optionally at the circumference for version "XY"
▶ Bore T optionally at the circumference for version "Y" (no separate bore Y required; pilot oil return via bore T)
- 38 Depth of fit
- 39 Bore \varnothing 2.5 is only to be bored if necessary
- 40 Port X does not have to be bored for type-examination tested safety valves version "Y...E" as it does not have any function.

Ordering code: Type-examination tested safety valves type DB 20 K...E, component series 1X according to Pressure Equipment Directive 2014/68/EU

| NG | Type designation | Component marking | Maximum flow q_{Vmax} in l/min | Set response overpressure p in bar |
|----|------------------------------------------------------------------------------------------------------------------------|-----------------------------------------------|-------------------------------------|-----------------------------------------|
| 25 | DB 20 K <input type="text"/> ¹ -1X/ <input type="text"/> ² Y <input type="text"/> ³ E | TÜV.SV. <input type="text"/> -1001.14,4.F.G.p | 70 | 30 ... 60 |
| | | | 100 | 61 ... 110 |
| | | | 150 | 111 ... 210 |
| | | | 200 | 211 ... 315 |
| | | | 300 | 316 ... 350 |

Adjustment type

| | | |
|---|------------------------------------------------------------------------------------------------------------------------------|------------------|
| 1 | Hand wheel (pressure adjustment sealed, unloading or setting of a lower response pressure possible!) | 1 |
| | With sealed protective cap (no adjustment/unloading possible) | 2 |
| 2 | Pressure in the designation is to be entered by the customer, pressure adjustment ≥ 30 bar and possible in 5-bar steps. | e. g. 150 |

Seal material

| | | |
|---|---------------------------------------|----------------|
| 3 | NBR seals | no code |
| | FKM seals | V |
| | Information is entered at the factory | |

Deviating technical data: Type-examination tested safety valves type DB 20 K...E, component series 1X according to Pressure Equipment Directive 2014/68/EU ¹⁾

| hydraulic | | | |
|-----------------------------------|----------|--------------------|----------------------------------------------|
| Maximum counter pressure | - Port Y | bar | 0 |
| | - Port T | "No code" version | bar |
| | | "Y" version | 10 |
| Maximum flow | | | see preceding table |
| Hydraulic fluid | | | Mineral oil (HL, HLP) according to DIN 51524 |
| Hydraulic fluid temperature range | | °C | -10 ... +60 |
| Viscosity range | | mm ² /s | 12 ... 230 |

¹⁾ For applications outside these parameters, please consult us!

Safety instructions: Type-examination tested safety valves type DB 20 K...E, component series 1X according to Pressure Equipment Directive 2014/68/EU

- ▶ Before ordering a type-examination tested safety valve, it must be ensured that at the desired **response pressure p** , the maximum admissible **flow $q_{V \max}$** (= numerical value at the position of letter "G" in the component marking) of the safety valve is higher than the maximum possible flow of the system/accumulator to be secured. In this, the corresponding regulations have to be observed!
- ▶ According to the **Pressure Equipment Directive 2014/68/EU**, the increase in the system pressure due to the flow must not exceed 10% of the set response pressure (see component marking).
- ▶ The maximum admissible flow $q_{V \max}$ stated in the component marking must not be exceeded.
- ▶ Discharge lines of safety valves must end in a risk-free manner. The accumulation of fluids in the discharge lines must **not** be possible (see AD2000 - data sheet A2).



Always observe application notes!

- ▶ In the plant, the response pressure specified in the component marking is set with a flow of 2 l/min.
- ▶ The maximum admissible flow specified in the component marking applies to:
 - External pilot oil return **"Y"** without counter pressure in the pilot oil return line: admissible counter pressure in the discharge line (port T) < 10 bar.
- ▶ By removing a lead seal at the safety valve, the approval according to the Pressure Equipment Directive becomes void
- ▶ Mounting cavities (see page 14 and 15)
- ▶ The requirements of the Pressure Equipment Directives and of data sheet AD2000 A2 must be observed!

Mating connectors according to DIN EN 175301-803

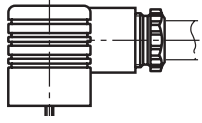
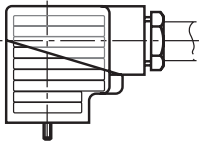
| | | | | |
|--------------------------------------------------------------|-----------------------------------------------------------------------------------|------------------------------------------------------------------------------------|--------------------------------|--------------------------------------------------------|
| For details and more mating connectors, see data sheet 08006 |  |  | | |
| | | Material no. | | |
| Color | Without circuitry | With indicator light 12 ... 240 V | With rectifier 12 ... 240 V | With indicator light and Z-diode-suppressor 24 V |
| gray | R901017010 | - | - | - |
| black | R901017011 | R901017022 | R901017025 | R901017026 |

General information

- ▶ The unloading function (directional valve function with version "W") must not be used for safety functions!
- ▶ With version "B", the lowest adjustable pressure (circulation pressure) is set in case of power failure or cable break. With version "A", the pressure limiting function is set in case of power failure or cable break.
- ▶ Hydraulic counter pressures in port T with internal pilot oil return and/or port Y with external pilot oil return add 1:1 to the response pressure of the valve set at the pilot control.

Example:

Pressure adjustment of the valve by spring preload (item 7 on page 5) in the pilot control valve/adjustment type

$$p_{\text{spring}} = 200 \text{ bar}$$

Hydraulic counter pressure in port T with internal pilot oil return $p_{\text{hydraulic}} = 50 \text{ bar}$

$$\Rightarrow \text{Response pressure} = p_{\text{spring}} + p_{\text{hydraulic}} = 250 \text{ bar}$$

Further information

- ▶ Safety equipment against excessive pressure – safety valves
- ▶ Subplates
- ▶ Hydraulic fluids on mineral oil basis
- ▶ Environmentally compatible hydraulic fluids
- ▶ Hydraulic valves for industrial applications
- ▶ Selection of the filters
- ▶ Information on available spare parts

Data sheet AD 2000 A 2

Data sheet 45100

Data sheet 90220

Data sheet 90221

Operating instructions 07600-B

www.boschrexroth.com/filter

www.boschrexroth.com/spc

Notes

Bosch Rexroth AG
Industrial Hydraulics
Zum Eisengießer 1
97816 Lohr am Main, Germany
Phone +49 (0) 93 52 / 40 30 20
my.support@boschrexroth.de
www.boschrexroth.de

© This document, as well as the data, specifications and other information set forth in it, are the exclusive property of Bosch Rexroth AG. It may not be reproduced or given to third parties without its consent.

The data specified above only serve to describe the product. No statements concerning a certain condition or suitability for a certain application can be derived from our information. The information given does not release the user from the obligation of own judgment and verification. It must be remembered that our products are subject to a natural process of wear and aging.