

Inline filter with filter element according to DIN 24550

Type 350LEN0040 to 1000; 350LE0130, 0150

RE 51422

Edition: 2019-12

Replaces: 07.11



350LEN_d

- ▶ Size as per **DIN 24550**: 0040 to 1000
- ▶ Other sizes: 0130, 0150
- ▶ Nominal pressure: 350 bar [5,079 psi]
- ▶ Connection sizes up to G2; SAE 2"; SAE 24
- ▶ Operating temperature: -10 °C to 100 °C [14 °F to 212 °F]

Features

Inline filters are used in hydraulic systems for separating solid materials from fluids and lubricating oils.

They come with the following features:

- ▶ Filter for inline installation
- ▶ Special, highly efficient filter materials
- ▶ Filtration of very fine particles and high dirt holding capacity across a broad pressure differential range
- ▶ High collapse rating of the filter elements
- ▶ Equipped standard with mechanical optical maintenance indicator with memory function
- ▶ Various, optional electronic switching elements, modular design
- ▶ Optional bypass valve integrated in the filter housing
- ▶ High filtration performance due to tangential, cyclonic flow path
- ▶ Additional configurations available for special fluids

Contents

Features	1
Filter ordering code	2, 3
Preferred types	4
Accessories ordering code	5
Filter design	6
Symbols	7
Function, cross-section	8
Technical data	9, 10
Compatibility with permitted hydraulic fluids	11
Dimensions	12
Maintenance indicator	13
Spare parts ordering codes	14 ... 16
Assembly, commissioning, maintenance	17
Tightening torques	18
Directives and standardization	18, 19

Filter ordering code

01	02	03		04	05	06		07		08		09		10
350LE			-				-		-		-		-	

Series

01	Inline filter, 350 bar [5,079 psi]	350LE
----	------------------------------------	-------

Filter element

02	With filter element as per DIN 24550	N
----	---	---

Size

03	LEN... (Filter element as per DIN 24550)	0040 0063 0100 0160 0250 0400 0630 1000
	LE... (Filter element as per Bosch Rexroth standard)	0130 0150

Filter rating in μm

04	Absolute (ISO 16889; $\beta_{x(c)} \geq 200$)	Glass fiber material, not cleanable	PWR3 PWR6 PWR10 PWR20
	Nominal	Stainless steel wire mesh, cleanable	G10 G25 G40 G60 G100

Pressure differential

05	Max. admissible filter element pressure differential: 30 bar [435 psi], filter with bypass valve	A
	Max. admissible filter element pressure differential: 330 bar [4,786 psi], filter has no bypass valve	B

Element design

06	Standard adhesive with galvanized steel	00
	Special adhesive with stainless steel	HV ¹⁾

Maintenance indicator

07	Maintenance indicator, mech. visual, switching pressure: 2.2 bar [32 psi] – bypass cracking pressure: 3.5 bar [51 psi]	V2.2
	Maintenance indicator, mech. visual, switching pressure: 5.0 bar [72.5 psi] – bypass cracking pressure: 7 bar [102 psi]	V5.0
	Maintenance indicator, mech. visual, switching pressure 8.0 bar [116 psi] – no bypass valve	V8.0

Seal

08	NBR seal	M
	FKM seal	V
	EPDM seal	E ²⁾

Filter ordering code

01	02	03	04	05	06	07	08	09	10
350LE			-			-	-	-	-

Connection

09	Installation size		0040	0063-0100	0130-0150	0160-0400	0630-1000		
	Connection								
	G1/2	Pipe thread as per ISO 228	●	X				R2	
	G3/4		X	X				R3	
	G1		X	●	X			R4	
	G1 1/4				●	X		R5	
	G1 1/2				X	●		R6	
	G2							●	R8
	SAE 1 1/2"	SAE flange 6,000 psi				X		S6	
	SAE 2"						X	S8	
	SAE 10"	Pipe thread as per SAE J1926	X					U3	
	SAE 12"			X				U4	
	SAE 20"				X			U5	
	SAE 24"						X	U6	
			●	Standard connection					
			X	Alternative connection option					

Supplementary information

10	Manufacturer's inspection certificate M as per DIN 55350 T18	Z1
----	--	-----------

- 1) Only with FKM or EPDM seal
- 2) Only with maintenance indicator V5.0

Order example:

350LEN0100-PWR10A00-V5.0-M-R4

Other versions are available on request.

Preferred types

350LE(N), flow specifications for 30 mm²/s [143 SUS]

Inline filter, 3 µm filter rating

Type	Flow in l/min [US gpm] whereas $\Delta p = 1.5 \text{ bar } [21.76 \text{ psi}]^{1)}$	Material no. Filter				Replacement element material no.
		...R2	...R4	...R5	...R6	
350LEN0040-PWR3A00-V5.0-M-...	32 [8.5]	...R2	R928033024	...U3	R928033216	R928006645
350LEN0063-PWR3A00-V5.0-M-...	48 [12.7]	...R4	R928033025	...U4	R928033217	R928006699
350LEN0100-PWR3A00-V5.0-M-...	64 [16.9]	...R4	R928033026	...U4	R928033218	R928006753
350LE0130-PWR3A00-V5.0-M-...	103 [27.2]	...R5	R928033027	...U5	R928033219	R928022274
350LE0150-PWR3A00-V5.0-M-...	127 [33.6]	...R5	R928033028	...U5	R928033220	R928022283
350LEN0160-PWR3A00-V5.0-M-...	160 [42.3]	...R6	R928033029	...U6	R928033221	R928006807
350LEN0250-PWR3A00-V5.0-M-...	267 [70.5]	...R6	R928033030	...U6	R928033222	R928006861
350LEN0400-PWR3A00-V5.0-M-...	335 [88.5]	...R6	R928033031	...U6	R928033223	R928006915
350LEN0630-PWR3A00-V5.0-M-...	449 [118.6]	...R8	R928034432	...S8	R928034448	R928006969
350LEN1000-PWR3A00-V5.0-M-...	597 [157.7]	...R8	R928034433	...S8	R928034449	R928007023

Inline filter, 6 µm filter rating

Type	Flow in l/min [US gpm] whereas $\Delta p = 1.5 \text{ bar } [21.76 \text{ psi}]^{1)}$	Material no. Filter				Replacement element material no.
		...R2	...R4	...R5	...R6	
350LEN0040-PWR6A00-V5.0-M-...	41 [10.8]	...R2	R928033280	...U3	R928033472	R928006646
350LEN0063-PWR6A00-V5.0-M-...	69 [18.2]	...R4	R928033281	...U4	R928033473	R928006700
350LEN0100-PWR6A00-V5.0-M-...	104 [27.5]	...R4	R928033282	...U4	R928033474	R928006754
350LE0130-PWR6A00-V5.0-M-...	125 [33]	...R5	R928033283	...U5	R928033475	R928022275
350LE0150-PWR6A00-V5.0-M-...	135 [35.7]	...R5	R928033284	...U5	R928033476	R928022284
350LEN0160-PWR6A00-V5.0-M-...	265 [70]	...R6	R928033285	...U6	R928033477	R928006808
350LEN0250-PWR6A00-V5.0-M-...	320 [84.5]	...R6	R928033286	...U6	R928033478	R928006862
350LEN0400-PWR6A00-V5.0-M-...	400 [105.7]	...R6	R928025783	...U6	R928033479	R928006916
350LEN0630-PWR6A00-V5.0-M-...	520 [137.4]	...R8	R928034464	...S8	R928034480	R928006970
350LEN1000-PWR6A00-V5.0-M-...	635 [167.8]	...R8	R928034465	...S8	R928034481	R928007024

Inline filter, 10 µm filter rating

Type	Flow in l/min [US gpm] whereas $\Delta p = 1.5 \text{ bar } [21.76 \text{ psi}]^{1)}$	Material no. Filter				Replacement element material no.
		...R2	...R4	...R5	...R6	
350LEN0040-PWR10A00-V5.0-M-...	51 [13.5]	...R2	R928033536	...U3	R928033728	R928006647
350LEN0063-PWR10A00-V5.0-M-...	76 [20.1]	...R4	R928033537	...U4	R928033729	R928006701
350LEN0100-PWR10A00-V5.0-M-...	100 [26.4]	...R4	R928033538	...U4	R928033730	R928006755
350LE0130-PWR10A00-V5.0-M-...	191 [50.5]	...R5	R928025653	...U5	R928033731	R928022276
350LE0150-PWR10A00-V5.0-M-...	202 [53.4]	...R5	R928028868	...U5	R928033732	R928022285
350LEN0160-PWR10A00-V5.0-M-...	261 [69]	...R6	R928033541	...U6	R928033733	R928006809
350LEN0250-PWR10A00-V5.0-M-...	330 [87.2]	...R6	R928033542	...U6	R928033734	R928006863
350LEN0400-PWR10A00-V5.0-M-...	409 [108.1]	...R6	R928033543	...U6	R928033735	R928006917
350LEN0630-PWR10A00-V5.0-M-...	590 [155.9]	...R8	R928034496	...S8	R928034512	R928006971
350LEN1000-PWR10A00-V5.0-M-...	650 [171.7]	...R8	R928034497	...S8	R928034513	R928007025

¹⁾ Measured pressure differential across filter and measuring equipment in accordance with ISO 3968. The measured pressure differential at the maintenance indicator is lower.

Accessories ordering code
(dimensions in mm [inch])

Electronic switching element for maintenance indicators

01	02	03
WE	-	-

Maintenance indicator

01	Electronic switching element	WE
----	------------------------------	-----------

Type of signal

02	1 switching point	1SP
	2 switching points, 3 LEDs	2SP
	2 switching points, 3 LEDs and signal suppression up to 30 °C [86 °F]	2SPSU

Plug

03	M12x1, 4-pole round plug-in connection	M12x1
	2-pole rectangular plug-in connection, design A as per EN 175301-803	EN 175301-803

Material numbers for electronic switching elements

Material no.	Type	Signal	Switching points	Plug	LEDs
R928028409	WE-1SP-M12x1	Changeover	1	M12x1	0
R928028410	WE-2SP-M12x1	Normally open (at 75%)/ normally closed contact (at 100%)	2		3
R928028411	WE-2SPSU-M12x1				
R928036318	WE-1SP-EN175301-803	Normally closed contact	1	EN 175301-803	0

Mating connectors (max. admissible voltage: 50 V)

For electronic switching element with M12x1 round plug-in connection

Mating connector fitting M12x1,
4-pole K24 with screw connection, Pg9 cable gland.

Material no. R900031155

Mating connector fitting M12x1,
4-pole K24-3m with potted-in PVC cable, 3 m long.
Line cross-section: 4 x 0.34 mm²

Core marking: **1** brown **2** white
 3 blue **4** black

Material no. R900064381

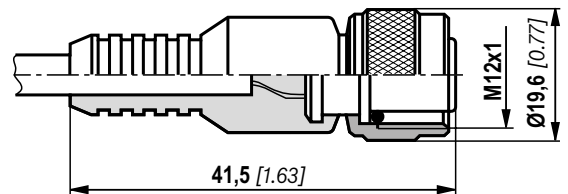
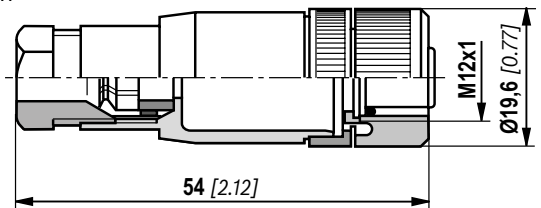

For more round plug-in connections, see data sheet 08006.

Order example:

Inline filter with mechanical visual maintenance indicator for $p_{nom} = 350 \text{ bar}$ [5,079 psi] with bypass valve, size 0100, with 10 µm filter element and M12x1 electronic switching element with 1 switching point for HLP mineral oil hydraulic fluid as per DIN 51524.

Filter with mech. visual maintenance indicator:	350LEN0100-PWR10A00-V5.0-M-R4	Material no. R928033538
Electronic switching element:	WE-1SP-M12x1	Material no. R928028409
Mating connector:	Mating connector fitting M12x1, 4-pole K24	Material no. R900031155

Filter design

Easy selection of the filter size is made possible by the FilterSelect online tool. The filter can be designed using the operating pressure, flow and fluid system parameters. The required filter rating is based on the application, the sensitivity to contamination of the components and the environmental conditions.

The program leads you through the menu on a step-by-step basis.

A documentation of the filter selection can finally be created in the form of a PDF file. This file contains the entered parameters, the designed filter with material number including spare parts, and the pressure loss curves.

Link FilterSelect:

<http://filtersselect.boschrexroth.com/rexfilter/>

Other languages can be selected using the page navigation.

Home Language About us Legal notice www.bosch.com

Rexroth
Bosch Group

www.boschrexroth.com Contact

Bosch Rexroth FilterSelect

standard search

application: hydraulics for industrial use and applications with lubricating oil

Product category: please select

type: please select

pressure range: please select

filter material: please select

fineness: please select

volume flow rate: [] [l/min]

viscosity:
* = working point

kin viscosity 1: 32 [mm²/s]

search via type of medium full-text search medium

please select

please select

temp 1: [] [°C] [] [°F] kin viscosity 1: [] [mm²/s]

dyn. Viscosity 1: [] [cP] density 1: [] [kg/dm³] kin viscosity 1: [] [mm²/s]

collapse pressure resistance according to ISO 2941: 30 bar

Start search

Symbols

Inline filter
with bypass
and mechanical indicator

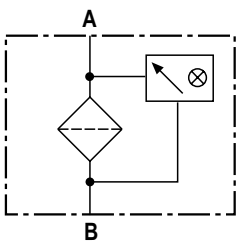
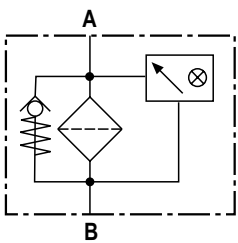

Inline filter,
no bypass,
with mechanical indicator

**Electronic switching element
for maintenance indicator**

Switching element Plug

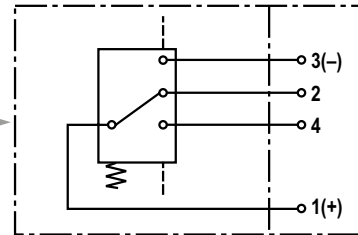

WE-1SP-M12x1

Switching element Plug

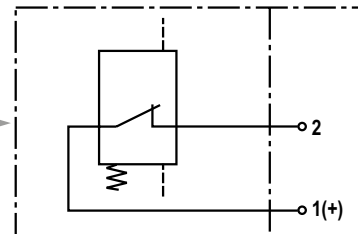

WE-1SP-EN175301-803

Switching element Plug

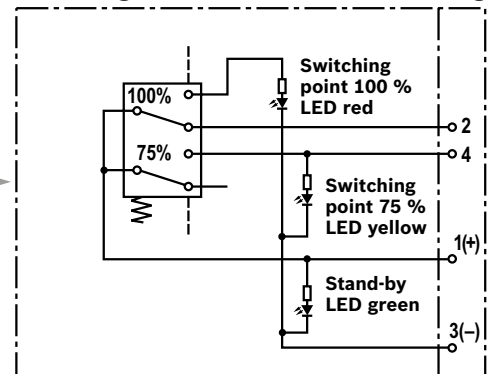

WE-2SP-M12x1

Circuit diagram drawn in plugged condition (operating state)

Switching element Plug

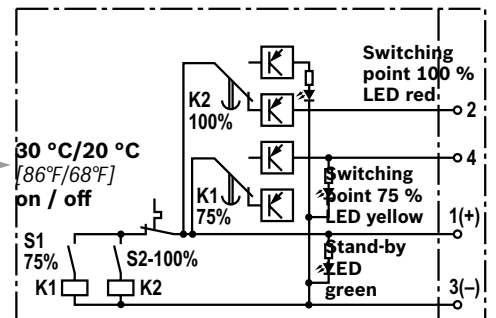

WE-2SPSU-M12x1

Circuit diagram drawn in plugged condition at temperature > 30 °C [86 °F] (operating state)

Function, cross-section

The 350LE(N) inline filter is designed for direct installation into pressure lines.

It consists primarily of a filter head (1), a threaded filter bowl (2), a filter element (3) and a mechanical optical maintenance indicator (4). For filters with low collapse filter elements (= pressure differential code letter A), a bypass valve (5) comes standard.

The fluid passes through the inlet to the filter element, where it is cleaned. Any dirt particles filtered out collect in the filter element. The filtered fluid then enters the hydraulic circuit through the outlet.

The filter housing and all connection elements are designed so that pressure spikes – as they may occur, e.g., due to an accelerated fluid quantity from large control valves opening abruptly – can be safely absorbed. Sizes 0160 and larger come with a drain screw (6) standard. Size 1000 comes with a two-part filter bowl, with the filter bowl fixed to prevent the bowl from spinning in the filter head.

An electronic switching element (7) can be added to the mechanical optical maintenance indicator in order to integrate it into an electric circuit. The electronic switching element must be attached to the mechanical visual maintenance indicator and held with the locking ring supplied. The electronic switching elements are connected with a mating connector or cable connection. The electronic switching element must be ordered separately.

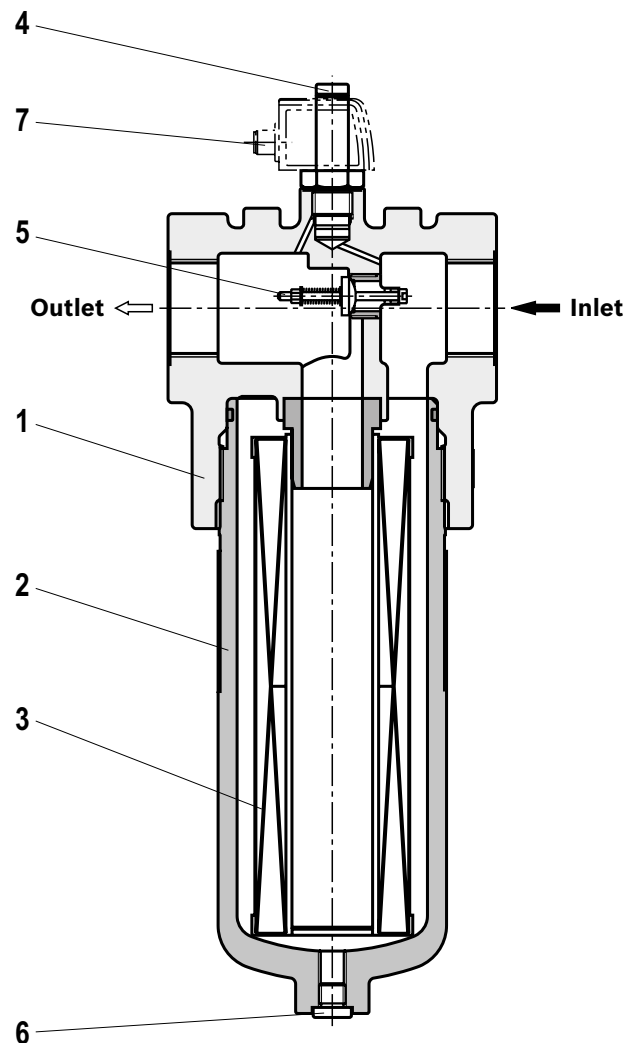

WARNING

- If the maintenance indicator is ignored when an element change is required, there is the possibility the filter will go into bypass and contaminated oil will pass to the clean side of the filter outlet. Therefore the filtration effectiveness is no longer guaranteed.

Technical data

(Please consult us for applications outside these parameters)

General							
Installation position	Vertical						
Ambient temperature range	°C [°F]	-10 to +65 [14 to 149] (down to -30 [-22] for brief periods)					
Storage conditions	▶ NBR/EPDM seal	°C [°F]	-40 to 65 [-40 to 149]; max. relative air humidity: 65%				
	▶ FKM seal	°C [°F]	-20 to 65 [-4 to 149]; max. relative air humidity: 65%				
Weight	▶ Filter	Size	0040	0063	0100	0130	0150
		kg [lbs]	4.4 [9.7]	5.0 [11.1]	5.9 [13.0]	10.5 [23.2]	11.2 [24.8]
		Size	0160	0250	0400	0630	1000
		kg [lbs]	17.2 [30.0]	19.5 [43.1]	23.0 [50.8]	45.0 [99.5]	93.0 [205.6]
		▶ Filter bowl	Size	0040	0063	0100	0160
	kg [lbs]	1.3 [2.9]	1.3 [2.9]	2.1 [4.6]	5.5 [12.1]		
	Size	0250	0400	0630	1000		
	kg [lbs]	8.0 [17.6]	12.2 [26.9]	21.4 [47.2]	Filter pipe ¹⁾	45.3 [99.8]	
	End cap	2.0 [4.4]					
	Flow	Size	0040	0063	0100	0130	0150
l [US gal]		0.3 [0.1]	0.4 [0.1]	0.5 [0.1]	0.9 [0.2]	1.1 [0.3]	
Size		0160	0250	0400	0630	1000	
l [US gal]		1.3 [0.3]	1.9 [0.5]	3.0 [0.8]	4.5 [1.2]	6.5 [1.7]	
Material	▶ Filter head	Ductile iron					
	▶ Filter bowl	Steel					
	▶ Bypass valve	Aluminum/steel/POM					
	▶ Seals	NBR or FKM					
	▶ Visual maintenance indicator	Brass					
	▶ Electronic switching element	Nylon 6 plastic					
Hydraulics							
Max. operating pressure	bar [psi]	350 [5,079]					
Hydraulic fluid temperature range	°C [°F]	-10 to 100 [14 to 212] (down to -30 [-22] for brief periods)					
Min. medium conductivity	pS/m	300					
Fatigue strength as per ISO 10771	load cycles	> 10 ⁶ at max. operating pressure					
Maintenance indicator pressure measurement type	Pressure differential						
Assignment: Maintenance indicator response pressure/ bypass valve cracking pressure	bar [psi]	Maintenance indicator response pressure	Bypass valve cracking pressure				
		2.2 ± 0.3 [31.9 ± 4.4]	3.5 ± 0.35 [50.8 ± 5.1]				
		5.0 ± 0.5 [72.5 ± 7.3]	7.0 ± 0.5 [101.5 ± 7.3]				
	bar [psi]	8.0 ± 0.8 [116 ± 11.6]	No bypass valve				
Direction of filtration	From the outside to the inside						

¹⁾ This weight is not relevant to changing the filter element, since only the cap has to be unscrewed.

Technical data

(Please consult us for applications outside these parameters)

Electrical (electronic switching element)					
Electrical connection	Version	M12x1, 4-pole round plug-in connection			EN 175301-803 standard connection
		WE-1SP-M12x1	WE-2SP-M12x1	WE-2SPSU-M12x1	WE-1SP-EN175301-803
Contact load, DC voltage	$A_{max.}$	1			
Voltage range	$V_{max.}$	150 (AC/DC)	10 – 30 (DC)	250 (AC) / 200 (DC)	
Max. switching power with resistive load	W	20			70
Switching type	► 75% signal	–	Normally open contact		–
	► 100% signal	Changeover	Normally closed contact		Normally closed contact
	► 2SPSU			Signal inter-connection at 30 °C [86 °F], return switching at 20 °C [68 °F]	
LED indicators in 2SP electronic switching elements			Stand-by (LED green) 75% switching point (LED yellow) 100% switching point (LED red)		
IP rating as per EN 60529	IP	67			65
Ambient temperature range	°C [°F]	-25 to 85 [-13 to 185]			
Include spark extinguishing for DC voltage above 24 V to protect the switching contacts.					
Weight	Electronic switching element	kg [lbs]	0.1 [0.22]		

Filter element					
Glass fiber material PWR..		Inorganic fiber-based single-use element			
		Filtration ratio as per ISO 16889 up to $\Delta p = 5$ bar [72.5 psi]		Best oil cleanliness as per ISO 4406 [SAE-AS 4059]	
	PWR20	$\beta_{20}(c) \geq 200$		19/16/12 – 22/17/14	
	PWR10	$\beta_{10}(c) \geq 200$		17/14/10 – 21/16/13	
	PWR6	$\beta_6(c) \geq 200$		15/12/10 – 19/14/11	
	PWR3	$\beta_5(c) \geq 200$		13/10/8 – 17/13/10	
Admissible pressure differential	► A	bar [psi]	30 [435]		
	► B	bar [psi]	330 [4,785]		

For detailed information on Rexroth filter elements, see data sheet 51420.

Compatibility with permitted hydraulic fluids

Hydraulic fluid	Classification	Suitable sealing materials	Suitable adhesive	Standards	
Mineral oil	HLP	NBR	Standard	DIN 51524	
Biodegradable	▶ Water insoluble	HETG		NBR	VDMA 24568
		HEES		FKM	
	▶ Water soluble	HEPG		FKM	VDMA 24568
Flame-resistant	▶ Waterless	HFDR, HFDR		FKM	VDMA 24317
		HFAS		NBR	
	▶ Aqueous	HFAE		NBR	DIN 24320
		HFC		NBR	VDMA 24317
	▶ Skydrol	–		EPDM	Special “H”



Important information on hydraulic fluids:

- ▶ For more information and data on the use of other hydraulic fluids, see data sheet 90220 or contact us.
 - ▶ **Flame-resistant, aqueous:** Due to possible chemical reactions with materials or machine and system component surface coating, the service life with these hydraulic fluids may be less than expected.
 - ▶ **Biodegradable:** If filter materials made of filter paper are used, the filter life may be shorter than expected due to material incompatibility and swelling.
- Do not use filter materials made of filter paper P, use filter elements with glass fiber filter material instead.

Dimensions: 350LE(N) sizes 0040 to 1000
(Dimensions in mm [inch])

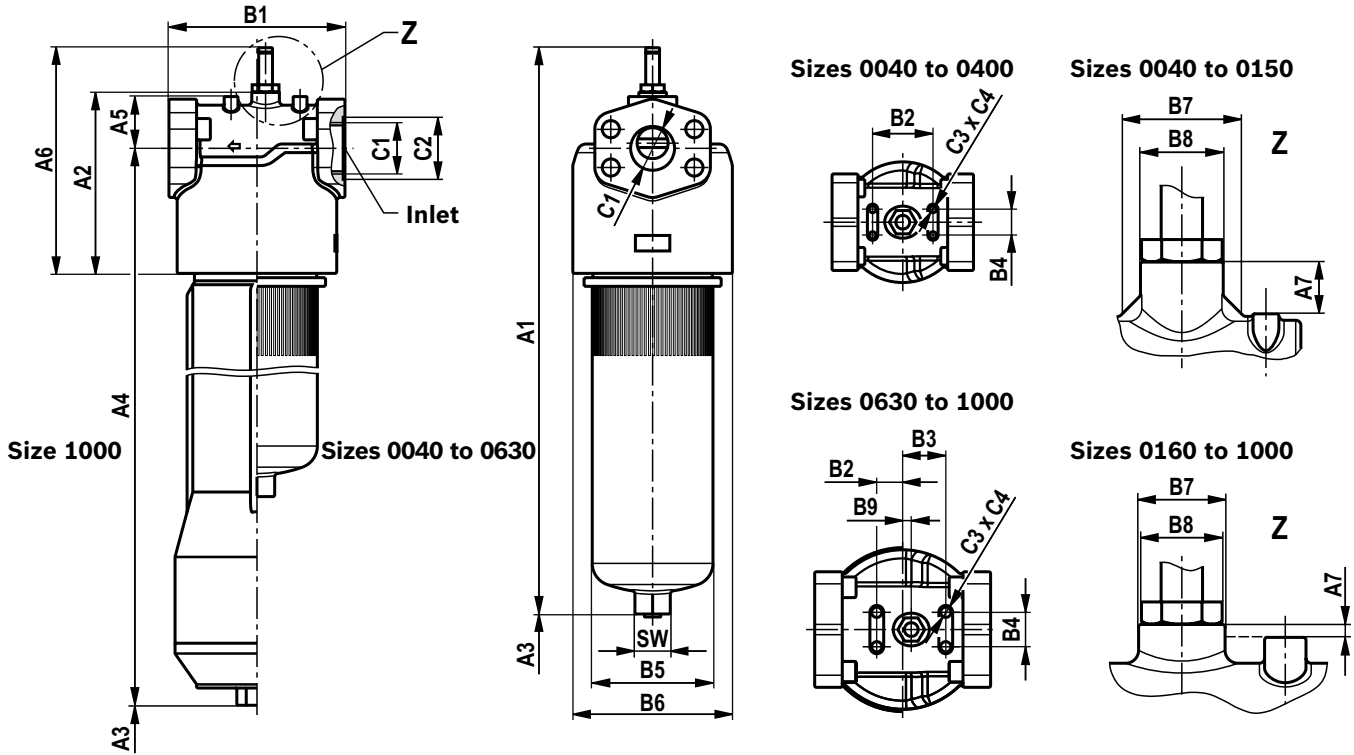

Type 350...	A1	A2	A3 ¹⁾	A4	A5	A6	A7	B1 ²⁾	B2	B3	ØB4
LEN0040	203 [7.99]	115 [4.53]	80 [3.15]	158 [6.22]	25 [0.98]	167 [6.57]	20 [0.79]	92 [3.62]	65 [2.56]	-	30 [1.18]
LEN0063	266 [10.47]			221 [8.70]							
LEN0100	356 [14.02]			311 [12.24]							
LE0130	328 [12.91]	150 [5.91]	140 [5.51]	273 [10.75]	40 [1.57]	202 [7.95]	15 [0.59]	132 [5.20]	80 [3.15]	-	30 [1.18]
LE0150	364 [14.33]			324 [12.76]							
LEN0160	322 [12.68]	170 [6.69]	140 [5.51]	262 [10.31]	50 [1.97]	222 [8.74]	10 [0.39]	164 [6.46]	70 [2.76]	-	30 [1.18]
LEN0250	412 [16.22]			352 [13.86]							
LEN0400	562 [22.13]			502 [19.76]							
LEN0630	605 [23.82]			210 [8.27]							
LEN1000	843 [33.19]		650 [25.59]	778 [30.63]							

Type 350...	ØB5	ØB6	ØB7	ØB8	B9	C1 connection						C3	C4	SW
						R... (ISO 228)	ØC2	U... (SAE J1926)	ØC2	S... (SAE flanges)				
LEN0040	64 [2.52]	85 [3.35]	47 [1.85]	32 [1.26]	-	G1/2	28 [1.10]	SAE 10" 7/8-14 UNF-2B	34 [1.34]	-	M6	8 [0.31]	32 [1.26]	
LEN0063						G1	41 [1.61]	SAE 12" 1 1/16-12 UN-2B						
LEN0100						G1 1/4	51 [2.01]	SAE 20" 1 5/8-12 UN-2B	58 [2.28]					
LE0130	92 [3.62]	118 [4.65]				G1 1/2	56 [2.20]	SAE 24" 1 7/8-12 UN-2B	65 [2.56]	SAE 1 1/2" 6,000 psi	M8			
LE0150														
LEN0160	114 [4.49]	140 [5.51]												
LEN0250														
LEN0400														
LEN0630	140 [5.51]	185 [7.28]	32 [1.26]		10 [0.39]	G2	72 [2.83]	-		SAE 2" 6,000 psi	M12	12 [0.47]	41 [1.61]	
LEN1000	190 [7.48]													

¹⁾ Servicing height for changing filter element ²⁾ Dimension B1 is reduced by 4 mm [0.16 in] for SAE flanges

Maintenance indicator
(Dimensions in mm [inch])

Pressure differential indicator with mounted M12x1 switching element

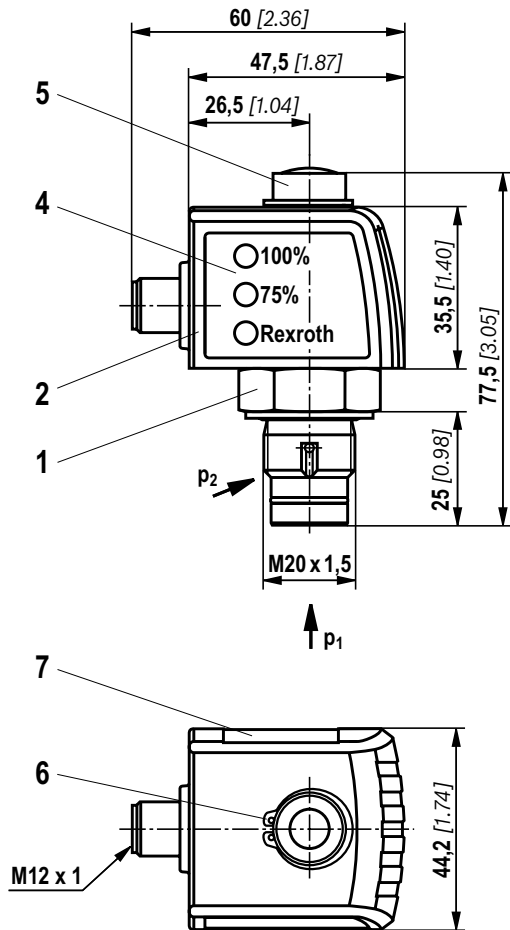

Pressure differential indicator with mounted EN 175301-803 switching element

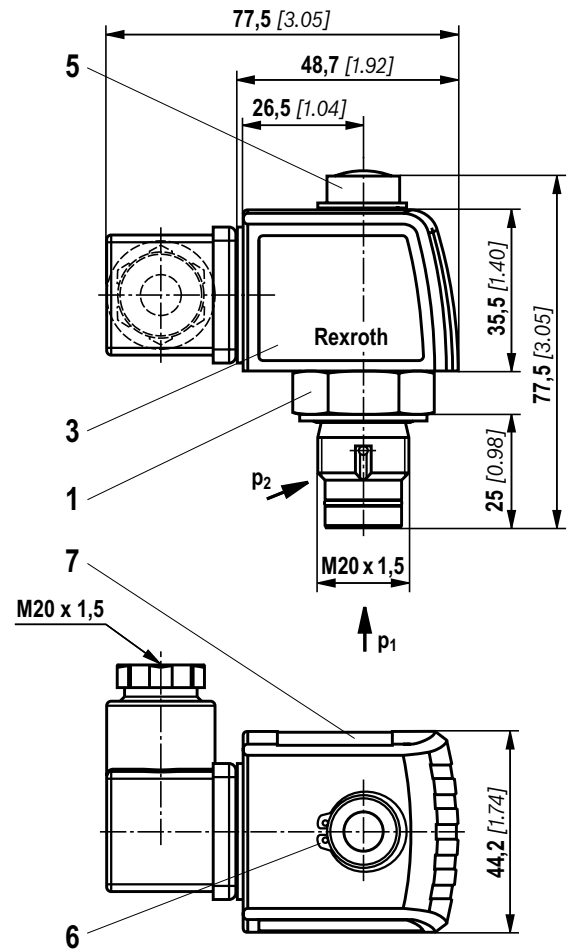

- 1 Mechanical optical maintenance indicator; max. tightening torque $M_{A\max} = 50 \text{ Nm}$ [36.88 lb-ft]
- 2 Switching element with locking ring for electrical maintenance indicator (rotatable 360°); M12x1, 4-pole round plug-in connection
- 3 Switching element with locking ring for electrical maintenance indicator (rotatable 360°); EN 175301-803 rectangular plug-in connection
- 4 Housing with three LEDs: 24 V =
green: Stand-by
yellow: Switching point 75%
red: Switching point 100%
- 5 Visual indicator with memory function
- 6 16x1 DIN 471 locking ring,
Material no. R900003923
- 7 Name plate

Important:

Illustration includes a mechanical visual maintenance indicator (1) and electronic switching element (2), (3).

Spare parts ordering codes

Filter element

01	02	03	04	05	06	07
2.			-		-	0

Filter element

01	Design	2.
----	--------	----

Size

02	LEN... (Filter element as per DIN 24550)	0040 0063 0100 0160 0250 0400 0630 1000
	LE... (Filter elements as per Bosch Rexroth standard)	0130 0150

Filter rating in μm

03	Absolute (ISO 16889; $\beta_{x(c)} \geq 200$)	Glass fiber material, not cleanable	PWR3 PWR6 PWR10 PWR20
	Nominal	Stainless steel wire mesh, cleanable	G10 G25 G40 G60 G100

Pressure differential

04	Max. admissible filter element pressure differential: 30 bar [435 psi], filter with bypass valve	A
	Max. admissible filter element pressure differential: 330 bar [4,786 psi], filter has no bypass valve	B

Element design

05	Standard adhesive with galvanized steel	00
	Special adhesive with stainless steel	HV ¹⁾

Bypass valve

06	Without bypass valve	0
----	-----------------------------	---

Seal

07	NBR seal	M
	FKM seal	V
	EPDM seal	E

¹⁾ Only with FKM or EPDM seal

Order example:

2.0100 PWR10-A00-0-M

Material no. R928006755

For detailed information on Rexroth filter elements, see data sheet 51420.

Spare parts ordering codes

Filter element

Preferred replacement filter element program

3-micron replacement filter element		6-micron replacement filter element		10-micron replacement filter element	
R928006645	2.0040 PWR3-A00-0-M	R928006646	2.0040 PWR6-A00-0-M	R928006647	2.0040 PWR10-A00-0-M
R928006699	2.0063 PWR3-A00-0-M	R928006700	2.0063 PWR6-A00-0-M	R928006701	2.0063 PWR10-A00-0-M
R928006753	2.0100 PWR3-A00-0-M	R928006754	2.0100 PWR6-A00-0-M	R928006755	2.0100 PWR10-A00-0-M
R928006807	2.0160 PWR3-A00-0-M	R928006808	2.0160 PWR6-A00-0-M	R928006809	2.0160 PWR10-A00-0-M
R928006861	2.0250 PWR3-A00-0-M	R928006862	2.0250 PWR6-A00-0-M	R928006863	2.0250 PWR10-A00-0-M
R928006915	2.0400 PWR3-A00-0-M	R928006916	2.0400 PWR6-A00-0-M	R928006917	2.0400 PWR10-A00-0-M
R928006969	2.0630 PWR3-A00-0-M	R928006970	2.0630 PWR6-A00-0-M	R928006971	2.0630 PWR10-A00-0-M
R928007023	2.1000 PWR3-A00-0-M	R928007024	2.1000 PWR6-A00-0-M	R928007025	2.1000 PWR10-A00-0-M

Mechanical visual maintenance indicator

01	02	03	04	05	06
W	O	-	D01	-	-

01	Maintenance indicator	W
02	Mechanical visual indicator	O

Version

03	Pressure differential, modular design	D01
----	---------------------------------------	------------

Switching pressure

04	2.2 bar [32 psi]	2.2
	5.0 bar [72.5 psi]	5.0

Seal

05	EPDM seal	E¹⁾
	NBR seal	M
	FKM seal	V

Max. operating pressure

06	Switching pressure of 2.2 bar [31.9 psi]: 160 bar [2,320 psi]	160
	Switching pressure of 5.0 bar [72.5 psi]: 450 bar [6,527 psi]	450
	Switching pressure of 8.0 bar [116 psi]: 450 bar [6,527 psi]	450

¹⁾ Only with a switching pressure of 5.0 bar

Mechanical visual maintenance indicator

Material no.	Description
R928038785	WO-D01-8.0-M-450
R901025313	WO-D01-5.0-M-450
R901025312	WO-D01-2.2-M-160
R928038784	WO-D01-8.0-V-450
R901066235	WO-D01-5.0-V-450
R901066233	WO-D01-2.2-V-160
R928054248	WO-D01-5.0-E-450

Spare parts ordering codes

Seal kit

01	02	03	04
D	350/445LE		-

01	Seal kit	D
02	Series	350/445LE

Size

03	Sizes 0040-0100	N0040-0100
	Sizes 0130-0150	0130-0150
	Sizes 0160-0400	N0160-0400
	Size 0630	N0630
	Size 1000	N1000

Seal

04	NBR seal	M
	FKM seal	V
	EPDM seal	E

Seal kit

Material no.	Description
R928028527	D350/445LEN0040-0100-M
R928028530	D350LE0130-0150-M
R928028532	D350/445LEN0160-0400-M
R928028536	D350/445LEN0630-M
R928028537	D350/445LEN1000-M
R928028528	D350/445LEN0040-0100-V
R928028531	D350LE0130-0150-V
R928028533	D350/445LEN0160-0400-V
R928028529	D350/445LEN0630-V
R928028534	D350/445LEN1000-V
R961010717	D350/445LEN0040-0100-E
R961010716	D350LE0130-0150-E
R961010715	D350/445LEN0160-0400-E
R961010714	D350/445LEN0630-E
R961010713	D350/445LEN1000-E

Assembly, commissioning, maintenance

Assembly

- ▶ The max. operating pressure of the system cannot exceed the max. admissible operating pressure of the filter (see name plate).
- ▶ When assembling the filter (see also “Tightening torques”), note the flow direction (arrows) and the required servicing height of the filter element (see “Dimensions”).
- ▶ Filter element exchange is made easiest when the filter bowl is oriented downward. Ensure the maintenance indicator is easily visible.
- ▶ Remove the plastic plugs in the filter inlet and outlet.
- ▶ Make sure power is disconnected during assembly.
- ▶ The optional electrical maintenance indicator is connected using the electronic switching element with 1 or 2 switching points, which is placed on the mechanical visual maintenance indicator and held in place by a locking ring.

Commissioning

- ▶ Commission the system.



Important:

The filter has no bleeding mechanism.

Maintenance

- ▶ If the red indicator pin rises out of the mechanical visual maintenance indicator and/or the electronic switching element switches at operating temperature,

the filter element is dirty and has to be replaced/ cleaned. For more details, see data sheet 51420.

- ▶ The material number of the correct replacement filter element is on the name plate of the complete filter. Verify that it matches the material number on the filter element.
- ▶ Decommission the system.
- ▶ Release operating pressure on the system side.



Important:

The filter has no bleeding mechanism.

- ▶ Drain the oil on the dirt side using the drain screw (size 0160 and larger).
- ▶ Unscrew the filter bowl (or base if size 1000).
- ▶ Slightly turn the filter element to remove it from the spigot.
- ▶ Clean the filter components as needed.
- ▶ Check the seals on the filter bowl for damage and replace them as needed.
For compatible seal kits, see “Spare parts”.
- ▶ Wire mesh filter elements can be cleaned. For detailed cleaning instructions, see data sheet 51420.
- ▶ Slightly turn the new or cleaned filter element to install it on the spigot.
- ▶ Assembly is reverse of removal.
- ▶ Note the torque specifications (“Tightening torques”).
- ▶ Commission the system.

⚠ WARNING

- | | |
|---|---|
| <ul style="list-style-type: none"> ▶ Only install or remove when system is not pressurized. ▶ Filter is pressurized. ▶ Only remove filter bowl when it is not pressurized. ▶ Do not replace maintenance indicator when filter is pressurized. | <ul style="list-style-type: none"> ▶ Failure to observe flow of direction during assembly will cause filter element to be damaged beyond repair. Particles will enter the system and damage downstream components. |
|---|---|



Important:

- ▶ Only trained specialists may work on the filter.
- ▶ The safety and functionality of the filter are only guaranteed with original Bosch Rexroth spare parts.
- ▶ The warranty will be void if the delivery item is

modified or improperly mounted, installed, maintained, repaired or used by the ordering party or a third party, or exposed to environmental conditions exceeding our installation conditions.

Tightening torques

Mounting

Series 350...		LEN0040	LEN0063	LEN0100	LE0130	LE0150	LEN0160	LEN0250	LEN0400	LEN0630	LEN1000
Screw/tightening torque when $\mu_{\text{total}} = 0.14$	Nm [lb-ft]	M6/4.5 [3.3] ± 10%				M8/10.5 [7.7] ± 10%			M12/37 [27.3] ± 10%		
Quantity		4									
Recommended screw property class		8.8									
Min. screw-in depth	mm [inch]	6 [0.24] + 1 [0.04]					10 [0.4] + 2 [0.08]				

Filter bowl and maintenance indicator

Series 350...		LEN0040	LEN0063	LEN0100	LE0130	LE0150	LEN0160	LEN0250	LEN0400	LEN0630	LEN1000
Filter bowl		Screw in filter bowl as far as it will go, then unscrew 1/8 to 1/2 turn									
Maintenance indicator	Nm [lb-ft]	Max. 50 [36.9]									
EN 175301-803 switching element cubic connector screw	Nm [lb-ft]	M3/0.5 [3.7]									

Directives and standardization

Product validation

Rexroth filters, the filter elements built into them and filter accessories are tested and quality-monitored according to different ISO test standards:

Pressure pulse test	ISO 10771:2015-08
Filtration performance test (multipass test)	ISO 16889:2008-06
Δp (pressure loss) characteristic curves	ISO 3968:2001-12
Compatibility with hydraulic fluid	ISO 2943:1998-11
Collapse pressure test	ISO 2941:2009-04

The development, manufacture and assembly of Rexroth industrial filters and Rexroth filter elements is carried out within the framework of a certified quality management system in accordance with ISO 9001:2000.

Classification according to the Pressure Equipment Directive

Inline filters for hydraulic applications as per 51422 are considered pressure holding equipment under Article 1 Section 2.1.4 Pressure Equipment Directive 97/23/EC (PED). However, under Article 1 Section 3.6 PED, hydraulic filters are exempt from the PED if they are not classified

higher than Category I (Guideline 1/19).

The fluids from "Compatibility with permitted hydraulic fluids" were considered for the classification.

They do not receive a CE mark.

Use in explosive areas as per Directive 94/9/EC (ATEX)

Inline filters as per 51422 are not equipment or components in terms of Directive 94/9/EC and do not receive a CE mark. The ignition risk analysis showed that these inline filters do not have their own ignition sources as per DIN EN 13463-1:2009.

DIN EN 60079-14:2012 – be used in intrinsically safe electric circuits (Ex ib) in systems without requiring marking and certification.

Inline filters and the electronic maintenance indicators described here can be used in the following explosive areas:

According to DIN EN 60079-11:2012, electronic maintenance indicators with a switching point:

WE-1SP-M12x1 **R928028409**

WE-1SP-EN175301-803 **R928036318**

are considered simple electronic operating equipment that does not have its own voltage source. This simple electronic operating equipment may – according to

	Zone suitability	
Gas	1	2
Dust	21	22

Directives and standardization

Complete filter with mech. visual maintenance indicator				
Use/classification			Gas 2G	Dust 2D
Classification			Ex II 2G c IIC TX	Ex II 2D c IIC TX
Medium conductivity	pS/m	min.	300	
Dust accumulation		max.	-	0.5 mm

Electronic switching element in intrinsically safe electric circuit				
Use/classification			Gas 2G	Dust 2D
Classification			Ex II 2G Ex ib IIB T4 Gb	Ex II 2D Ex ib IIIC T100 °C Db
Admissible intrinsically safe electric circuits			Ex ib IIC, Ex ic IIC	Ex ib IIIC
Technical data			Values only for intrinsically safe electric circuit	
Switching voltage	V_i	max.	150 V AC/DC	
Switching current	I_i	max.	1.0 A	
Switching power	P_i	max.	1.3 W T4 T_{max} 40 °C	750 mW T_{max} 40 °C
		max.	1.0 W T4 T_{max} 80 °C	550 mW T_{max} 100 °C
Surface temperature ¹⁾		max.	-	100 °C
Inner capacitance	C_i			Negligible
Inner inductance	L_i			Negligible
Dust accumulation		max.	-	0.5 mm

¹⁾ Temperature is based on the temperature of the medium in the filter and cannot exceed this value.

Possible circuit as per DIN EN 60079-14

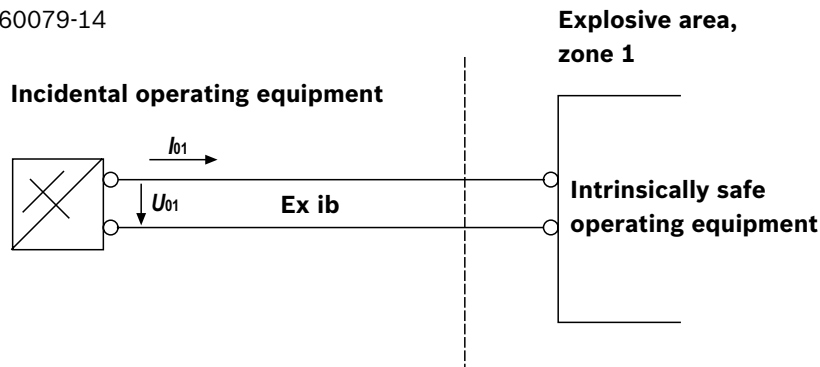

⚠ WARNING	
<ul style="list-style-type: none"> ▶ Explosion hazard due to high temperature. Temperature is based on temperature of medium in hydraulic circuit and cannot exceed this value. Take steps to make sure max. admissible ignition temperature is not exceeded in explosive area. ▶ Make sure potential equalization is sufficient when using 51422 inline filters in explosive areas. Ground- 	<ul style="list-style-type: none"> ing the filter with mounting screws is recommended. Note that paint and oxide protective coating are not electrically conductive. ▶ When replacing filter element, remove packaging material from explosive area around replacement element.

👉 Important:

- ▶ Safety and functionality of the filter are only guaranteed with original Bosch Rexroth spare parts.

- ▶ Maintenance may only be performed by specialists on instruction of the owner in accordance with Directive 1999/92/EC Annex II Section 1.1.

Notes

Bosch Rexroth AG
Ketsch plant
Hardtwaldstrasse 43
68775 Ketsch, Germany
Phone +49 (0) 62 02 / 6 03-0
filter-support@boschrexroth.de
www.boschrexroth.com

© This document, as well as the data, specifications and other information contained therein, are the exclusive property of Bosch Rexroth AG. It may not be reproduced or given to third parties without our consent.
This information only serves to describe the product. It cannot be used to derive statements concerning a certain condition or suitability for a certain application. This information also does not release the user from exercising his/her own judgment and conducting his/her own testing.
Our products are subject to a natural process of wear and aging.