

Duplex filter

RE 51410/02.20
Replaces: 02.09

1/15

Types 16 FD 2500 to 7500

Nominal sizes according to BRFS: 2500 to 7500
 Nominal pressures 16 bar
 Connections up to DN 300
 Operating temperature $-10\text{ }^{\circ}\text{C}$ to $+90\text{ }^{\circ}\text{C}$



H7724_d

Table of contents

Contents	Page
Application, features	1
Design, filter element, accessories, characteristic curves, quality and standardization	2
Ordering details	3
Preferred types	4, 5
Ordering details: electronic switching element for clogging indicator	6
Plug-in connectors	6
Filter design	7
Symbols	8
Technical data	9
Unit dimensions	10
Spare parts	11, 12
Directives and standardization	13
Installation, commissioning and maintenance	14

Application

- Filtration of pressure fluids and lubricants.
- Filtration of fluids and gases.
- Direct installation into pipelines.
- Direct wear protection of downstream components and systems.
- Continuous operating mode due to duplex filter design.

Features

- Filters for inline installation
- Extremely large filter area
- Low pressure drop
- Special highly efficient filter media
- Versatile applications

Design

Steel welded construction of two filter housings that are connected with each other as switch unit by means of four shut-off valves. The connections are aligned vertically. Filter cover with bleed and filter housing with drain screws.
Materials as per spare parts list.

Further design variants available on request.

Filter element

Pleated design with optimized pleat density and various filter media.

The filter element is the most important component of the "FILTER" system in view of the prolonged life and the wear protection of the systems.

The most important criteria for selection are the required degree of cleanliness of the operating medium, the initial pressure differential and the contamination retention capacity.

For further detailed information please refer to our brochure "Filter Elements".

Bypass valve

To protect the filter element during startup and over pressurization due to clogging.

Accessories

Clogging indicator

Basically, the filter is equipped with mechanical optical clogging indicator. The electronic clogging indicator is connected via the electronic switching element with 1 or 2 switching points, which has to be ordered separately. The electronic switching element is attached to the mechanical optical clogging indicator and held by means of a locking ring.

Bleed valve

For bleeding the filter in the commissioning and for the safe reduction of the operating pressure.

Characteristic curves

An optimum filter selection is made possible by our "BRFilterSelect" software, see download area <http://www.boschrexroth.com/filter>.

Additional characteristic curves for the filters in this catalogue can be found in the BRFS filter calculation program.

Quality and standardization

The development, manufacture, and assembly of BRFS industrial filters and BRFS filter elements is carried out within the framework of a certified quality management system in accordance with ISO 9001:2000.

The pressure filters for hydraulic applications according to 51410 are pressure holding equipment according to article 1, section 2.1.4 of the pressure equipment directive 97/23/EC (DGRL). However, on the basis of the exception in article 1, section 3.6 of the DGRL, hydraulic filters are exempt from the DGRL if they are not classified higher than category I (guideline 1/19). They do not receive a CE mark.

Ordering details

of the filter

	16	FD		- A	- 0		V2,2-D0	0	
--	-----------	-----------	--	------------	------------	--	----------------	----------	--

Pressure
16 bar = 16

Design
Duplex filter = FD

Nom. size
FD... = 2500 3000 4000 6000 7000 7500

Filtration rating in µm nominal
Stainless steel wire mesh, cleanable:
G10, G25, G40, G100 = G...
Paper, non-cleanable P10 = P...

absolute (ISO 16889)
Micro glass, non-cleanable
PWR3, PWR10, PWR20 = PWR..

Pressure differential
Max. admissible pressure differential of the filter element
30 bar = A

Element model
Standard adhesive T = 100 °C = 0...
Special adhesive T = 200 °C = E...
Standard material = ...0
chemically nickel-plated = ...D¹⁾

Solenoid
without = 0

Complementary details
A = Pressure compensation line (standard)
M = with cover lifting tool
Z²⁾ = Certificate

Material
0 = Standard

Seal
M = NBR seal
V = FKM seal

Connection
D0 = DIN flange

Clogging indicator
V2,2 = clogging indicator, optical state switching pressure 2.2 bar

Bypass valve
0 = without
6 = 3.0 bar standard

Further models, e.g. filter media, connections, are available at request.

Ordering example:
16 FD 3000 PWR10-A00-06V2,2-D0M0A

of the filter element

	2.		- A	-	-	
--	-----------	--	------------	---	---	--

Filter element
Design = 2.

Filter	Filter element	
	Number	Type
2500, 3000	2 x 3	= 0058
4000	2 x 4	= 0059
6000	2 x 6	= 0059
7000, 7500	2 x 10	= 0059

Filtration rating in µm nominal
Stainless steel wire mesh, cleanable:
G10, G25, G40, G100 = G...
Paper, non-cleanable: P10 = P...

absolute (ISO 16889)
Micro glass, non-cleanable: PWR3, PWR10, PWR20 = PWR..

Pressure differential
Max. admissible pressure differential of the filter element
30 bar = A

Seal
M = NBR seal
V = FKM seal

Bypass valve
0 = without
6 = 3.0 bar standard

Element model
0... = Standard adhesive T = 100 °C
...0 = Standard material
...D¹⁾ = chemically nickel-plated

Ordering example:
2.0058 PWR10-A00-6-M

¹⁾ Only in connection with FKM seal.

²⁾ Z = manufacturer's inspection certificate M according to DIN 55350 T18

Preferred types

Duplex filter with bypass, filtration rating 20 µm and nominal pressure 16 bar

Type	Flow in L/min at $v = 30 \text{ mm}^2/\text{s}$ and $\Delta p = 0,5 \text{ bar}$	Material number
16 FD 2500 PWR20-A00-06V2,2-D0M0A	2650	R928001327
16 FD 3000 PWR20-A00-06V2,2-D0M0A	3500	R928001328
16 FD 4000 PWR20-A00-06V2,2-D0M0A	3900	R928001329
16 FD 6000 PWR20-A00-06V2,2-D0M0A	6400	R928001330
16 FD 7000 PWR20-A00-06V2,2-D0M0A	8700	R928001331
16 FD 7500 PWR20-A00-06V2,2-D0M0A	12000	R928001332

Duplex filter with bypass, filtration rating 10 µm and nominal pressure 16 bar

Type	Flow in L/min at $v = 30 \text{ mm}^2/\text{s}$ and $\Delta p = 0,5 \text{ bar}$	Material number
16 FD 2500 PWR10-A00-06V2,2-D0M0A	2200	R928001321
16 FD 3000 PWR10-A00-06V2,2-D0M0A	2700	R928001322
16 FD 4000 PWR10-A00-06V2,2-D0M0A	3400	R928001323
16 FD 6000 PWR10-A00-06V2,2-D0M0A	5500	R928001324
16 FD 7000 PWR10-A00-06V2,2-D0M0A	7400	R928001325
16 FD 7500 PWR10-A00-06V2,2-D0M0A	10500	R928001326

Duplex filter with bypass, filtration rating 3 µm and nominal pressure 16 bar

Type	Flow in L/min at $v = 30 \text{ mm}^2/\text{s}$ and $\Delta p = 0,5 \text{ bar}$	Material number
16 FD 2500 PWR3-A00-06V2,2-D0M0A	1360	R928001315
16 FD 3000 PWR3-A00-06V2,2-D0M0A	1465	R928001316
16 FD 4000 PWR3-A00-06V2,2-D0M0A	2055	R928001317
16 FD 6000 PWR3-A00-06V2,2-D0M0A	3200	R928001318
16 FD 7000 PWR3-A00-06V2,2-D0M0A	4950	R928001319
16 FD 7500 PWR3-A00-06V2,2-D0M0A	5500	R928001320

Preferred types

Duplex filter without bypass, filtration rating 20 µm and nominal pressure 16 bar

Type	Flow in L/min at $v = 30 \text{ mm}^2/\text{s}$ and $\Delta p = 0,5 \text{ bar}$	Material number
16 FD 2500 PWR20-A00-00V2,2-D0M0A	2650	R928001309
16 FD 3000 PWR20-A00-00V2,2-D0M0A	3500	R928001310
16 FD 4000 PWR20-A00-00V2,2-D0M0A	3900	R928001311
16 FD 6000 PWR20-A00-00V2,2-D0M0A	6400	R928001312
16 FD 7000 PWR20-A00-00V2,2-D0M0A	8700	R928001313
16 FD 7500 PWR20-A00-00V2,2-D0M0A	12000	R928001314

Duplex filter without bypass, filtration rating 10 µm and nominal pressure 16 bar

Type	Flow in L/min at $v = 30 \text{ mm}^2/\text{s}$ and $\Delta p = 0,5 \text{ bar}$	Material number
16 FD 2500 PWR10-A00-00V2,2-D0M0A	2200	R928001303
16 FD 3000 PWR10-A00-00V2,2-D0M0A	2700	R928001304
16 FD 4000 PWR10-A00-00V2,2-D0M0A	3400	R928001305
16 FD 6000 PWR10-A00-00V2,2-D0M0A	5500	R928001306
16 FD 7000 PWR10-A00-00V2,2-D0M0A	7400	R928001307
16 FD 7500 PWR10-A00-00V2,2-D0M0A	10500	R928001308

Duplex filter without bypass, filtration rating 3 µm and nominal pressure 16 bar

Type	Flow in L/min at $v = 30 \text{ mm}^2/\text{s}$ and $\Delta p = 0,5 \text{ bar}$	Material number
16 FD 2500 PWR3-A00-00V2,2-D0M0A	1360	R928001297
16 FD 3000 PWR3-A00-00V2,2-D0M0A	1465	R928001298
16 FD 4000 PWR3-A00-00V2,2-D0M0A	2055	R928001299
16 FD 6000 PWR3-A00-00V2,2-D0M0A	3200	R928001300
16 FD 7000 PWR3-A00-00V2,2-D0M0A	4950	R928001301
16 FD 7500 PWR3-A00-00V2,2-D0M0A	5500	R928001302

Ordering details: electronic switching element for clogging indicator

ABZ	F	V	-1X/-	-DIN
Rexroth power unit accessories	Filter	Clogging indicator	electronic switching element with 1 switching point (changeover) round plug-in connection M12x1 = E1SP-M12X1	Identification for DIN and SAE models Unit series unit series 10 to 19 (10 to 19; unchanged installation and connection dimensions)
			electronic switching element with 2 switching points (normally open/normally closed), 75%, 100%, round plug-in connection M12x1, 3 LED = E2SP-M12X1	1X =
			electronic switching element with 2 switching points (normally open/normally closed), 75%, 100%, signal suppression until 30 °C round plug-in connection M12x1, 3 LED = E2SPSU-M12X1	-DIN =

Electronic switching element	Material no.
ABZFV-E1SP-M12X1-1X/-DIN	R901025339
ABZFV-E2SP-M12X1-1X/-DIN	R901025340
ABZFV-E2SPSU-M12X1-1X/-DIN	R901025341

Ordering example: Pressure filter with mechanical optical clogging indicator for $p_{nom.} = 16 \text{ bar}$ [230 psi] with bypass valve, nominal size 3000, with filter element 10 μm and electronic switching element M12x1 with 1 switching point for pressure liquid mineral oil HLP according to DIN 51524.

Filter: 16 FD 3000 PWR10-A00-06V2,2-D0M0A

Material number: R928001250

Clogging indicator: ABZFV-E1SP-M12X1-1X/-DIN

Material number: R901025339

Plug-in connectors according to IEC 60947-5-2 (dimensions in mm [inch])

for electronic switching element with round plug-in connection M12x1

Plug-in connector for K24 4-pin, M12x1 with screwed connection, cable fitting Pg9.

Material no. R900031155

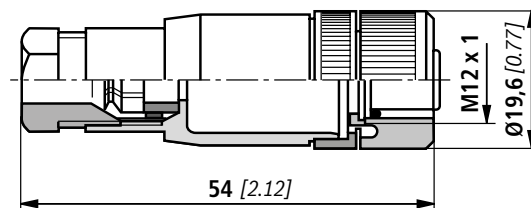

Plug-in connector for K24-3m 4-pin, M12x1 with molded in PVC cable, 3 m long.

Line cross-section: 4 x 0.34 mm²

Core marking:

1	brown
2	white
3	blue
4	black

Material no. R900064381

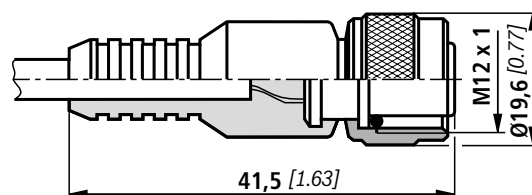

For additional round plug-in connections, see data sheet 08006.

Filter design

Easy selection of the filter size is made possible by the FilterSelect online tool. The filter can be designed using the operating pressure, flow and fluid system parameters. The required filter rating is based on the application, the sensitivity to contamination of the components and the environmental conditions.

The program leads you through the menu on a step-by-step basis.

A documentation of the filter selection can finally be created in the form of a PDF file. This file contains the entered parameters, the designed filter with material number including spare parts, and the pressure loss curves.

Link FilterSelect:

<http://filtersselect.boschrexroth.com/rexfilter/>

Other languages can be selected using the page navigation.

Home Language About us Legal notice www.bosch.com

Rexroth
Bosch Group

www.boschrexroth.com Contact

Bosch Rexroth FilterSelect

standard search

application: hydraulics for industrial use and applications with lubricating oil

Product category: please select

type: please select

pressure range: please select

filter material: please select

fineness: please select

volume flow rate: [] [l/min]

viscosity:
* = working point

kin viscosity 1: 32 [mm²/s]

search via type of medium full-text search medium

please select

please select

temp 1: [] [°C] [] [°F] kin viscosity 1: [] [mm²/s]

dyn. Viscosity 1: [] [cP] density 1: [] [kg/dm³] kin viscosity 1: [] [mm²/s]

collapse pressure resistance according to ISO 2941: 30 bar

Start search

Symbols

Pressure filter with bypass and mechanical display

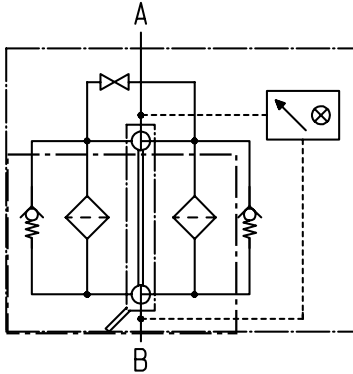

Pressure filter without bypass and mechanical display

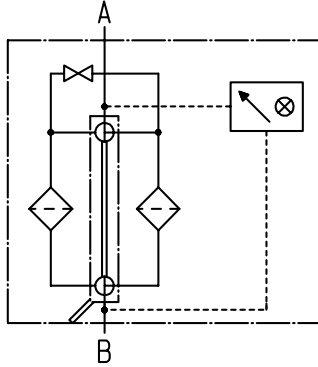

Electronic switching element for clogging indicator

Switching element Plug

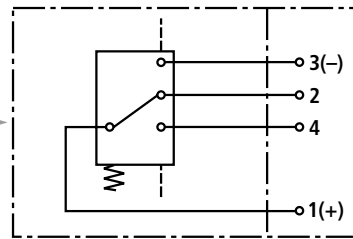

ABZFV-E1SP-M12X1-1X/-DIN

Switching element Plug

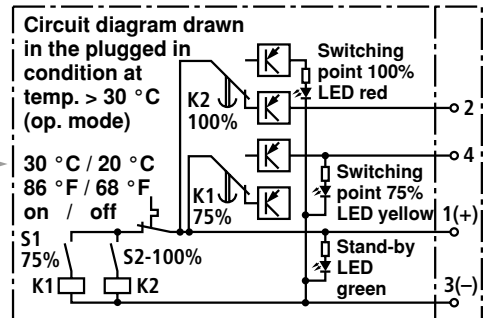

ABZFV-E2SPSU-M12X1-1X/-DIN

Switching element Plug

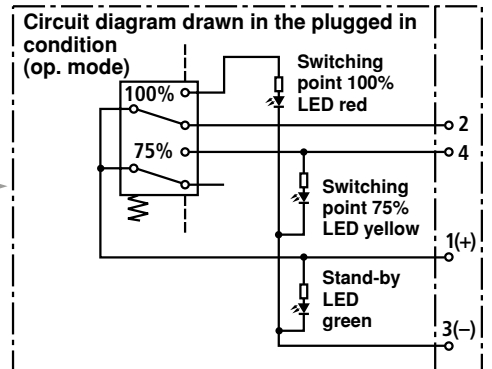

ABZFV-E2SP-M12X1-1X/-DIN

Technical data (for applications outside these parameters, please consult us!)**Electronic** (electric switching element)

Electrical connection		Round plug-in connection M12x1, 4-pin
Contact load, direct voltage	A	Max. 1
Voltage range	E1SP-M12x1 V DC/AC	Max. 150
	E2SP V DC	10 to 30
Max. switching capacity with ohmic loads		20 VA; 20 W; (70 VA)
Switching type	E1SP-M12x1	Changeover
	E2SP-M12x1	Normally open at 75% of the response pressure, Normally closed at 100% of the response pressure
	E2SPSU-M12x1	Normally open at 75% of the response pressure, Normally closed at 100% of the response pressure Signal switching through at 30 °C [86 °F], Return switching at 20 °C [68 °F]
Display via LEDs in the electronic switching element E2SP...		Stand-by (LED green); 75% switching point (LED yellow) 100% switching point (LED red)
Type of protection according to EN 60529		IP 65
For direct voltage above 24 V a spark suppression is to be provided to protect the switching contacts.		
Weight electronic switching element: – with round plug-in connection M12x1	kg [lbs]	0.1 [0.22]

Unit dimensions (dimensions in mm)

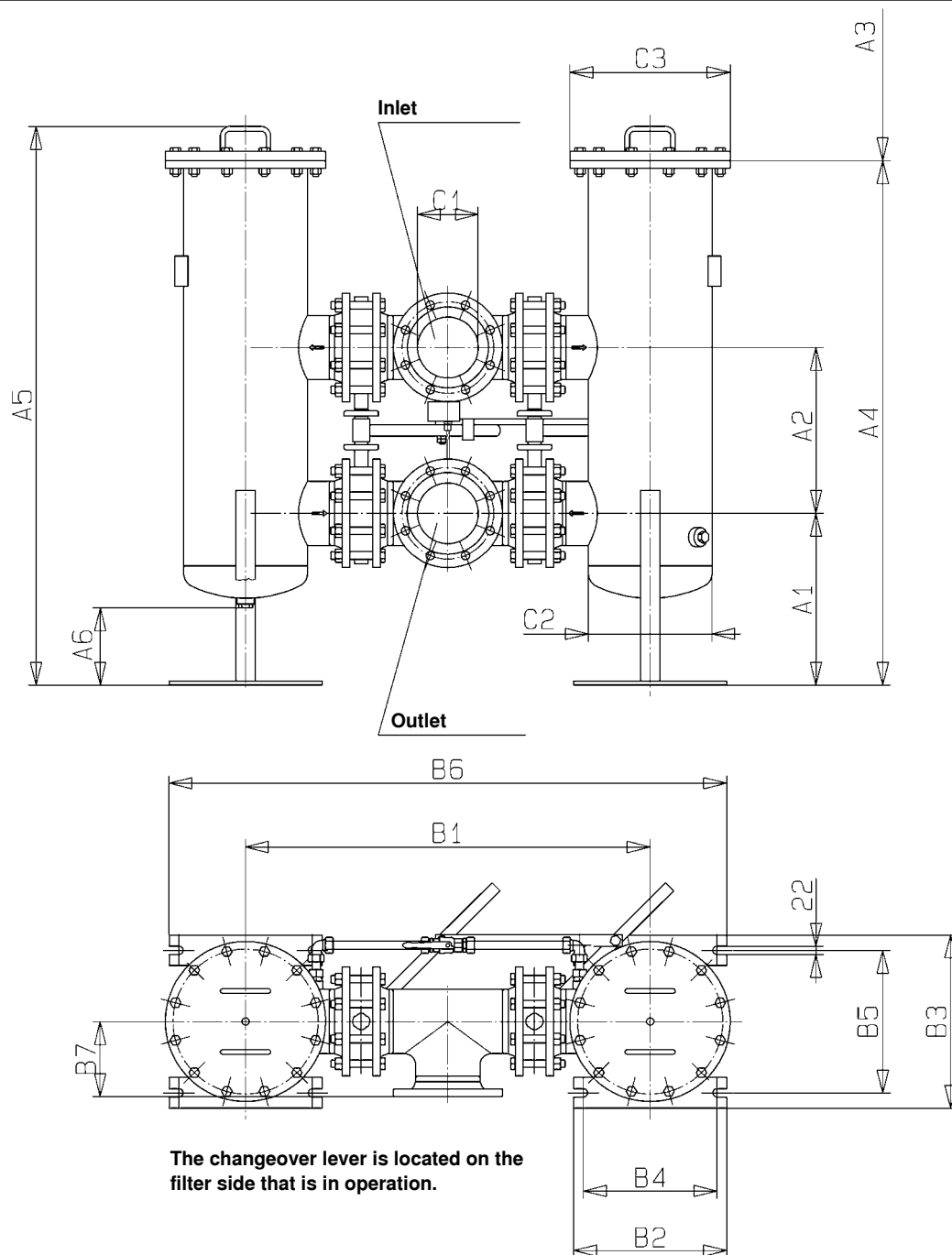

Type 16 FD...	Con- tent in L	Weight in kg ¹⁾	A1	A2	A3 ²⁾	A4	A5	A6	B1	B2	B3	B4	B5	B6	B7	C1	C2	C3
2500	2 x 64	285	500	435	860	1295	1385	257	972	400	403	350	323	1372	180	DN 125	Ø 273	Ø 375
3000	2 x 70	325	500	435	860	1295	1385	257	1010	400	403	350	323	1410	199	DN 150	Ø 273	Ø 375
4000	2 x 99	420	450	435	990	1375	1465	197	1060	400	454	350	374	1460	199	DN 150	Ø 323.9	Ø 420
6000	2 x 178	505	500	480	990	1640	1730	212	1202	400	486	350	406	1602	241	DN 200	Ø 355.6	Ø 445
7000	2 x 395	995	500	585	990	1675	1841	150	1450	400	639	350	559	1850	287	DN 250	Ø 508	Ø 645
7500	2 x 412	1210	500	635	990	1705	1870	114	1642	400	639	350	559	2042	333	DN 300	Ø 508	Ø 645

¹⁾ Weight including standard filter element and clogging indicator.

²⁾ Withdrawal dimension for filter element replacement.

Spare parts

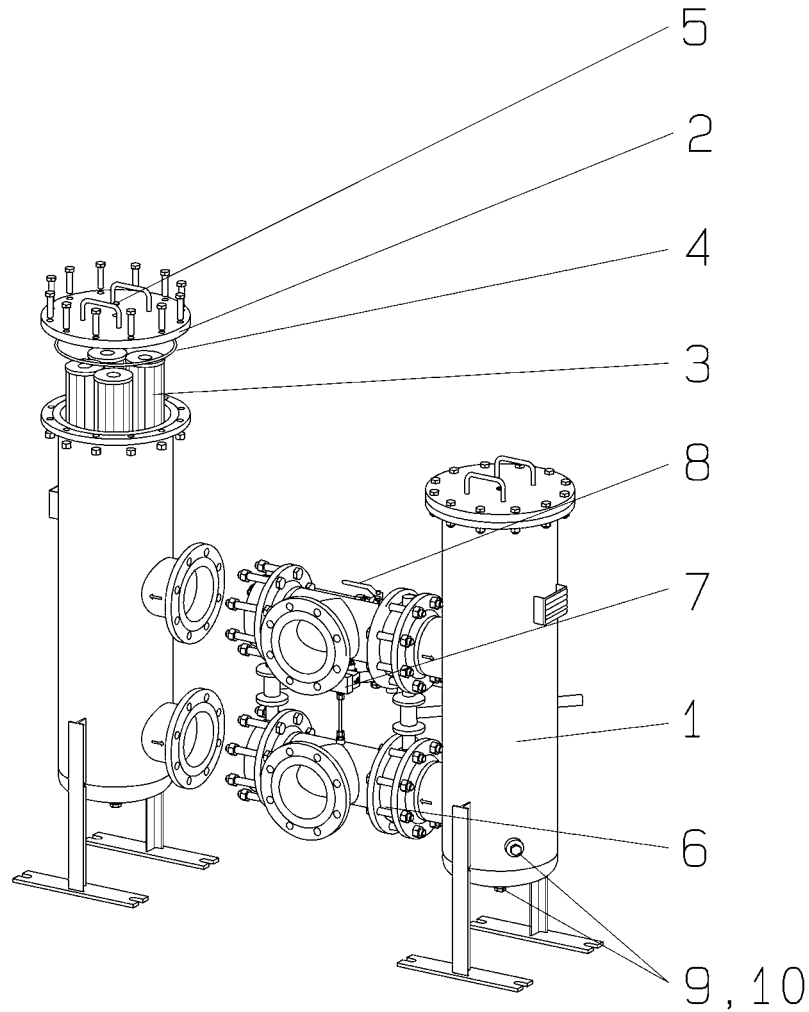

Part	Piece	Description	Material		Ordering information 16FD...					
			Steel	Stainless steel	2500	3000	4000	6000	7000	7500
1	2	Filter housing	Steel	1.4571	Please indicate ordering information "Filter"					
2	2	Filter cover	Steel	1.4571	Please indicate ordering information "Filter"					
3	1	Filter element kit	various	various	Please indicate ordering information "Filter Element"					
					2 x 3 Single elements 2.0058	2 x 4 Single elements 2.0059	2 x 6 Single elements 2.0059	2 x 10 Single elements 2.0059		
3.1	1	Seal ring kit	NBR / FKM		Please indicate ordering information "Filter"					
4	1	Seal ring	NBR / FKM		Please indicate ordering information "Filter"					
5	2	Bleed screw	1.4571 / FKM		Part No. 13284					
6	2	Shut-off valve	various		Please indicate ordering information "Filter"					
7	1	Clogging indicator	various		See ordering information "Clogging indicator"					
8	1	Pressure compensation line	various		Please indicate ordering information "Filter"					
9	4	Plug	5.8	A4	Part no. 791/part no. 3485 for design "Stainless steel"					
10	4	Seal ring	Soft steel	A4	Part no. 335/part no. 3752 for design "Stainless steel"					

All part numbers BRFS specific.

Spare parts (insert for DIN and SAE filters)

Mechanical optical clogging indicator

Rexroth power unit accessories

Filter

Clogging indicator

Mechanical optical clogging indicator for low-pressure filters

Switching point 2.2 bar [32 psi]

= NV2

ABZ	F	V	-	1X	/	-	DIN
-----	---	---	---	----	---	---	-----

DIN =

Identification for DIN and SAE models

M =

V =

Sealing material

see table below

see table below

Unit series

unit series 10 to 19

(10 to 19; unchanged installation and connection dimensions)

1X =

Mechanical optical clogging indicator	Material no.
ABZFV-NV2-1X/M-DIN	R901025312

The ordering details for filter elements can be found in the order details on page 3.

Sealing kits must be ordered by stating the complete part key.

Sealing material and surface coating for pressure fluids

		Ordering detail	
		Sealing material	Element model
Mineral oils			
Mineral oil	HLP according to DIN 51524	M	...0
Fire-resistant hydraulic fluids			
Emulsions	HFA-E according to DIN 24320	M	...0
Synthetic water solutions	HFA-S according to DIN 24320	M	...D
Water solutions	HFC according to VDMA 24317	M	...D
Phosphate esters	HFD-R according to VDMA 24317	V	...D
Organic esters	HFD-U according to VDMA 24317	V	...D
Hydraulic fluids that are fast biodegradable			
Triglycerides (rape seed oil)	HETG according to VDMA 24568	M	...D
Synthetic esters	HEES according to VDMA 24568	V	...D
Polyglycoles	HEPG according to VDMA 24568	V	...D

Directives and standardization

Product validation

Rexroth filters, the filter elements built into them and filter accessories are tested and quality-monitored according to different ISO test standards:

Pressure pulse test	ISO 10771:2015-08
Filtration performance test (multipass test)	ISO 16889:2008-06
Δp (pressure loss) characteristic curves	ISO 3968:2001-12
Compatibility with hydraulic fluid	ISO 2943:1998-11
Collapse pressure test	ISO 2941:2009-04

The development, manufacture and assembly of Rexroth industrial filters and Rexroth filter elements is carried out within the framework of a certified quality management system in accordance with ISO 9001:2000.

Installation, commissioning and maintenance

Installation

Verify operating pressure with name plate information.

Install the filter into the pipe work; when doing so, consider the flow direction and the withdrawal height of the filter elements.

Warning!

Vessel is under pressure!

Assemble and disassemble the filter only when system is depressurized!

Keep the pressure compensation closed if the filter is open!

Do not operate the change over valve when the filter is opened!

Do not replace the clogging indicator and the pressure compensation while the filter is under pressure!

Functional and safety warranty only applicable when using genuine Rexroth spare parts!

Service filter only by trained personnel!

Commissioning

Move the switch lever into the central position in order to fill both filter sides.

Switch on system pump. Pressure compensation is open.

Bleed filter by opening the bleed screw, close when operating fluid vents. Close the pressure compensation.

Switch filter into its operating position. In this connection, the switch lever must be in the stop position. Pressure compensation remains closed.

Maintenance

If at operating temperature, the red indicator pin shows out of the clogging indicator so far that it contacts the plastic cap and/or if the switching process in the electric display is triggered, the filter elements are clogged and need to be replaced or cleaned respectively.

Filter element replacement

Open the pressure compensation. Switch the switch lever over into the opposite direction to the stop to the clean filter side. Close the pressure compensation. At the decommissioned filter, reduce the operating pressure by opening the bleed screw. Lift off the filter cover. Open the plugs at the filter housing and drain the filter.

Remove the filter elements from the lower centering spigots in the filter housing by turning them lightly.

Check the filter housing for cleanliness and clean if necessary.

Replace filter element PWR.. and P10. Clean the filter element with material G... .

Install the cleaned or new filter elements into the filter housing. Check the seal and replace it in case of damage or wear. Re-attach the filter cover. Open the pressure compensation. Bleed filter by opening the bleed screw, close when operating fluid vents. Close the pressure compensation.

Technical modifications reserved!

Notes

Bosch Rexroth Filtration Systems GmbH
Hardtwaldstraße 43, 68775 Ketsch, Germany
POB 1120, 68768 Ketsch, Germany
Phone +49 (0) 62 02 / 6 03-0
Fax +49 (0) 62 02 / 6 03-1 99
brfs-support@boschrexroth.de
www.eppensteiner.de

© This document, as well as the data, specifications and other information set forth in it, are the exclusive property of Bosch Rexroth AG. It may not be reproduced or given to third parties without its consent. The data specified above only serve to describe the product. No statements concerning a certain condition or suitability for a certain application can be derived from our information. The information given does not release the user from the obligation of own judgment and verification. It must be remembered that our products are subject to a natural process of wear and aging.