

# FHB series

Maximum working pressure up to 32 MPa (320 bar) - Flow rate up to 485 l/min





# TYPICAL FILTER SIZING Selection Software

**Step 1** Select "FILTERS"

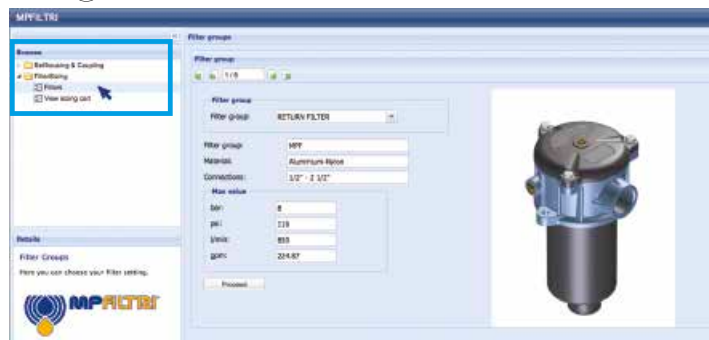

**Step 2** Choose filter group (Return Filter, Pressure Filter, etc.)

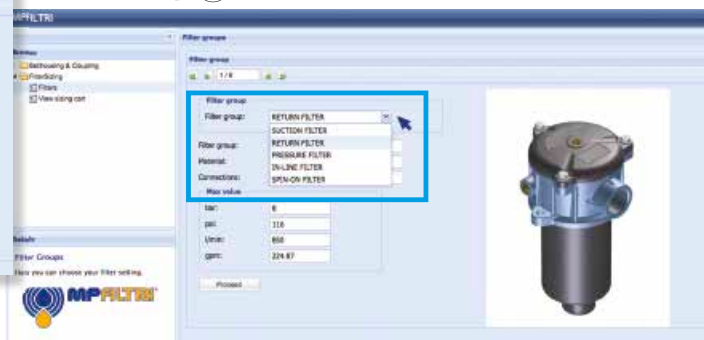

**Step 3** Choose filter type (MPF, MPT, etc.) in function of the max working pressure and the max flow rate



**Step 4** Push "PROCEED"

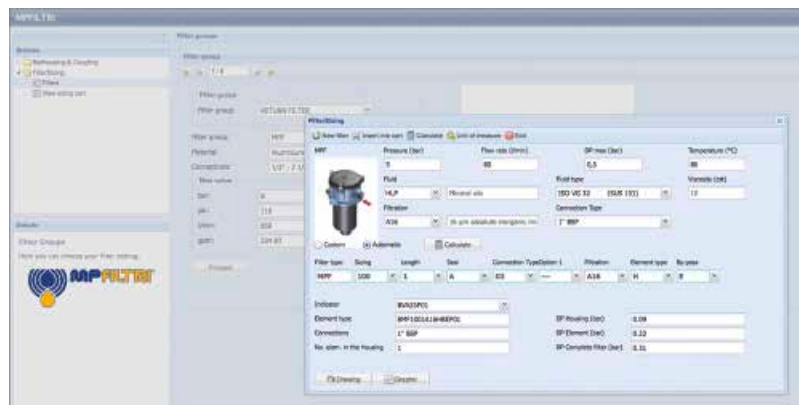
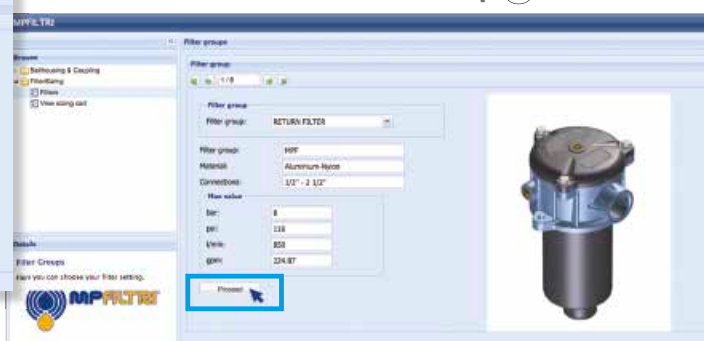

**Step 5**

Insert all application data to calculate the filter size following the sequence:

- working pressure
- working flow rate
- working pressure drop
- working temperature
- fluid material and fluid type
- filtration media
- connection type

**Step 6**

Push "CALCULATE" to have result; in case of any mistake, the system will advice which parameter is out of range to allow to modify/adjust the selection

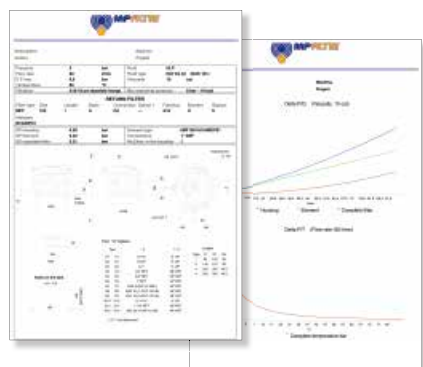

**Step 7**

Download PDF Datasheet "Report.aspx" pushing the button "Drawing"



### High Pressure filters

#### Manifold

**Maximum working pressure up to 32 MPa (320 bar)**

**Flow rate up to 485 l/min**

FHB is a range of high pressure filter for protection of sensitive components in high pressure hydraulic systems in the mobile machines. They are directly connected to the side of the manifold, through the proper flanged interface.

#### Available features:

- Manifold connections up to Ø30 mm, for a maximum flow rate of 485 l/min
- Fine filtration rating, to get a good cleanliness level into the system
- Bypass valve, to relieve excessive pressure drop across the filter media
- Check valve, to protect the system against reverse flow
- Low collapse filter element "N", for use with filters provided with bypass valve
- High collapse filter element "H", for use with filters not provided with bypass valve
- High collapse filter element with external support "S", for filter element protection against the back pressure caused by the check valve in filters not provided with the bypass valve
- Visual, electrical and electronic differential clogging indicators

#### Common applications:

Delivery lines, in any high pressure industrial equipment or mobile machines

#### Filter housing materials

- Head: Phosphatized cast iron
- Housing: Phosphatized steel
- Bypass valve: Steel
- Check valve: Steel

#### Pressure

- Working pressure: 32 MPa (320 bar)
- Test pressure: 48 MPa (480 bar)
- Burst pressure: 96 MPa (960 bar)
- Pulse pressure fatigue test: 1 000 000 cycles with pressure from 0 to 32 MPa (320 bar)

#### Bypass valve

- Opening pressure 600 kPa (6 bar) ±10%
- Other opening pressures on request.

#### Δp element type

- Microfibre filter elements - series N: 20 bar
- Microfibre filter elements - series H: 210 bar (not available for FHB050)
- Microfibre filter elements - series S: 210 bar (only for FHB050)
- Wire mesh filter elements - series N: 20 bar
- Fluid flow through the filter element from OUT to IN

#### Seals

- Standard NBR series A
- Optional FPM series V

#### Temperature

From -25 °C to +110 °C

#### Connections

Manifold mounting

#### Note

FHB filters are provided for vertical mounting



## Weights [kg] and volumes [dm<sup>3</sup>]

Filter series	Weights [kg]					Volumes [dm <sup>3</sup> ]						
	Length	1	2	3	4	5	Length	1	2	3	4	5
<b>FHB 050</b>		2.61	2.98	3.39	3.86	5.04		0.21	0.30	0.40	0.52	0.81
<b>FHB 065</b>		3.33	3.69	4.90	-	-		0.20	0.27	0.49	-	-
<b>FHB 135</b>		6.61	8.21	9.21	-	-		0.40	0.73	0.94	-	-
<b>FHB 320</b>		12.95	15.08	17.37	26.77	-		0.91	1.63	2.40	3.59	-

Filter series	Length	Filter element design - N Series						Filter element design - S Series				
		A03	A06	A10	A16	A25	M25	A03	A06	A10	A16	A25
<b>FHB 050</b>	<b>1</b>	43	42	79	81	101	131	30	40	58	60	74
	<b>2</b>	53	58	84	93	112	132	46	50	76	86	108
	<b>3</b>	67	70	94	101	119	133	59	62	87	95	115
	<b>4</b>	82	87	106	108	122	134	74	80	101	103	119
	<b>5</b>	102	104	119	122	127	136	90	92	105	113	126

Filter series	Length	Filter element design - N Series						Filter element design - H Series				
		A03	A06	A10	A16	A25	M25	A03	A06	A10	A16	A25
<b>FHB 065</b>	<b>1</b>	25	33	55	62	87	133	23	25	49	58	81
	<b>2</b>	33	51	70	76	101	134	33	38	66	75	94
	<b>3</b>	60	71	97	103	118	138	60	68	95	102	116
<b>FHB 135</b>	<b>1</b>	67	72	120	129	177	212	49	55	97	100	160
	<b>2</b>	109	116	152	154	224	250	90	110	137	140	182
	<b>3</b>	153	155	201	205	226	253	126	142	175	187	207
<b>FHB 320</b>	<b>1</b>	130	143	238	286	343	442	110	117	192	201	304
	<b>2</b>	259	281	391	409	454	468	200	230	319	325	392
	<b>3</b>	332	368	441	455	463	476	269	312	381	389	432
	<b>4</b>	368	390	446	462	481	488	311	334	388	394	437

### Maximum flow rate for a complete pressure filter with a pressure drop $\Delta p = 1.5$ bar.

The reference fluid has a kinematic viscosity of 30 mm<sup>2</sup>/s (cSt) and a density of 0.86 kg/dm<sup>3</sup>.

For different pressure drop or fluid viscosity we recommend to use our selection software available on [www.mpfiltri.com](http://www.mpfiltri.com).

You can also calculate the right size using the formulas present on the FILTER SIZING paragraph at the beginning of the full catalogue or at the beginning of the filter family brochure.

Please, contact our Sales Department for further additional information.

### Hydraulic symbols

Filter series	Style S	Style B	Style T	Style D
<b>FHB 050</b>	•	•	•	•
<b>FHB 065</b>	•	•	•	•
<b>FHB 135</b>	•	•	•	•
<b>FHB 320</b>				

--	--	--	--

## Pressure drop

Filter housings  $\Delta p$  pressure drop

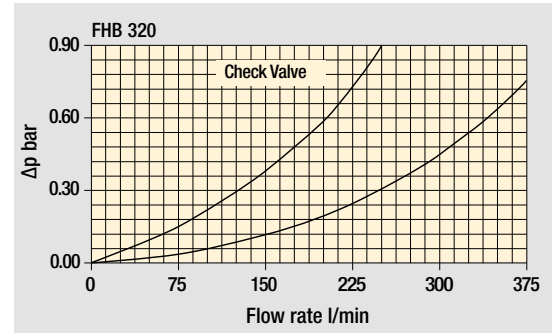
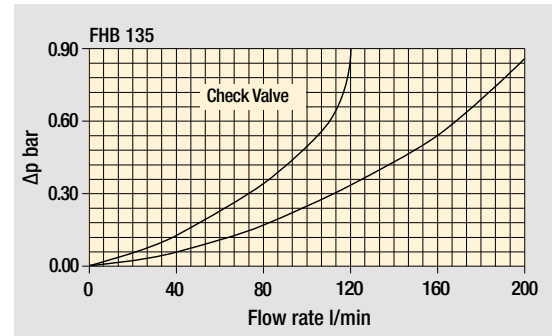
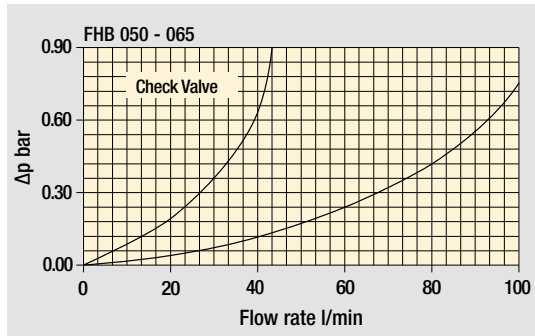

Bypass valve pressure drop

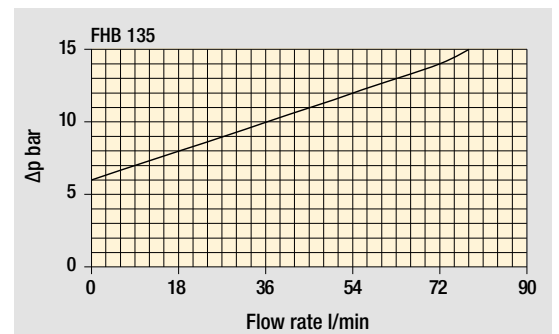
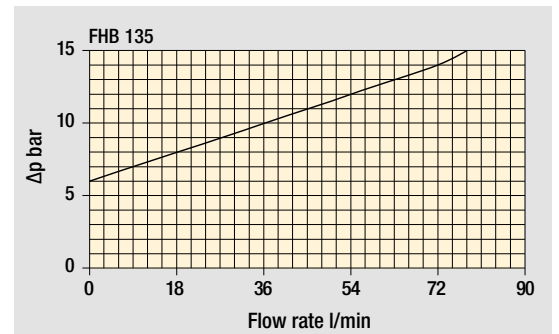
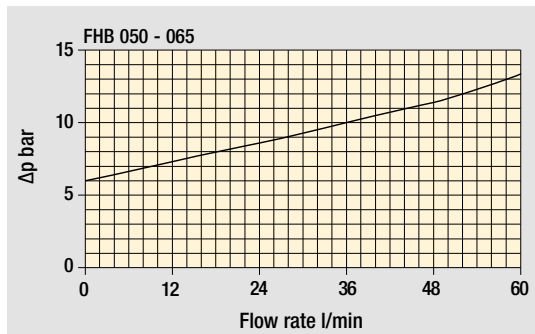

The curves are plotted using mineral oil with density of  $0.86 \text{ kg/dm}^3$  in compliance with ISO 3968.  $\Delta p$  varies proportionally with density.



## Designation & Ordering code

### COMPLETE FILTER

<b>Series and size</b>	Configuration example: <b>FHB050</b>   <b>2</b>   <b>T</b>   <b>A</b>   <b>F1</b>   <b>A06</b>   <b>S</b>   <b>P01</b>							
<b>FHB050</b>								
<b>Length</b>								
<b>1</b>   <b>2</b>   <b>3</b>   <b>4</b>   <b>5</b>								
<b>Valves</b>								
<b>S</b> Without bypass								
<b>B</b> With bypass 6 bar								
<b>T</b> With check valve, without bypass								
<b>D</b> With check valve, with bypass 6 bar								
<b>Seals</b>								
<b>A</b> NBR								
<b>V</b> FPM								
<b>Connections</b>								
<b>F1</b> Manifold								
<b>Filtration rating (filter media)</b>								
<b>A03</b> Inorganic microfiber 3 µm	<b>A16</b> Inorganic microfiber 16 µm							
<b>A06</b> Inorganic microfiber 6 µm	<b>A25</b> Inorganic microfiber 25 µm							
<b>A10</b> Inorganic microfiber 10 µm	<b>M25</b> Wire mesh 25 µm							
		<b>Valves</b>						
<b>Element Δp</b>		<b>S</b>	<b>B</b>	<b>T</b>	<b>D</b>	<b>Execution</b>		
<b>N</b> 20 bar			•		•	<b>P01</b> MP Filtri standard		
<b>S</b> 210 bar		•		•		<b>Pxx</b> Customized		

### FILTER ELEMENT

<b>Element series and size</b>	Configuration example: <b>HP050</b>   <b>2</b>   <b>A06</b>   <b>A</b>   <b>S</b>   <b>P01</b>					
<b>HP050</b>						
<b>Element length</b>						
<b>1</b>   <b>2</b>   <b>3</b>   <b>4</b>   <b>5</b>						
<b>Filtration rating (filter media)</b>						
<b>A03</b> Inorganic microfiber 3 µm	<b>A16</b> Inorganic microfiber 16 µm					
<b>A06</b> Inorganic microfiber 6 µm	<b>A25</b> Inorganic microfiber 25 µm					
<b>A10</b> Inorganic microfiber 10 µm	<b>M25</b> Wire mesh 25 µm					
<b>Seals</b>		<b>Element Δp</b>		<b>Execution</b>		
<b>A</b> NBR	<b>N</b> 20 bar	<b>P01</b> MP Filtri standard				
<b>V</b> FPM	<b>S</b> 210 bar	<b>Pxx</b> Customized				

### ACCESSORIES

<b>Differential indicators</b>		page			page
<b>DEA</b>	Electrical differential indicator	577	<b>DLE</b>	Electrical / visual differential indicator	580
<b>DEH</b>	Hazardous area electronic differential indicator	577-578	<b>DTA</b>	Electronic differential indicator	581
<b>DEM</b>	Electrical differential indicator	578-579	<b>DVA</b>	Visual differential indicator	581
<b>DLA</b>	Electrical / visual differential indicator	579-580	<b>DVM</b>	Visual differential indicator	581
<b>Additional features</b>		page			
<b>T2</b>	Plug	582			



FHB050	
Filter length	H [mm]
1	185
2	222
3	264
4	312
5	434

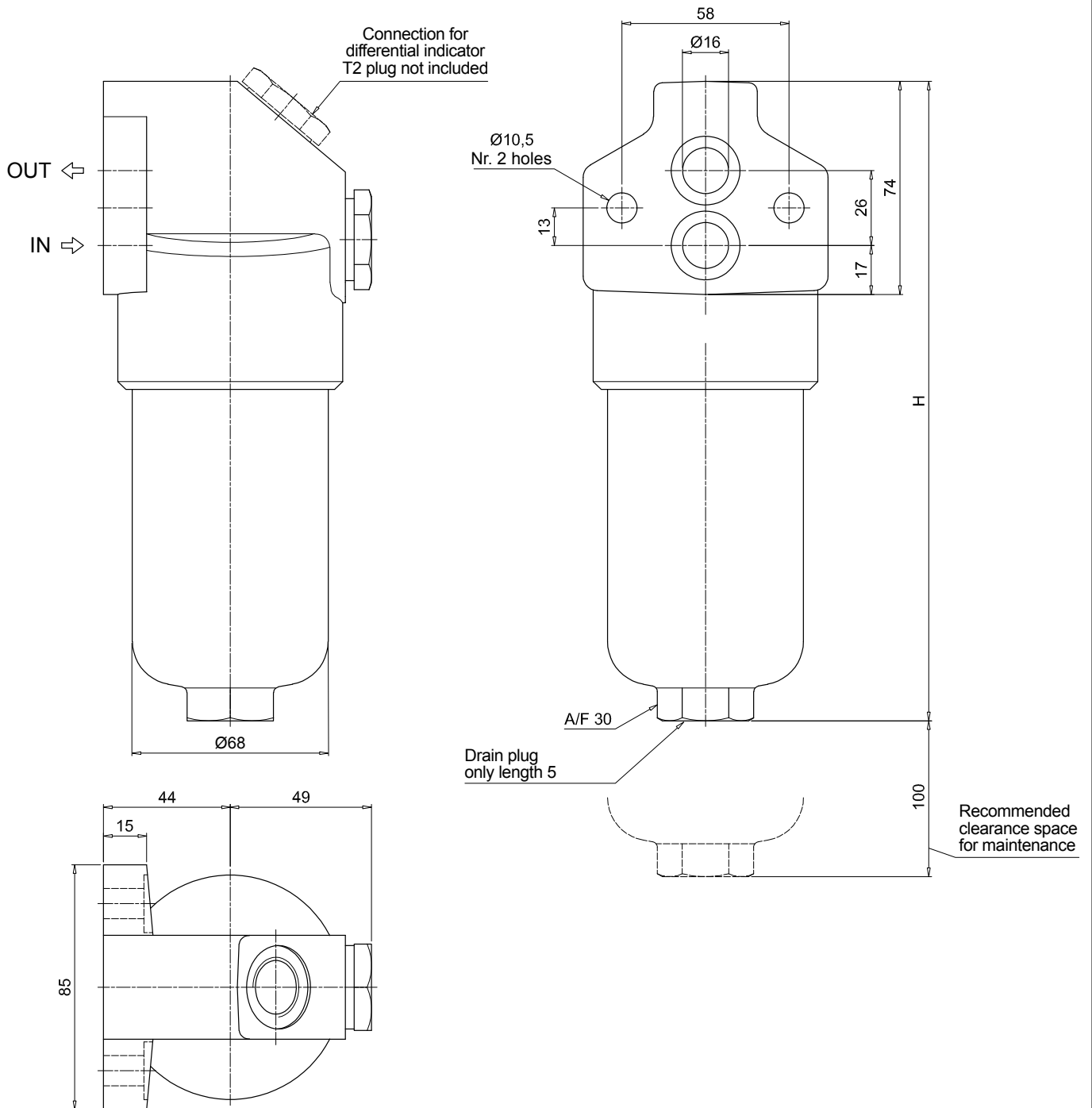

# FHB FHB065 - FHB135 - FHB320

## Designation & Ordering code

### COMPLETE FILTER

<b>Series and size</b>				Configuration example: <b>FHB320</b>   <b>4</b>   <b>S</b>   <b>A</b>   <b>F1</b>   <b>A06</b>   <b>H</b>   <b>P01</b>									
<b>FHB065</b>   <b>FHB135</b>   <b>FHB320</b>													
<b>Length</b>	<b>FHB065</b>	<b>FHB135</b>	<b>FHB320</b>										
<b>1</b>	•	•	•										
<b>2</b>	•	•	•										
<b>3</b>	•	•	•										
<b>4</b>			•										
<b>Valves</b>													
<b>S</b>	Without bypass												
<b>B</b>	With bypass 6 bar												
<b>T</b>	With check valve, without bypass												
<b>D</b>	With check valve, with bypass 6 bar												
<b>Seals</b>													
<b>A</b>	NBR												
<b>V</b>	FPM												
<b>Connections</b>													
<b>F1</b>	Manifold												
<b>Filtration rating (filter media)</b>													
<b>A03</b>	Inorganic microfiber	3 µm	<b>A16</b>	Inorganic microfiber	16 µm								
<b>A06</b>	Inorganic microfiber	6 µm	<b>A25</b>	Inorganic microfiber	25 µm								
<b>A10</b>	Inorganic microfiber	10 µm	<b>M25</b>	Wire mesh	25 µm								
				<b>Element Δp</b>				<b>Valves</b>					
				<b>N</b>	20 bar	<b>S</b>		<b>B</b>	•	<b>T</b>		<b>D</b>	•
				<b>H</b>	210 bar	<b>S</b>	•	<b>B</b>		<b>T</b>	•	<b>D</b>	
				<b>Execution</b>									
				<b>P01</b>	MP Filtri standard	<b>1</b>	•	<b>2</b>	•	<b>3</b>	•	<b>4</b>	•
				<b>P02</b>	Maintenance from the bottom of the housing	<b>1</b>		<b>2</b>		<b>3</b>		<b>4</b>	•
				<b>Pxx</b>	Customized	<b>1</b>		<b>2</b>		<b>3</b>		<b>4</b>	

### FILTER ELEMENT

<b>Element series and size</b>				Configuration example: <b>HP320</b>   <b>4</b>   <b>A06</b>   <b>A</b>   <b>H</b>   <b>P01</b>								
<b>HP065</b>   <b>HP135</b>   <b>HP320</b>												
<b>Element length</b>	<b>HP065</b>	<b>HP135</b>	<b>HP320</b>									
<b>1</b>	•	•	•									
<b>2</b>	•	•	•									
<b>3</b>	•	•	•									
<b>4</b>			•									
<b>Filtration rating (filter media)</b>												
<b>A03</b>	Inorganic microfiber	3 µm	<b>A16</b>	Inorganic microfiber	16 µm							
<b>A06</b>	Inorganic microfiber	6 µm	<b>A25</b>	Inorganic microfiber	25 µm							
<b>A10</b>	Inorganic microfiber	10 µm	<b>M25</b>	Wire mesh	25 µm							
				<b>Seals</b>				<b>Element Δp</b>				
				<b>A</b>	NBR	<b>N</b>	20 bar					
				<b>V</b>	FPM	<b>H</b>	210 bar					
				<b>Execution</b>								
				<b>P01</b>	MP Filtri standard							
				<b>Pxx</b>	Customized							

### ACCESSORIES

<b>Differential indicators</b>		page			page
<b>DEA</b>	Electrical differential indicator	577	<b>DLE</b>	Electrical / visual differential indicator	580
<b>DEH</b>	Hazardous area electronic differential indicator	577-578	<b>DTA</b>	Electronic differential indicator	581
<b>DEM</b>	Electrical differential indicator	578-579	<b>DVA</b>	Visual differential indicator	581
<b>DLA</b>	Electrical / visual differential indicator	579-580	<b>DVM</b>	Visual differential indicator	581
<b>Additional features</b>		page			
<b>T2</b>	Plug	582			

FHB065	
Filter length	H [mm]
<b>1</b>	194
<b>2</b>	225
<b>3</b>	327

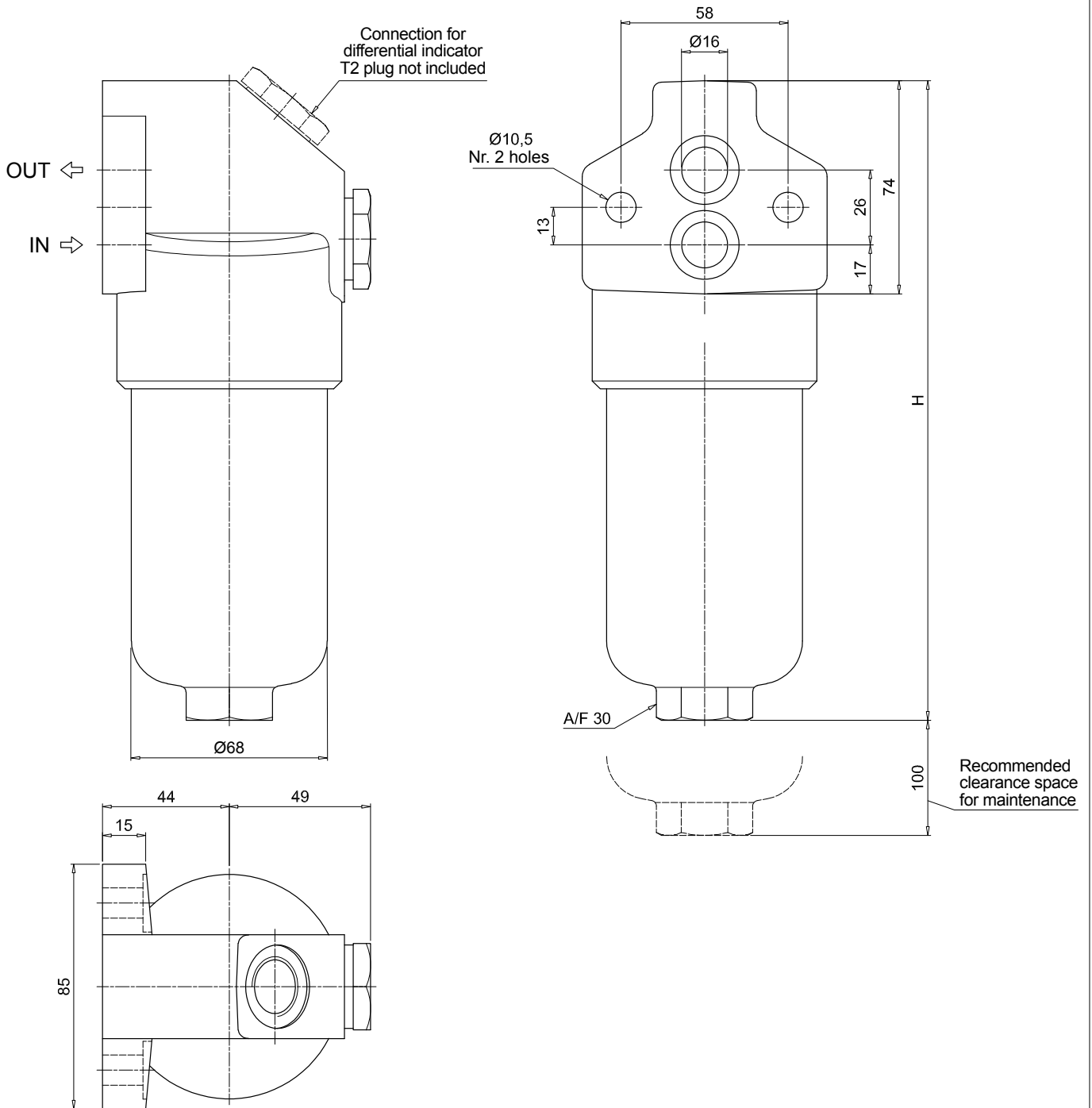

# FHB FHB065 - FHB135 - FHB320

## Dimensions

FHB135

Filter length	H [mm]
<b>1</b>	268
<b>2</b>	381
<b>3</b>	456

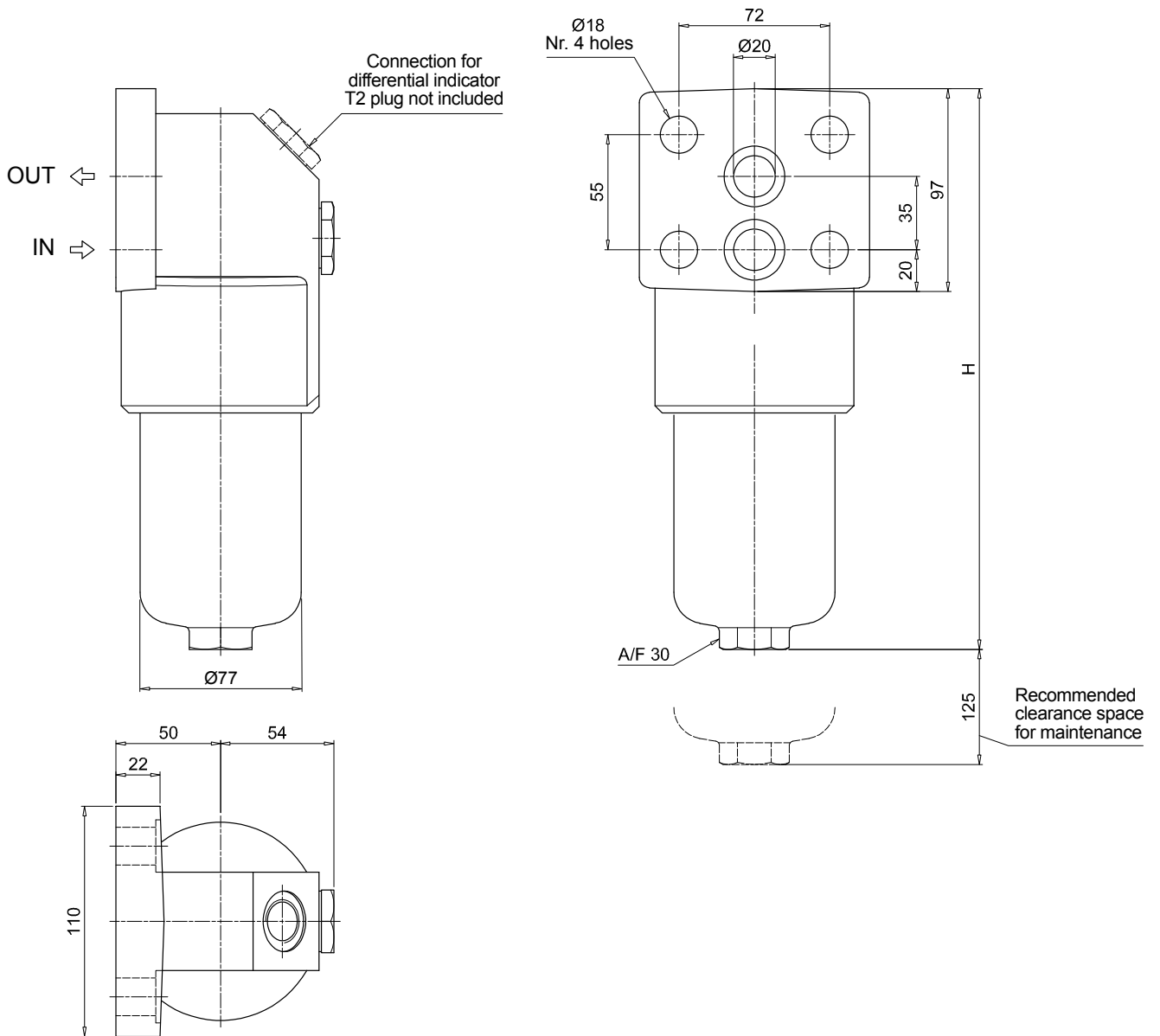

### FHB320

Filter length	H [mm]	H2 [mm]	
		Execution P01	Execution P02
1	301	150	-
2	424	150	-
3	556	150	-
4	709	150	550

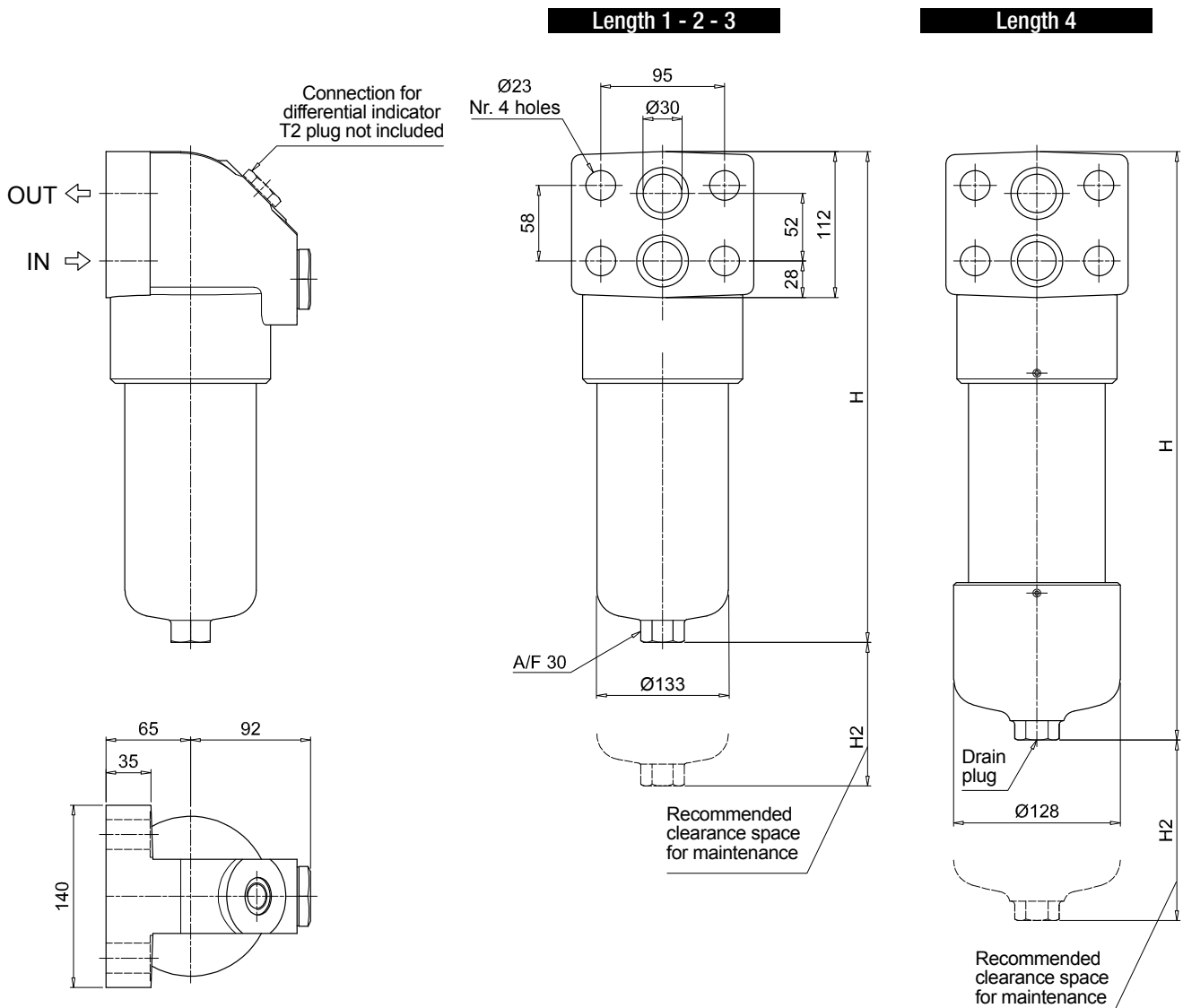

# FHB SPARE PARTS

Order number for spare parts

FHB 050 - 065 - 135 - 320

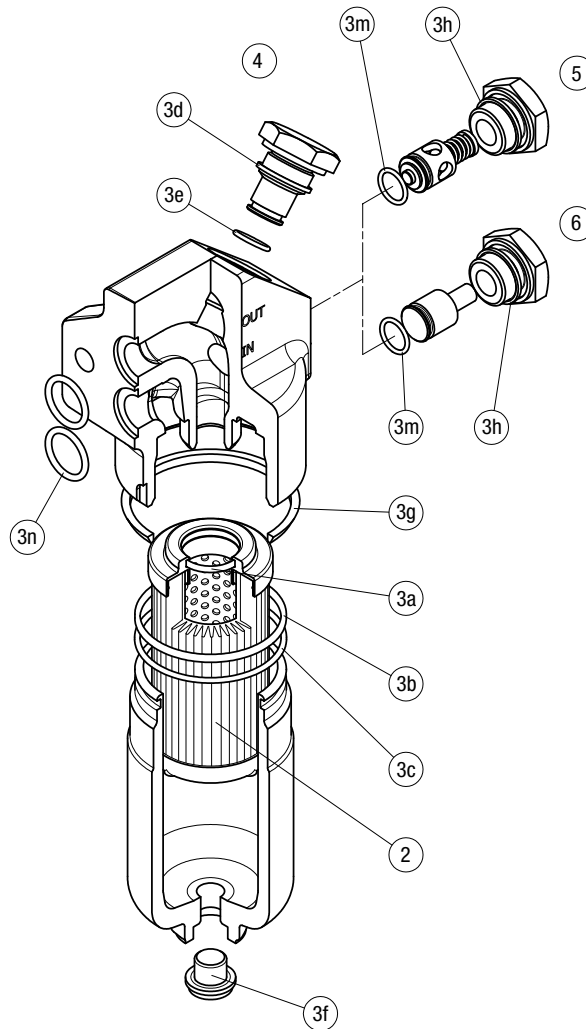

Item:	Q.ty: 1 pc.	Q.ty: 1 pc.		Q.ty: 1 pc.		Q.ty: 1 pc.		Q.ty: 1 pc.	
Filter series	Filter element	Seal Kit code number		Indicator connection plug		Bypass assembly		Non-bypass assembly	
		NBR	FPM	NBR	FPM	NBR	FPM	NBR	FPM
<b>FHB 050</b>	See order table	02050412	02050413	T2H	T2V	02001312	02001385	02001314	02001386
<b>FHB 065</b>		02050266	02050277			02001312	02001385	02001314	02001386
<b>FHB 135</b>		02050270	02050281			02001312	02001385	02001314	02001386
<b>FHB 320</b>		02050273	02050284			02001381	02001382	02001383	02001384