

6/2 ways/positions flow diverters

RE 18302-07/12.09

1/8

L753.... (VS311-VS312-VS315)

Size 10

Series 00

Maximum operating pressure 310 bar [4500 psi]

Maximum flow 140 l/min [36,98 gpm]

Ports G 1/2 -G 3/4 - SAE12



DVI0088

Summary

Description

General specifications

Ordering details

Spool variants

Principles of operation, cross section

Technical data

 Δp - Q_v characteristic curves

External dimensions and fittings

Electric connection

General specifications

Page	
	- 6 way 2 position valve.
1	- Directional spool valve with direct solenoid control.
2	- Upon request, hydraulic / pneumatic pilot , or manual push and twist control.
2	
3	- Control spool operated by screwed-in solenoid, with easily extractable coil fastened by a ring nut.
3	
5	- Wet pin tube for DC coil, with push rod for mechanical override in case of voltage shortage.
6	- Unrestricted 360° orientation of DC coil.
8	- Control spool held in normal position by return spring.
	- Optional manual override (push-button or screw type).
	- Connectors available: DIN 43650 – ISO 4400, AMP Junior, DT04-2P (Deutsch), Free leads.

Ordering details

	L	7	53	_	_	_	_	_	_	0																																																																													
Family Compact directional valve																																																																																							
Type Flow Diverters																																																																																							
Ports G 1/2 DIN 3852 = 4 G 3/4 DIN 3852 = 5 1 1/16-12 UN (SAE12) = E																																																																																							
Control type Solenoid (coil C 65) without emergency = 14 Solenoid (coil C 65) with push-button type emergency = 4P Solenoid (coil C 65) with screw type emergency = 4F Hydraulic / pneumatic control = P1 Manual push and twist control = H1																																																																																							
Spool variants 6 way / 2 position P1 side = 6_																																																																																							
Drain type Internal drain = I External drain = E																																																																																							
	Electric connections 00 = Without coil 01 = With coil, without connector 02 = With coil and with non-assembled connector, type DIN 43650 – ISO 4400 03 = With coil having AMP Junior connector 07 = With coil having DEUTSCH DT 04-2P connect. 31 = With coil and bipolar sheathed lead 350mm [13.8"] long																																																																																						
	Voltage supply Without coil 12V DC 13V DC 24V DC 27V DC 48V DC																																																																																						
	<table border="1" style="border-collapse: collapse;"> <tr> <td style="width: 10%;">00 =</td> <td style="width: 10%;"></td> <td style="width: 10%;"></td> <td style="width: 10%;"></td> <td style="width: 10%;"></td> <td style="width: 10%;"></td> <td style="width: 10%;"></td> <td style="width: 10%;"></td> <td style="width: 10%;"></td> <td style="width: 10%;"></td> <td style="width: 10%;"></td> </tr> <tr> <td>0B =</td> <td style="background-color: #cccccc;"></td> <td style="background-color: #cccccc;"></td> <td style="background-color: #cccccc;"></td> <td style="background-color: #cccccc;"></td> <td style="background-color: #cccccc;"></td> <td style="background-color: #cccccc;"></td> <td style="background-color: #cccccc;"></td> <td style="background-color: #cccccc;"></td> <td style="background-color: #cccccc;"></td> <td style="background-color: #cccccc;"></td> </tr> <tr> <td>AD =</td> <td style="background-color: #cccccc;"></td> <td style="background-color: #cccccc;"></td> <td style="background-color: #cccccc;"></td> <td style="background-color: #cccccc;"></td> <td style="background-color: #cccccc;"></td> <td style="background-color: #cccccc;"></td> <td style="background-color: #cccccc;"></td> <td style="background-color: #cccccc;"></td> <td style="background-color: #cccccc;"></td> <td style="background-color: #cccccc;"></td> </tr> <tr> <td>OC =</td> <td style="background-color: #cccccc;"></td> <td style="background-color: #cccccc;"></td> <td style="background-color: #cccccc;"></td> <td style="background-color: #cccccc;"></td> <td style="background-color: #cccccc;"></td> <td style="background-color: #cccccc;"></td> <td style="background-color: #cccccc;"></td> <td style="background-color: #cccccc;"></td> <td style="background-color: #cccccc;"></td> <td style="background-color: #cccccc;"></td> </tr> <tr> <td>AC =</td> <td style="background-color: #cccccc;"></td> <td style="background-color: #cccccc;"></td> <td style="background-color: #cccccc;"></td> <td style="background-color: #cccccc;"></td> <td style="background-color: #cccccc;"></td> <td style="background-color: #cccccc;"></td> <td style="background-color: #cccccc;"></td> <td style="background-color: #cccccc;"></td> <td style="background-color: #cccccc;"></td> <td style="background-color: #cccccc;"></td> </tr> <tr> <td>OD =</td> <td style="background-color: #cccccc;"></td> <td style="background-color: #cccccc;"></td> <td style="background-color: #cccccc;"></td> <td style="background-color: #cccccc;"></td> <td style="background-color: #cccccc;"></td> <td style="background-color: #cccccc;"></td> <td style="background-color: #cccccc;"></td> <td style="background-color: #cccccc;"></td> <td style="background-color: #cccccc;"></td> <td style="background-color: #cccccc;"></td> </tr> <tr> <td></td> <td style="text-align: center;">31</td> <td style="text-align: center;">07</td> <td style="text-align: center;">03</td> <td style="text-align: center;">02</td> <td style="text-align: center;">01</td> <td style="text-align: center;">00</td> <td colspan="4"></td> </tr> </table> <p style="text-align: center;">Available connections</p>										00 =											0B =											AD =											OC =											AC =											OD =												31	07	03	02	01	00				
00 =																																																																																							
0B =																																																																																							
AD =																																																																																							
OC =																																																																																							
AC =																																																																																							
OD =																																																																																							
	31	07	03	02	01	00																																																																																	

Spool variants

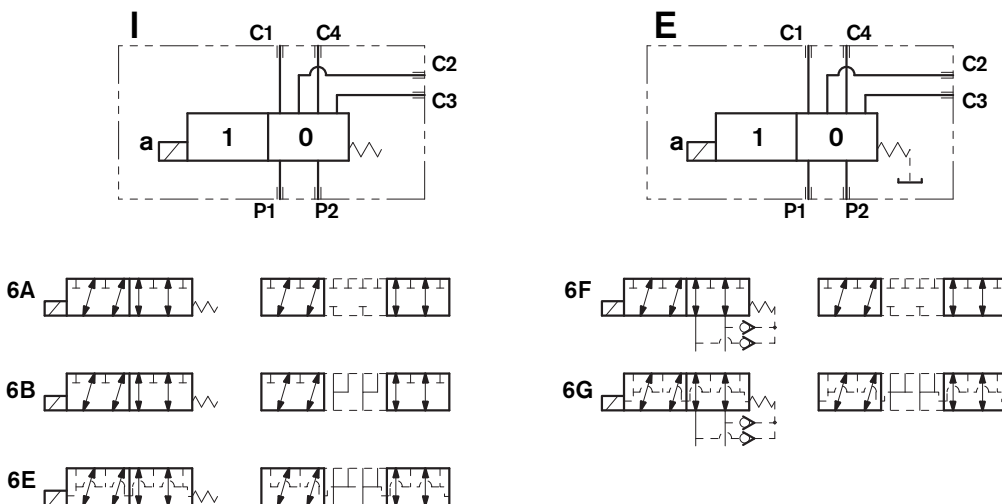

Principles of operation, cross section

A valve basically consists of a housing (1), a control spool (2), a return spring (3) and a solenoid (5). It is designed to connect two inlet lines P1 – P2 (normally a set of hoses) and divert them to either the outlet ports (C1 – C4) with spool in position "0", when the solenoid is de-energized, or to the outlet ports (C2 – C3) with spool in position "1", when the solenoid is energized.

With the coil de-energized, the return spring (3) pushes back the spool (2) and holds it in position "0"

The coil (5) is fastened to the tube by the ring nut (6).

The manual override (6) allows to shift the spool (2) also in case of voltage shortage.

An external drain, to be connected to tank, ensures shifting operations also at higher working pressure.

Hydraulic / pneumatic pilot control for spool shifting is available upon request.

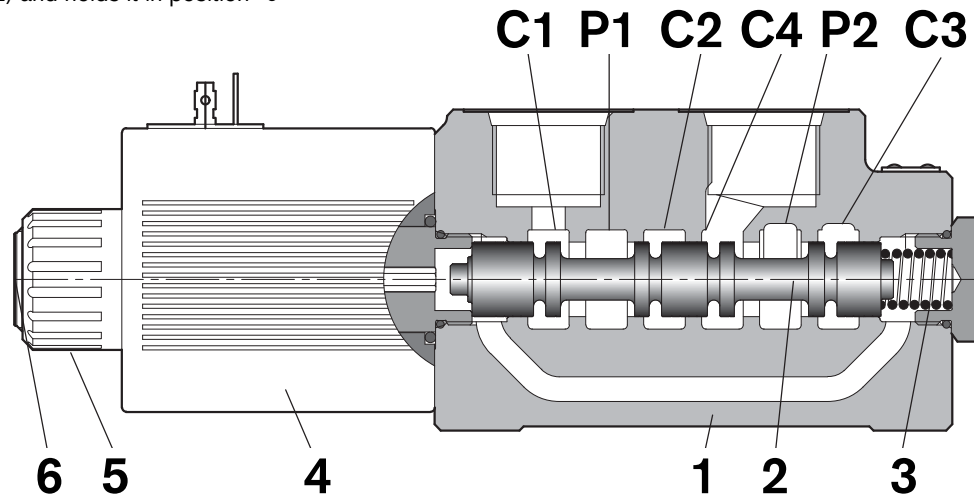

Technical Data (for applications with different specifications consult us)

General

Valve weight	kg [lbs]	5.1 [11.2]
Mounting position		unrestricted
Ambient Temperature	°C [°F]	-20....+50 [-4....+122] (NBR seals)

Hydraulic

Maximum pressure with external drain	bar [psi]	310 [4500]
Maximum pressure with internal drain	bar [psi]	250 [3625]
Maximum pressure with schemes 6F and 6G	bar [psi]	310 [4500]
Maximum flow	l/min [gpm]	140 [36.98]
Pilot pressure needed for hydraulic / pneumatic control	bar [psi]	max 200 [2900] - min 4 [58] with external drain. For versions with internal drain, the pilot pressure required should be at least 11 times higher than inlet pressure (ratio 11:1).
Hydraulic fluid		Mineral oil based hydraulic fluids HL (DIN 51524 part 1). Mineral oil based hydraulic fluids HLP (DIN 51524 part 2). For use of environmentally acceptable fluids (vegetable or polyglycol base) please consult us.
Fluid Temperature	°C [°F]	-20....+80 [-4....+176] (NBR seals)
Permissible degree of fluid contamination		ISO 4572: $\beta_x \geq 75$ X=12...15 ISO 4406: class 20/18/15 NAS 1638: class 9
Viscosity range	mm ² /s	5...420
Internal leakage with 100 bar [1450 psi] secondary pressure at C	cc/min [in ³ /min]	min. 15 [0.9] - max. 40 [2.4]

Electrical

Voltage type	DC										
Voltage tolerance (nominal voltage)	%	-10 ... +10									
Duty	%	Continuous, with ambient temperature $\leq 50^{\circ}\text{C}$ [122°F]									
Maximum coil temperature	$^{\circ}\text{C}$ [°F]	150 [302]									
Insulation class	H										
Compliance with	Low Voltage Directive LVD 73/23/EC (2006/95/EC), 2004/108/EC										
Coil weight with DIN 43650 – ISO 4400 connector	kg [lbs]	1.05 [2.3]									
Voltage	V	12	13	24	27	48					
Voltage type		DC	DC	DC	DC	DC					
Power consumption	W	44	44	44	44	44					
Current ⁽¹⁾	A	3.6	3.4	1.8	1.60	0.90					
Resistance ⁽²⁾	Ω	3.2	3.6	12.8	16.9	50.5					

¹⁾ Nominal - ²⁾ $\pm 7\%$ at temperature 20°C [68°F]

	Voltage (V)	Connector type	Coil description	Marking	Coil Mat no.
=OB 01 =OB 02	12 DC	EN 175301-803 (Ex. DIN 43650)	C6501 12DC	12 DC	R933000100
=OB 03	12 DC	AMP JUNIOR	C6503 12DC	12 DC	R933000119
=OB 07	12 DC	DEUTSCH DT 04-2P	C6507 12DC	12 DC	R933000107
=OB 31	12 DC	Cable 350 mm long	C6531 12DC	12 DC	R933000104
=AD 01 =AD 02	13 DC	EN 175301-803 (Ex. DIN 43650)	C6501 13DC	13 DC	R933000101
=AD 07	13 DC	DEUTSCH DT 04-2P	C6507 13DC	13 DC	R933000112
=OC 01 =OC 02	24 DC	EN 175301-803 (Ex. DIN 43650)	C6501 24DC	24 DC	R933000102
=OC 03	24 DC	AMP JUNIOR	C6503 24DC	24 DC	R933000120
=OC 07	24 DC	DEUTSCH DT 04-2P	C6507 24DC	24 DC	R933000111
=OC 31	24 DC	Cable 350 mm long	C6531 24DC	24 DC	R933000110
=AC 01 =AC 02	27 DC	EN 175301-803 (Ex. DIN 43650)	C6501 27DC	27 DC	R933000103
=AC 03	27 DC	AMP JUNIOR	C6503 27DC	27 DC	R93307055
=AC 07	27 DC	DEUTSCH DT 04-2P	C6507 27DC	27 DC	R933000113
=OD 01 =OD 02	48 DC	EN 175301-803 (Ex. DIN 43650)	C6501 48DC	48 DC	R933000114

Characteristic curves

Measured with hydraulic fluid ISO-VG32 at $45^{\circ} \pm 5^{\circ} \text{ C}$ [$113^{\circ} \pm 9^{\circ} \text{ F}$]; ambient temperature 20° C [68° F].

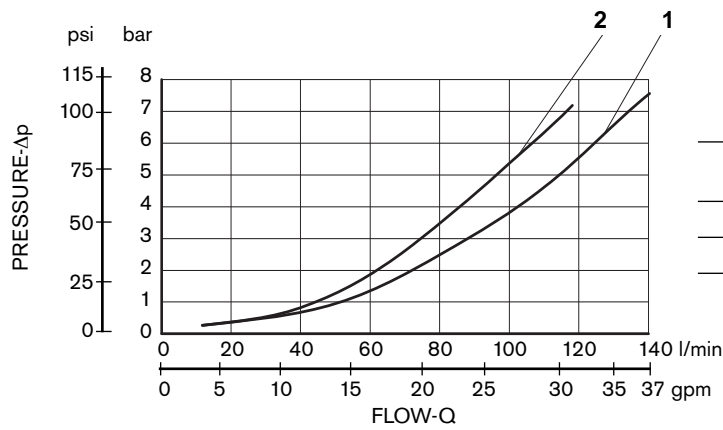

Scheme	Curve n.			
	P1>C1	P1>C2	P2>C4	P2>C3
VS311	2	2	2	2
VS312-VS315	1	1	1	1

Performances limits

The performance limits refer to the following conditions: coils at operating temperature, voltage supply 10% below nominal, no back pressure in the tank line.

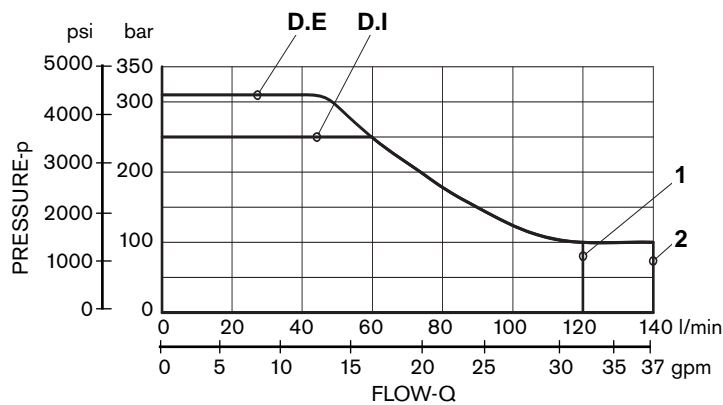
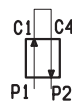

Scheme	Curve n.
VS311	1
VS312-VS315	2

Flow across both ways: forward across P1>C1 and reverse across C4>P2

External Dimensions and Fittings

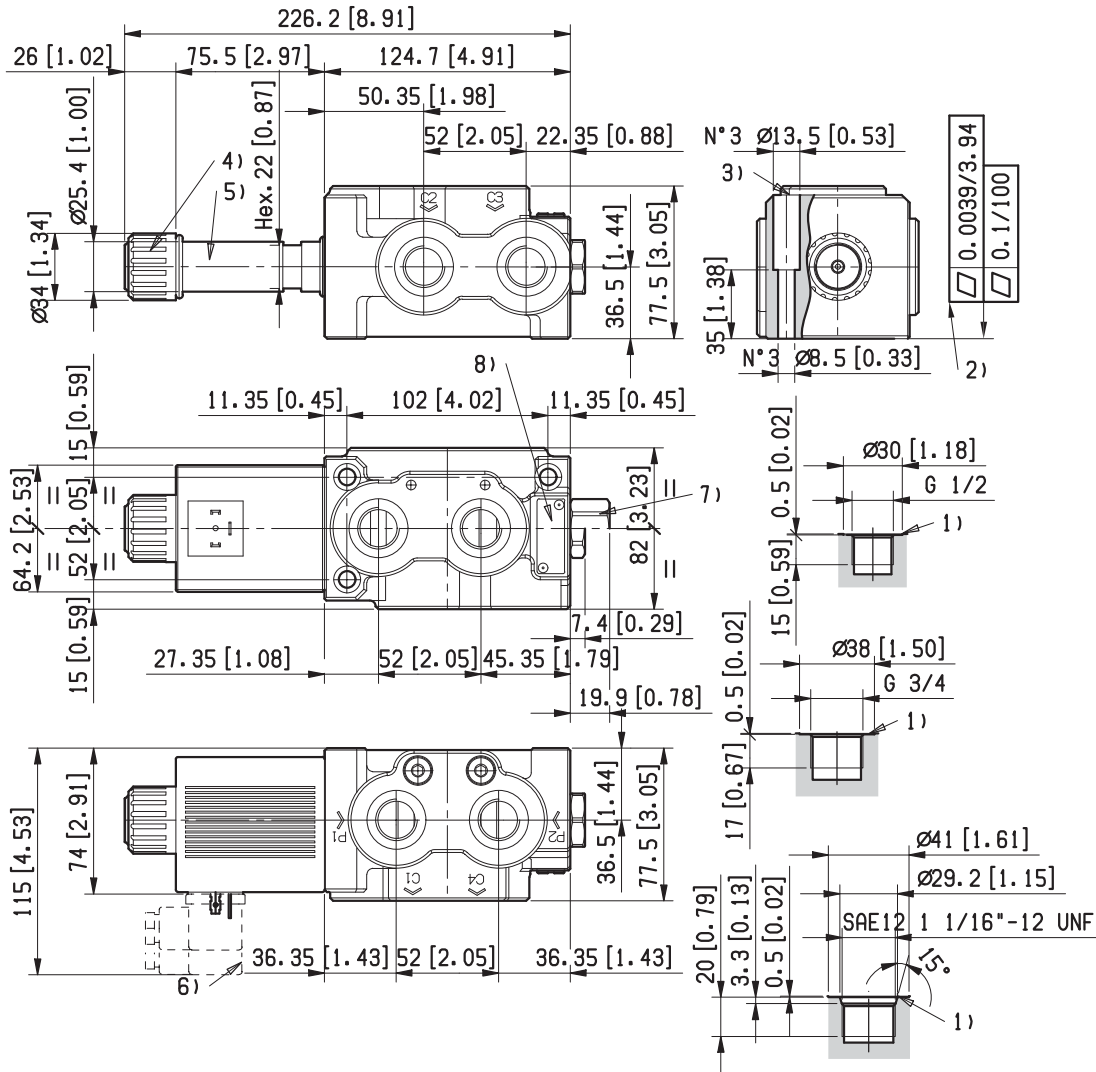

1 Ports P1, P2, C1, C2, C3, C4.

2 The mounting surface flatness must comply with specifications.

3 Two fixation screws M8x45 with strength class DIN 8.8.
Torque 15 – 16 Nm [11.1 – 11.8 ft-lb].

4 Ring nut for coil locking OD 34 mm [1.34 in].
Torque 7–8 Nm [5.2 – 5.9 ft-lb].

5 Solenoid tube hex 22 mm.

Torque 25 – 27 Nm [18.4 – 19.9 ft-lb].

6 Minimum clearance needed for connector removal.

7 External drain plug available with G 1/4 and SAE 4 port.
Hex. 27 mm. Torque 25 – 27 Nm [18.4 – 19.9 ft-lb].

8 Identification label.

External Dimensions and Fittings

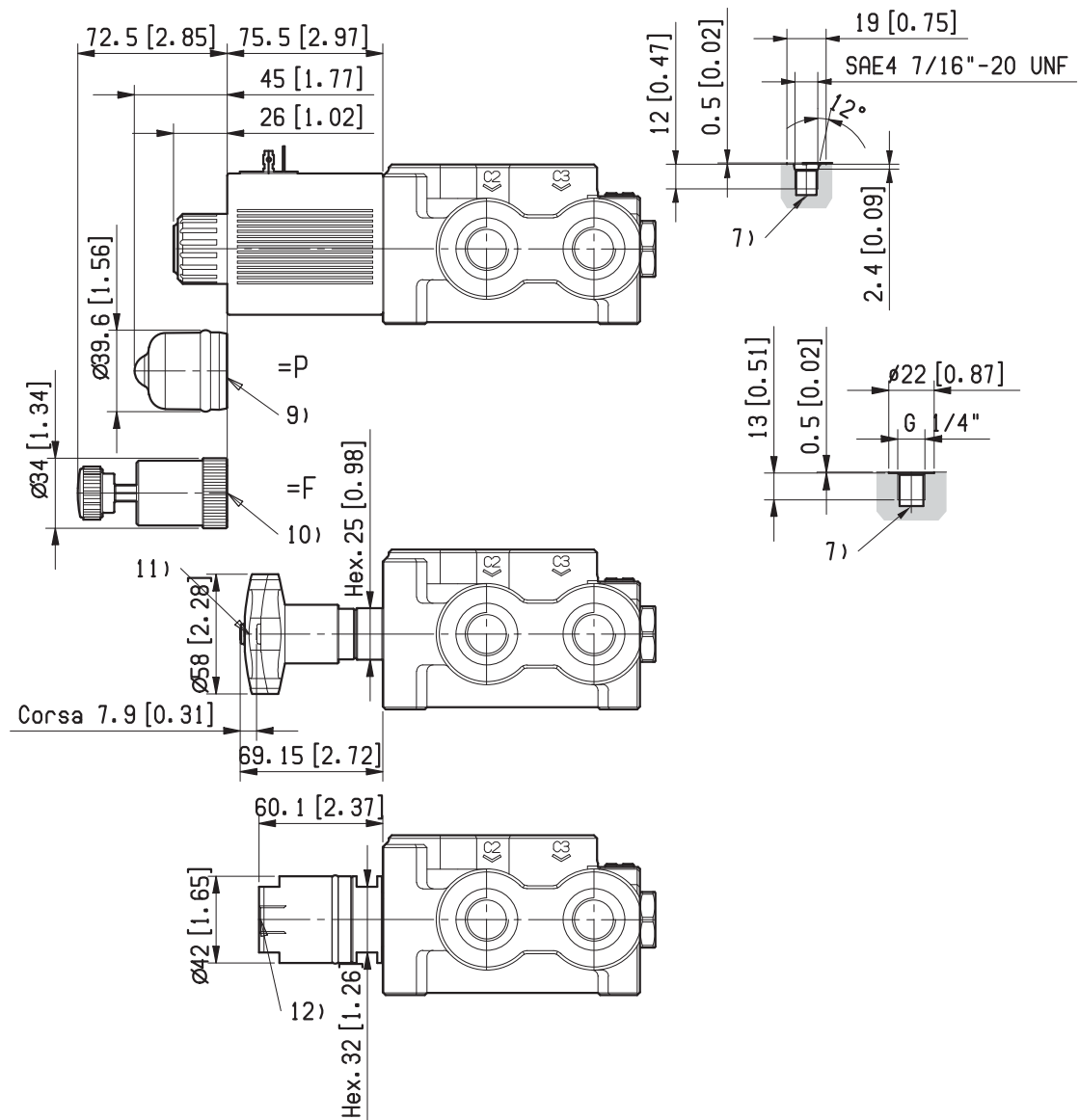

9 Optional push-button, P type, emergency for spool opening: it is pressure stuck to the ring nut for coil locking. Mat no. R933003424

10 Optional screw type emergency, F type, for spool opening: it is screwed (torque 8-9 Nm [5.9-6.6 ft-lb]) to the tube as replacement of the coil ring nut. Mat no. R933003713

11 Dimensions of optional manual version, push and twist type. Hex 25mm, torque 25 – 27 Nm [18.4 – 19.9 ft-lb].

12 Dimensions of optional hydraulic / pneumatic piloted version. Pilot port plug available with G 1/4: hex 32 mm, torque 25 – 27 Nm [18.4 – 19.9 ft-lb].

Electric connection

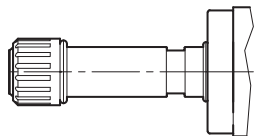
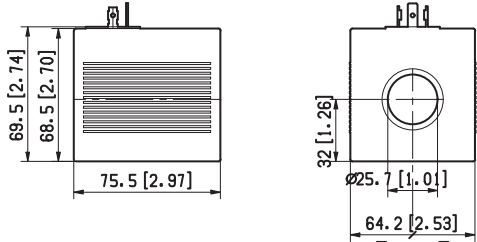
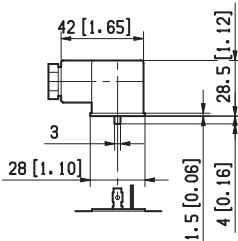
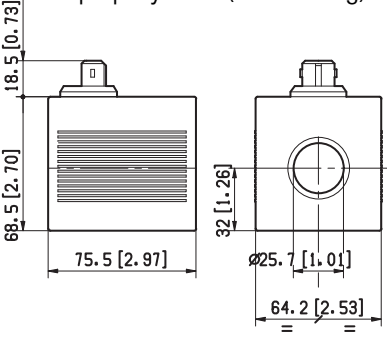
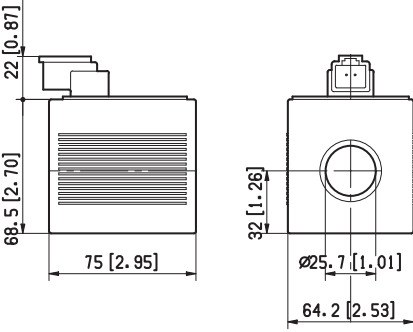
<p>=00</p>	<p>Without coils, but with ring nut and O-Rings for coil fitting (solution recommended for flexible stock handling)</p> 	<p>=01</p>	<p>With coils having plug-in pins EN 175301-803, without connectors</p> 																
<p>=02</p>	<p>With coils and with connectors non-assembled, type EN 175301-803. Protection class: IP 65 when connector with seal is properly screwed down, and cable clamp is correctly tightened. 182-09: Standard. 182-LED-T-A1: with LED monitoring presence of voltage. 182-09-G-DO-2-1: with VDR (Voltage Dependent Resistor), to prevent input voltage over-shootings.</p> <table border="1" data-bbox="161 831 699 1061"> <thead> <tr> <th>Mat. No.</th> <th>Description</th> </tr> </thead> <tbody> <tr> <td>R933002885</td> <td>182-09 GRAY</td> </tr> <tr> <td>R933002889</td> <td>182-09 BLACK</td> </tr> <tr> <td>R933002893</td> <td>182-LED-T-A1 12 DC</td> </tr> <tr> <td>R933002894</td> <td>182-LED-T-A1 24 DC</td> </tr> <tr> <td>R933002896</td> <td>182-LED-T-A1 48 DC</td> </tr> <tr> <td>R933002886</td> <td>182-09-G-DO-2-1 12DC with VDR</td> </tr> <tr> <td>R933002887</td> <td>182-09-G-DO-2-1 24DC with VDR</td> </tr> </tbody> </table> 			Mat. No.	Description	R933002885	182-09 GRAY	R933002889	182-09 BLACK	R933002893	182-LED-T-A1 12 DC	R933002894	182-LED-T-A1 24 DC	R933002896	182-LED-T-A1 48 DC	R933002886	182-09-G-DO-2-1 12DC with VDR	R933002887	182-09-G-DO-2-1 24DC with VDR
Mat. No.	Description																		
R933002885	182-09 GRAY																		
R933002889	182-09 BLACK																		
R933002893	182-LED-T-A1 12 DC																		
R933002894	182-LED-T-A1 24 DC																		
R933002896	182-LED-T-A1 48 DC																		
R933002886	182-09-G-DO-2-1 12DC with VDR																		
R933002887	182-09-G-DO-2-1 24DC with VDR																		
<p>=03</p>	<p>With coils having AMP Junior connector, and with bi-directional diode. Protection class: IP 65 with female connector properly fitted (see drawing).</p> 	<p>=07</p>	<p>With coils having DEUTSCH DT 04-2P connector, and with bi-directional diode. Protection class: IP 69 K with female connector properly fitted (see drawing).</p> 																
<p>=31</p>	<p>With coils having bi-directional diode and bipolar sheathed free lead, 350 mm long, without pins.</p> 