

Relief, direct acting guided
poppet type
Special cavity, 009

VS-80

04.11.05 - X - 99 - Z

RE 18318-25

Edition: 01.2019

Replaces: 07.2018



Description

Flow is blocked from 1 to 2 until pressure increases to meet the selected valve setting, lifting the poppet from its seat and allowing relief flow through 2 to tank. Pressure at 2 is additive to the relief setting of the valve. The unique Bosch Rexroth Oil Control poppet design provides enhanced stability at all flows and pressures.

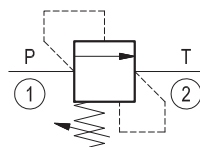
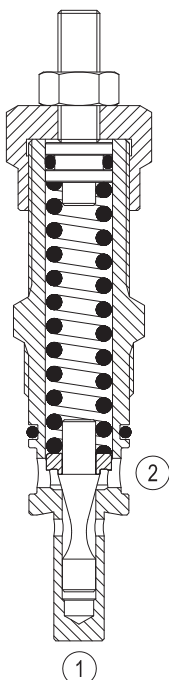

Technical data

Max. operating pressure port 1 (P)	350 bar (5000 psi)
Max. pressure admitted port 2 (T)	140 bar (2000 psi)
Max. flow	80 l/min (21 gpm)
Max. internal leakage ¹⁾	15 drops/min.
Fluid temperature range	-30 to 100 °C (-22 to 212 °F)
Installation torque	83 - 92 Nm (61 - 68 ft-lbs)
Weight	0.35 kg (0.77 lbs)
MTTFD	150 years see RE 18350-51
Special cavity	009 (see data sheet 18325-75)
Lines bodies and standard assemblies	Please refer to section "Hydraulic integrated circuit" or consult factory
Seal kit ²⁾	Code: RG0009010000100 material no: R930001694
Fluids	Mineral-based or synthetics with lubricating properties at viscosities of 10 to 500 mm ² /s (cSt)
Recommended degree of fluid contamination	Nominal value max. 10µm (NAS 8) / ISO 4406 20/18/15
Installation position	No restrictions
Other Technical Data	See data sheet 18350-50

1) At 80% of pressure setting

2) Only external seals for 10 valves

Characteristic curve

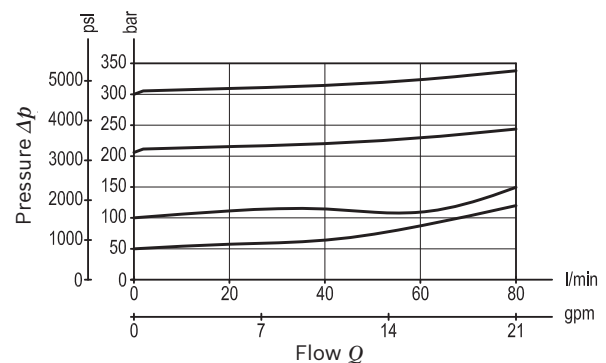

Ordering code

04.11.05	X	99	Z	00	*
-----------------	----------	-----------	----------	-----------	----------

Relief, direct acting guided poppet type

Adjustments

- 03** Leakproof hex. socket screw
- 04** Handknob and locknut

99 Special cavity, 009

Series O/A to L
unchanged performances and dimensions

Version and options standard

SPRINGS			
	Adj. press. range bar (psi)	Pressure increase bar/turn (psi/turn)	Std. setting bar (psi) Q=5 l/min
05	* 5-50 (75-725)	6 (87)	50 (725)
10	30-100 (435-1450)	12 (174)	100 (1450)
20	80-250 (1160-3600)	27 (392)	200 (2900)
35	140-350 (2000-5000)	62 (899)	350 (5000)

Note: Special settings available. Contact factory authorized representative for ordering code.

* minimum pressure setting intended with Q=5 l/min

Preferred types

Type	Material number
041105039905000	R930000117
041105039910000	R930000119
041105039920000	R901113620
041105049910000	R930000121

Type	Material number
041105049920000	R930000122
041105039935000	R930008396

Dimensions

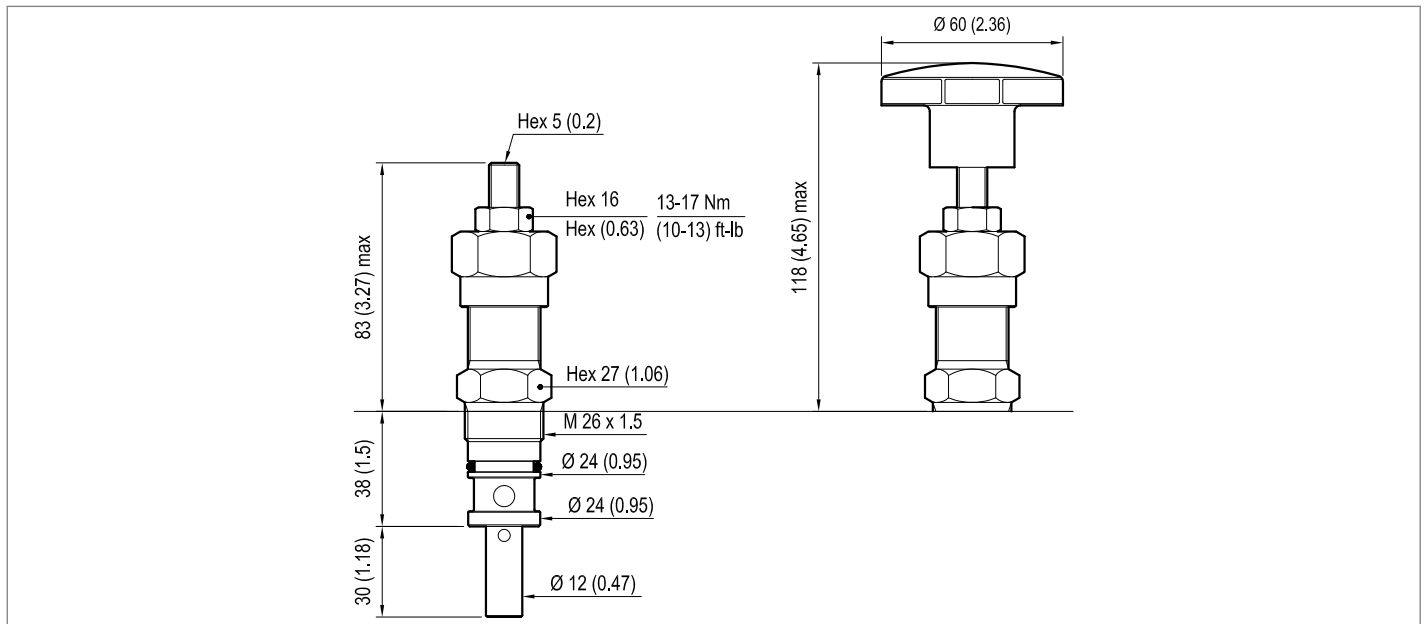

Bosch Rexroth Oil Control S.p.A.

Via Leonardo da Vinci 5
P.O. Box no. 5
41015 Nonantola – Modena, Italy
Tel. +39 059 887 611
Fax +39 059 547 848
compact-hydraulics-cv@boschrexroth.com
www.boschrexroth.com/compacthydraulics

© This document, as well as the data, specifications and other information set forth in it, are the exclusive property of Bosch Rexroth Oil Control S.p.a.. It may not be reproduced or given to third parties without its consent. The data specified above only serve to describe the product. No statements concerning a certain condition or suitability for a certain application can be derived from our information. The information given does not release the user from the obligation of own judgment and verification. It must be remembered that our products are subject to a natural process of wear and aging. Subject to change.