

Solenoid operated valves direct acting spool 3-way 2-position

Common cavity, Size 10

VED-10A-32

OD.13 - X - 77 - Y - 00

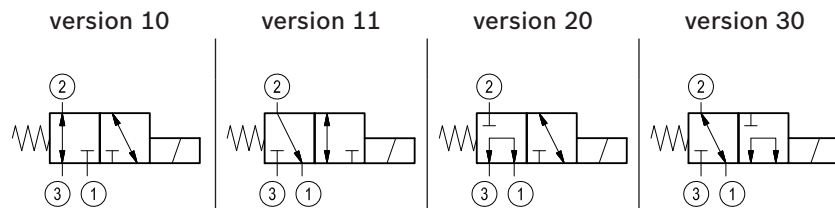
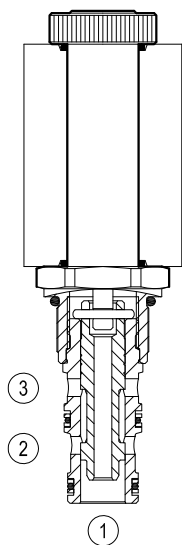
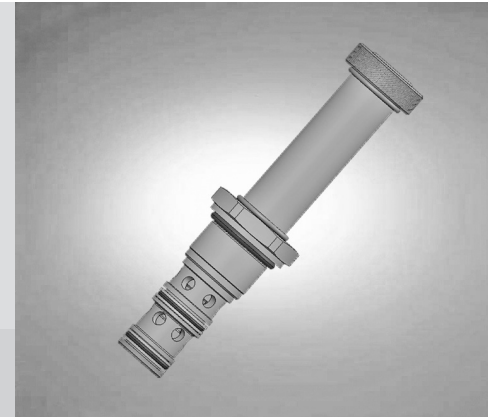

General

Weight	kg (lbs)	0.22 (0.49)
Installation orientation		Optional
Ambient temperature range	°C (°F)	-30 to 60 (-22 to 140) - coil 30W

Hydraulic

Max. operating pressure port 2-3	bar (psi)	280 (4000)
Max. operating pressure port 1	bar (psi)	210 (3000)
Max. flow	l/min. (gpm)	20 (6)
Max. internal leakage (*)	cm ³ /min. (cu.in./min.)	80 (5)
Fluid temperature range	°C (°F)	-20 to 80 (-4 to 176)
Fluids		Mineral-based or synthetics with lubricating properties at viscosities of 20 to 380 mm ² /s (cSt)
Installation torque	Nm (ft-lbs)	44-56 (33-41)
Filtration		Nominal value max. 10µm (NAS 8) ISO 4406 19/17/14
Cavity		CA-10A-3N see RE 18325-70
Seal kit	code material no.	RG10A3010530100 R930000990
Seal kit coil	code material no.	RG16A1PMVQ0010 R934003962
Other technical data		See data sheet RE 18350-50

(*) Measured at 210 bar (3000 psi) (oil at 46 cSt)

Electrical

Type of voltage		DC voltage
Coil type		S7
Supply voltage		See data sheet RE 18325-90
Power consumption	W	30
Duty cycle coil	%	100 see RE 18325-90
Type of protection		See data sheet RE 18325-90
Nominal voltage coil 30W		-10% + 10%

Note: Coils must be ordered separately.

Dimensions

Solenoid operated valve, spool 3-way 2-position

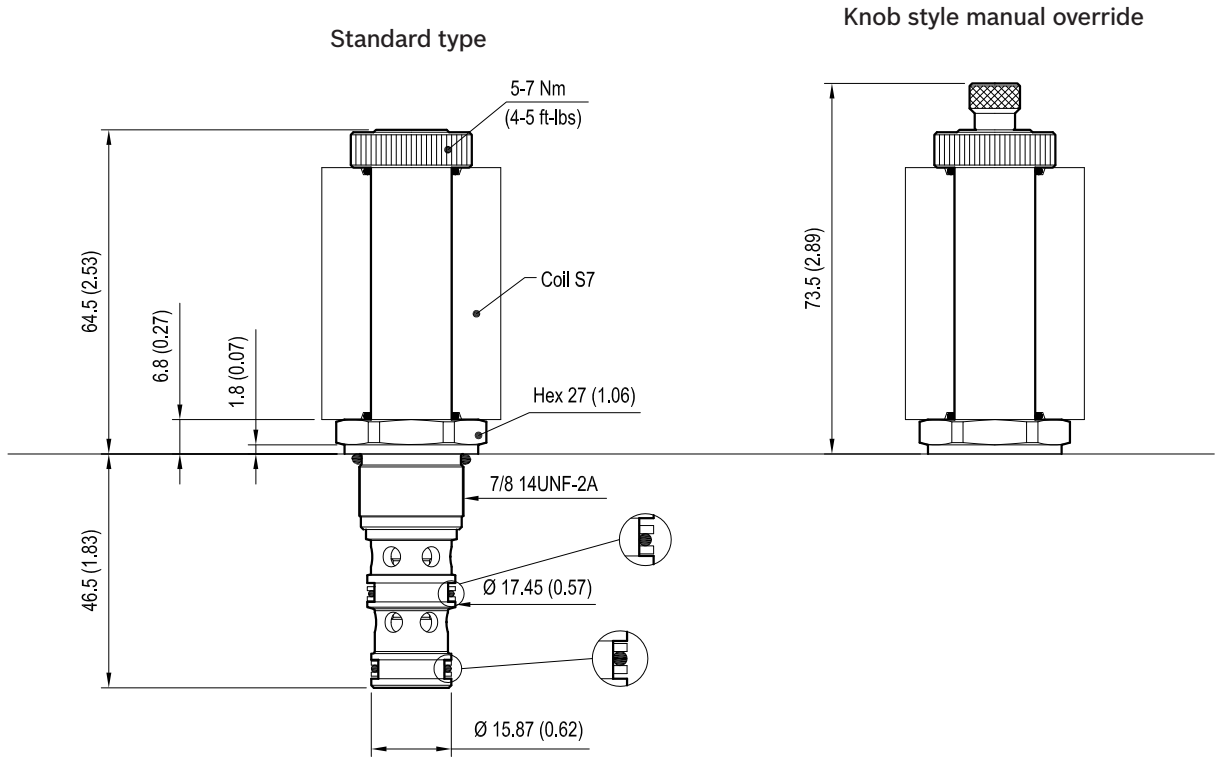

(only version 11)

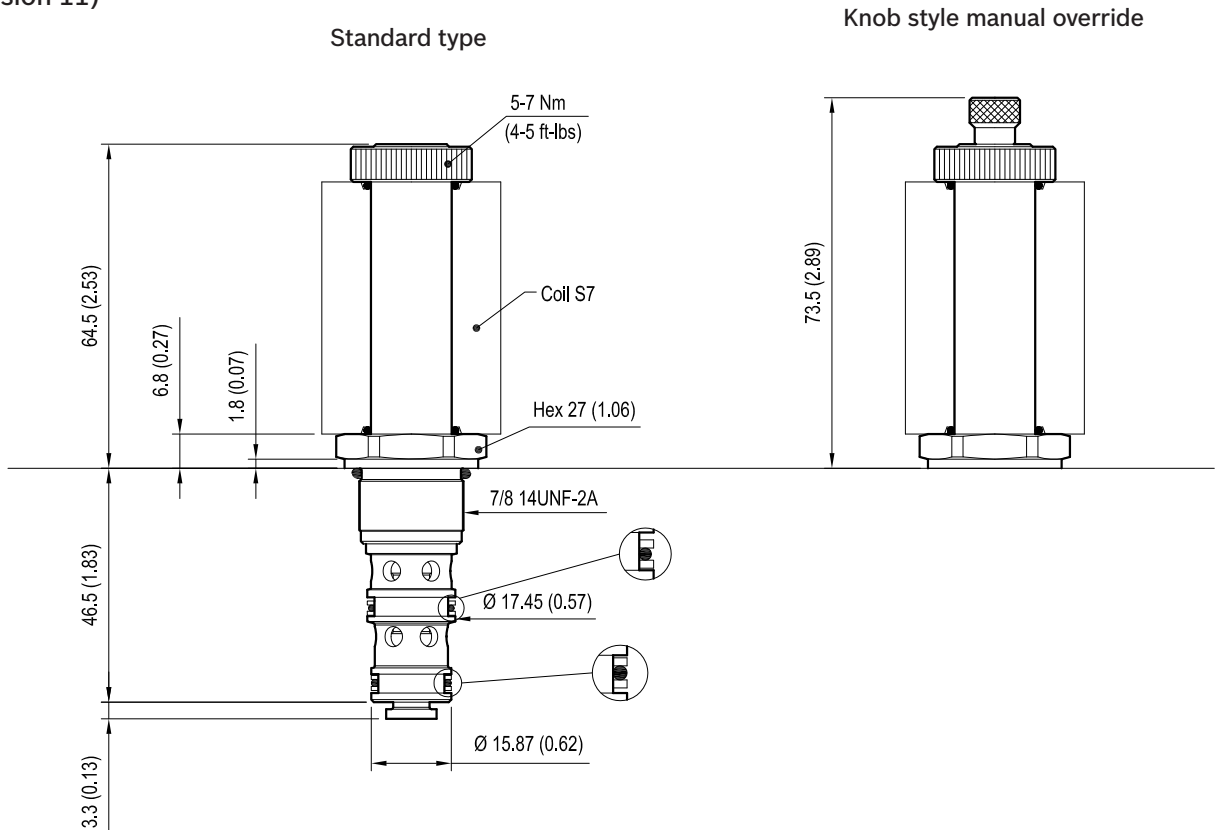

mm (Inches)

Performance graphs

Performance limits
(Hot coil at nominal voltage)

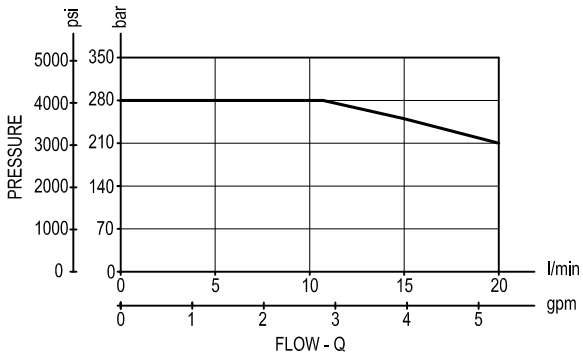

Version 10

Characteristic curves

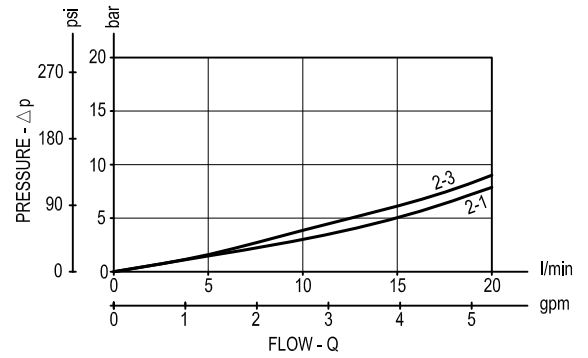

Version 11

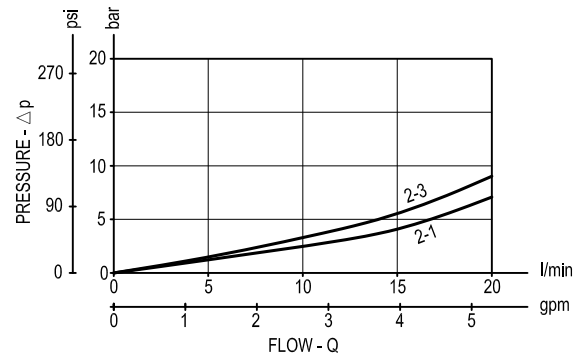
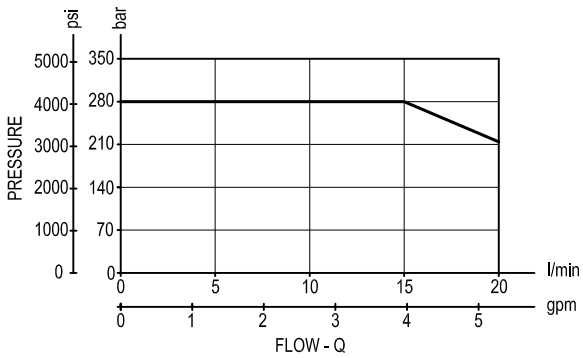

Version 20

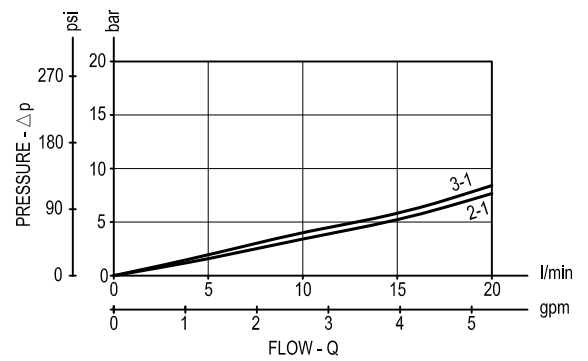
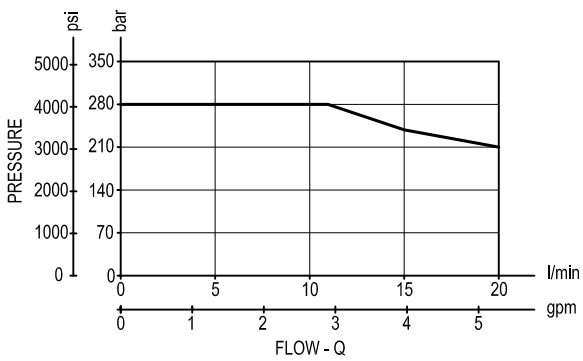

Version 30

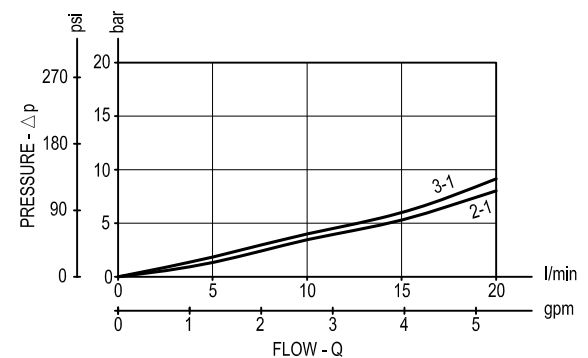
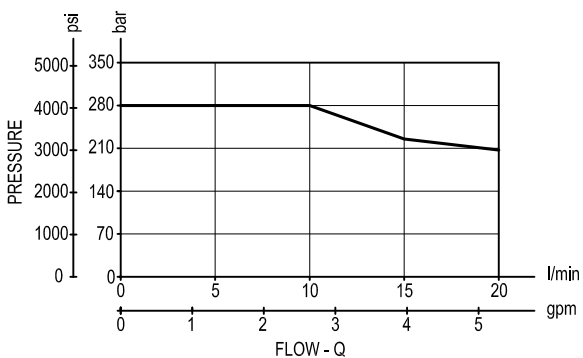

Ordering code

OD.13	*	77	*	00
-------	---	----	---	----

Solenoid operated valves
spool 4-way 2 position

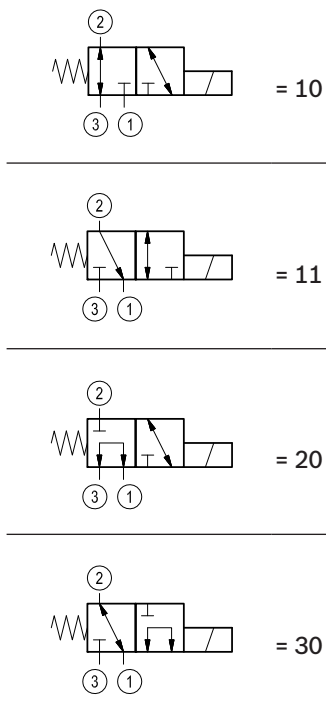

standard type

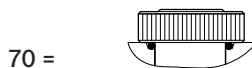

Knob style manual override

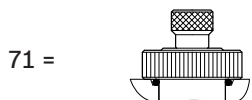

Common cavity: CA-10A-3N

Type	Material number
OD131077700000	R901113686
OD131077710000	R901113687
OD131177700000	R901125116
OD131177710000	R901126890
OD132077700000	R901113690
OD132077710000	R901113692
OD133077700000	R901115704
OD133077710000	R901126898

Type	Material number